

harman/kardon

AVR154

5 X 30W 5.1 CHANNEL A/V RECEIVER

SERVICE MANUAL



CONTENTS

ESD WARNING.....	2	DISASSEMBLY.....	31
LEAKAGE TESTING.....	3	UNIT EXPLODED VIEW.....	32
BASIC SPECIFICATIONS.....	4	EXPLODED VIEW PARTS LIST.....	33
PACKAGING.....	5	AMP BIAS ADJUSTMENT.....	34
FRONT PANEL CONTROLS.....	6	BLOCK DIAGRAM.....	35
REAR PANEL CONNECTIONS.....	8	PCB DRAWINGS.....	36
REMOTE CONTROL FUNCTIONS.....	10	ELECTRICAL PARTS LIST.....	42
CONNECTIONS/INSTALLATION.....	13	SEMICONDUCTOR PINOUTS.....	71
OPERATION.....	24	SCHEMATICS.....	132
TROUBLESHOOTING GUIDE.....	29	WIRING DIAGRAM.....	140
REMOTE & PROCESSOR RESETS.....	30		

harman/kardon, Inc.
250 Crossways Park Dr.
Woodbury, New York 11797

Released 2008
Discontinued XXXX

Rev0 5/2008

ELECTROSTATICALLY SENSITIVE (ES) DEVICES

Some semiconductor (solid state) devices can be damaged easily by static electricity. Such components commonly are called Electrostatically Sensitive (ES) Devices. Examples of typical ES devices are integrated circuits and some field effect transistors and semiconductor "chip" components.

The following techniques should be used to help reduce the incidence of component damage caused by static electricity.



1. Immediately before handling any semiconductor component or semiconductor-equipped assembly, drain off any electrostatic charge on your body by touching a known earth ground. Alternatively, obtain and wear a commercially available discharging wrist strap device, which should be removed for potential shock reasons prior to applying power to the unit under test.
2. After removing an electrical assembly equipped with ES devices, place the assembly on a conductive surface such as aluminum foil, to prevent electrostatic charge build-up or exposure of the assembly.
3. Use only a grounded-tip soldering iron to solder or unsolder ES devices.
4. Use only an anti-static solder removal device. Some solder removal devices not classified as "anti-static" can generate electrical charges sufficient to damage ES devices.
5. Do not use freon-propelled chemicals. These can generate electrical charge sufficient to damage ES devices.
6. Do not remove a replacement ES device from its protective package until immediately before you are ready to install it. (Most replacement ES devices are packaged with leads electrically shorted together by conductive foam, aluminum foil or comparable conductive material.)
7. Immediately before removing the protective material from the leads of a replacement ES device, touch the protective material to the chassis or circuit assembly into which the device will be installed.

CAUTION : Be sure no power is applied to the chassis or circuit, and observe all other safety precautions.

8. Minimize bodily motions when handling unpackaged replacement ES devices. (Otherwise harmless motion such as the brushing together of your clothes fabric or the lifting of your foot from a carpeted floor can generate static electricity sufficient to damage an ES devices.

PRODUCT SAFETY NOTICE

Each precaution in this manual should be followed during servicing.

Components identified with the IEC symbol  in the parts list are special significance to safety. When replacing a component identified with , use only the replacement parts designated, or parts with the same ratings or resistance, wattage, or voltage that are designated in the parts list in this manual. Leakage-current or resistance measurements must be made to determine that exposed parts are acceptably insulated from the supply circuit before returning the product to the customer.

SAFETY PRECAUTIONS

The following check should be performed for the continued protection of the customer and service technician.

LEAKAGE CURRENT CHECK

Measure leakage current to a known earth ground (water pipe, conduit, etc.) by connecting a leakage current tester between the earth ground and all exposed metal parts of the appliance (input/output terminals, screwheads, metal overlays, control shaft, etc.). Plug the AC line cord of the appliance directly into a 120V AC 60Hz outlet and turn the AC power switch on. Any current measured must not exceed 0.5mA.

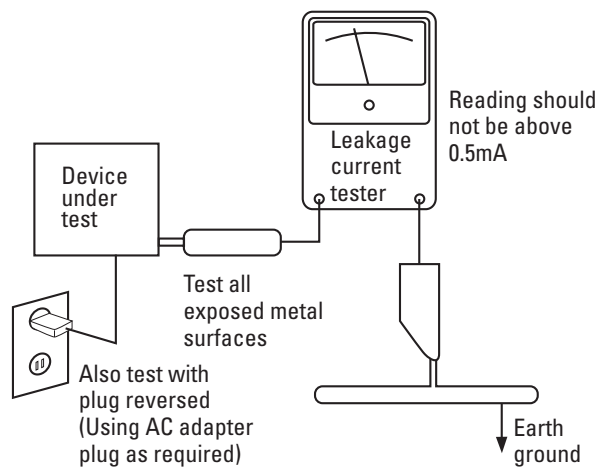

AC Leakage Test

ANY MEASUREMENTS NOT WITHIN THE LIMITS OUTLINED ABOVE ARE INDICATIVE OF A POTENTIAL SHOCK HAZARD AND MUST BE CORRECTED BEFORE RETURNING THE APPLIANCE TO THE CUSTOMER.

AVR 154 TECHNICAL SPECIFICATIONS

Audio Section

Stereo Mode	
Continuous Average Power (FTC)	
40 Watts per channel, 20Hz–20kHz, @ <0.07% THD, both channels driven into 8 ohms	
Five-Channel Surround Modes	
Power per Individual Channel	
Front L&R channels:	
30 Watts per channel @ <0.07% THD, 20Hz–20kHz into 8 ohms	
Center channel:	
30 Watts @ <0.07% THD, 20Hz–20kHz into 8 ohms	
Surround (L & R Side) channels:	
30 Watts per channel @ <0.07% THD, 20Hz–20kHz into 8 ohms	
Input Sensitivity/Impedance	
Linear (High-Level)	200mV/47k ohms
Signal-to-Noise Ratio (IHF-A)	100dB
Surround System Adjacent Channel Separation	
Pro Logic I/II	40dB
Dolby Digital (AC-3)	55dB
DTS	55dB
Frequency Response	
@ 1W (+0dB, –3dB)	10Hz – 130kHz
High Instantaneous	
Current Capability (HCC)	±25 Amps
Transient Intermodulation	
Distortion (TIM)	Unmeasurable
Slew Rate	40V/μsec

FM Tuner Section

Frequency Range	87.5–108.0MHz
Usable Sensitivity	IHF 1.3μV/13.2dBf
Signal-to-Noise Ratio	Mono/Stereo 70/68dB
Distortion	Mono/Stereo 0.2/0.3%
Stereo Separation	40dB @ 1kHz
Selectivity	±400kHz, 70dB
Image Rejection	80dB
IF Rejection	90dB

AM Tuner Section

Frequency Range	520–1720kHz
Signal-to-Noise Ratio	45dB
Usable Sensitivity	Loop 500μV
Distortion	1kHz, 50% Mod 0.8%
Selectivity	±10kHz, 30dB

Video Section

Television Format	NTSC
Input Level/Impedance	1Vp-p/75 ohms
Output Level/Impedance	1Vp-p/75 ohms
Video Frequency Response (Composite and S-Video)	10Hz–8MHz (–3dB)
Video Frequency Response (Component Video)	10Hz–100MHz (–3dB)
HDMI	Switching

General

Power Requirement	AC 120V/60Hz
Power Consumption	65W idle, 540W maximum (5 channels driven)
Dimensions	(Product) (Shipping)
Width	17-5/16 inches (440mm) 22 inches (559mm)
Height	6-1/2 inches (165mm) 10-1/2 inches (267mm)
Depth	15 inches (382mm) 18-3/4 inches (476mm)
Weight	(Product) (Shipping)
	20.5 lb (9.3kg) 25.3 lb (11.5kg)

Depth measurement includes knobs, buttons and terminal connections.

Height measurement includes feet and chassis.

All features and specifications are subject to change without notice.

Harman Kardon and Logic 7 are trademarks of Harman International Industries, Incorporated, registered in the United States and/or other countries. Designed to Entertain is a trademark of Harman International Industries, Incorporated.

Blu-ray Disc is a trademark of the Blu-ray Disc Association.

Cirrus Logic is a registered trademark of Cirrus Logic, Inc.

Dolby, Pro Logic and the double-D symbol are trademarks of Dolby Laboratories. Manufactured under license from Dolby Laboratories.

Manufactured under license under U.S. Patent #'s: 5,451,942; 5,956,674; 5,974,380; 5,978,762; 6,487,535; 7,003,467 & other U.S. and worldwide patents issued & pending. DTS, DTS Digital Surround, ES, and Neo:6 are registered trademarks and the DTS logos and Symbol are trademarks of DTS, Inc. © 1996-2007 DTS, Inc. All rights reserved.

HD-DVD is a trademark of the DVD Format/Logo Licensing Corporation (DVD FLLC).

HDMI is a trademark or registered trademark of HDMI Licensing LLC.

iPod is a trademark of Apple Inc., registered in the U.S. and other countries.

SACD is a trademark of Sony Corporation.

TiVo is a registered trademark of TiVo Inc.

Please register your AVR 154 on our Web site at www.harmankardon.com. Note: You'll need the product's serial number. At the same time, you can choose to be notified about our new products and/or special promotions.

1. Instruction manual ass'y - Accessories

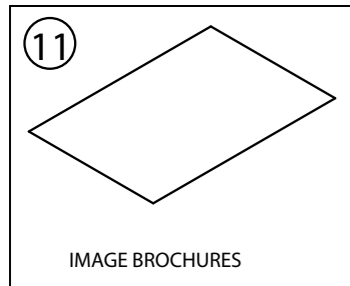
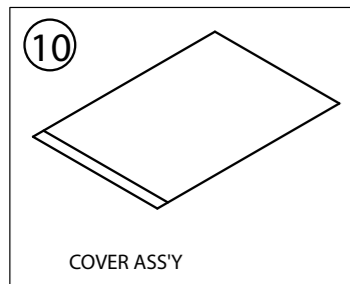
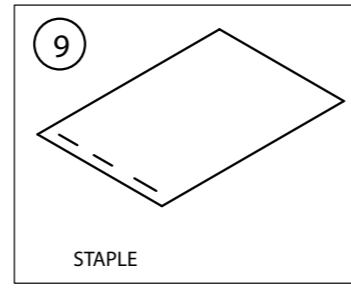
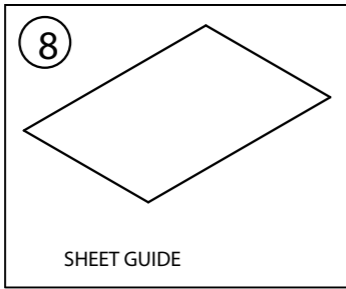
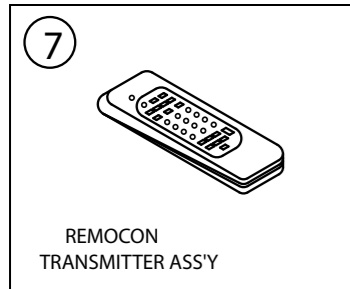
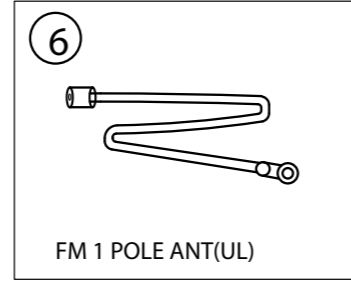
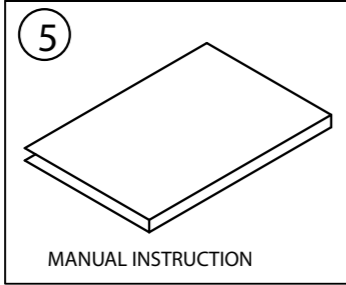
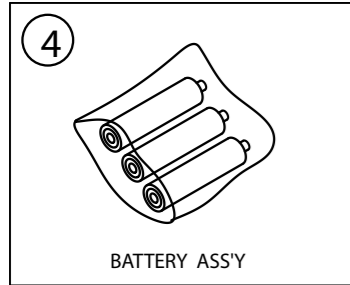
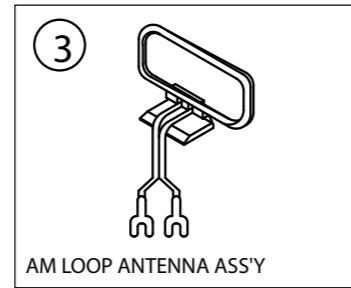
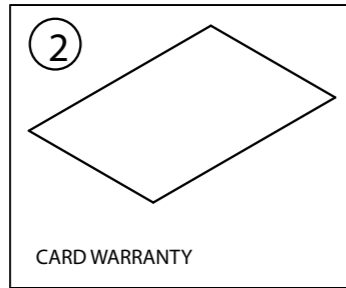
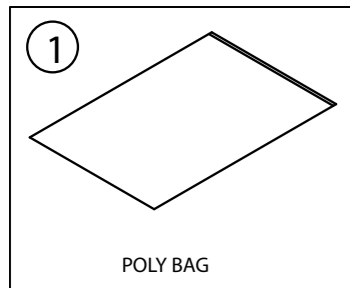

NO	DESCRIPTION	PARTS NO.	Q,ty
1	POLY BAG		1
2	CARD WARRANTY	CQE1A172X	1
3	AM LOOP ANTENNA	CSA1A020Z	1
4	BATTERY		3
5	INSTRUCTION MANUAL	visit www.harmankardon.com	1
6	FM 1 POL ANT(UL)	CSA1A019Z	1
7	REMOCON TRANSMITTER ASS'Y	CARTAVR154	1
8	SHEET GUIDE(QUIK START GUIDE)	CQE1A379Z	1
9	STAPLE		3
10	COVER ASS'Y	CGRAVR154ZA	1
	1 COVER A	CGR1A331H63	1
	2 COVER B	CGR1A332H63	1
	3 SHEET,FRONT COVER	CQE1A219Z	1
	4 PAD, COVER	CPS1A676	1
	5 BAG,POLY		1
11	IMAGE BROCHURES		1

2. Package Drawing

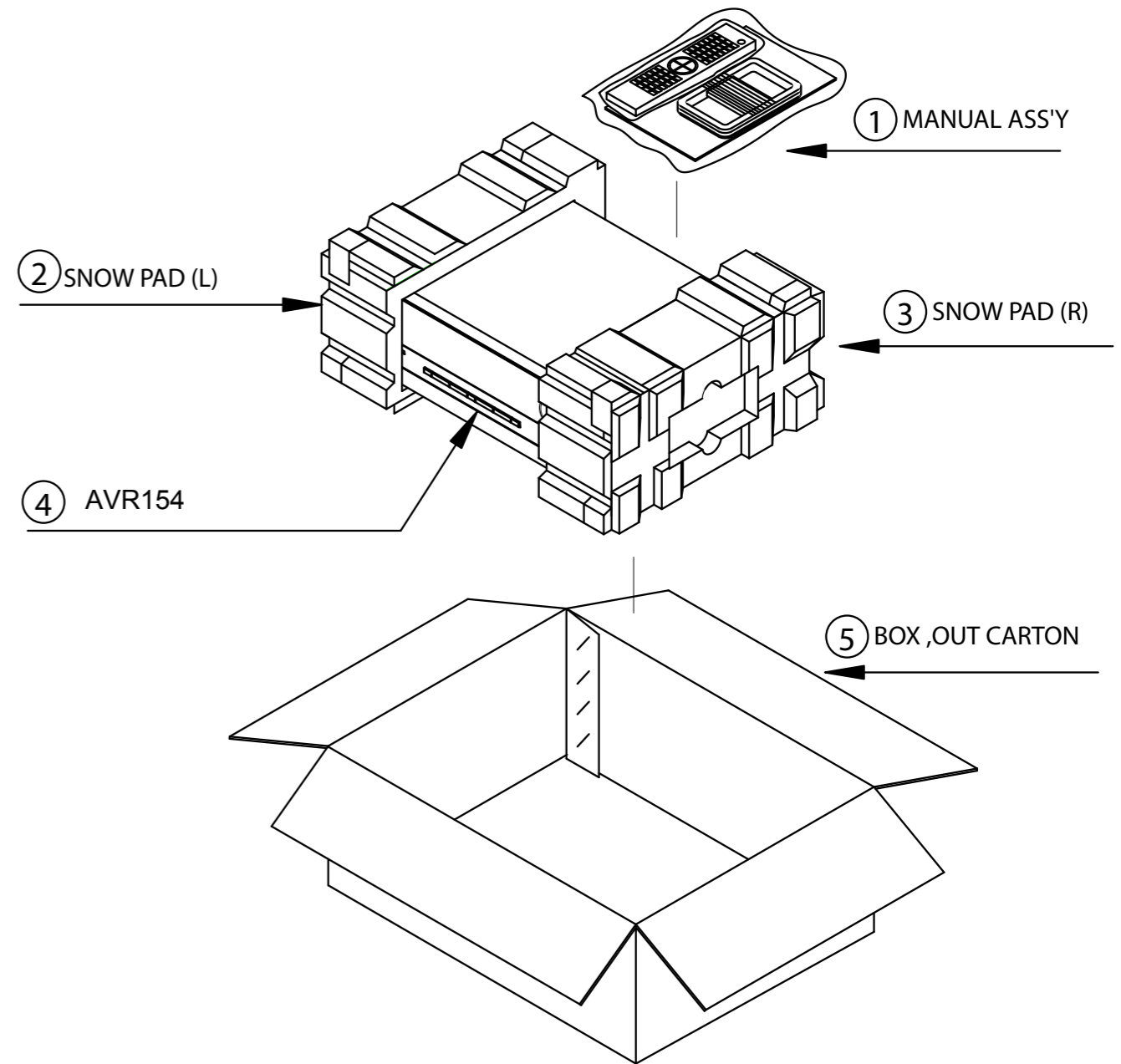

NO	DESCRIPTION	PARTS NO.	Q,ty
1	MANUAL ASS'Y		1
2	SNOW,PAD(L)	CPS5A564	1
3	SNOW,PAD(R)	CPS5A565	1
4	AVR154	AVR 154	1
5	BOX,OUT CARTON	CPG1A854Z	1

FRONT-PANEL CONTROLS

Main Power Switch: This mechanical switch turns the power supply on or off. It is usually left pressed in (On position), and cannot be turned on using the remote control.

Standby/On Switch: This electrical switch turns the receiver on for playback, or leaves it in Standby mode for quick turn-on using this switch or the remote control.

Power Indicator: This LED has four possible modes:

- **Main Power Off:** When the AVR is unplugged or the Main Power Switch is off, this LED remains unlit.
- **Standby:** This LED turns amber, indicating that the AVR is ready to be turned on.
- **On:** This LED turns white, and the AVR operates normally.
- **Protect:** If this LED ever turns red, turn off the AVR and unplug it. Check all speaker wires for a possible short. If none is found, bring the unit to an authorized Harman Kardon service center for inspection and repair before using it again.

When the main power is turned off, the LED is dark and the receiver won't respond to any button presses. When the main power is turned on, but before the Standby/On Switch is used, the LED turns amber to indicate that the receiver is in standby mode and is ready to be turned on. When the receiver is turned on, the LED turns white.

Source Select: Press this button to select a source device, which is a component where a playback signal originates, e.g., DVD, CD, cable TV, satellite or HDTV tuner. The source's name will appear in the Message Display.

Volume Knob: Turn this knob to raise or lower the volume, which will be shown in decibels (dB) in the Message Display.

Message Display: Various messages appear in this two-line display in response to commands and changes in the incoming signal. In normal operation, the current source name and the analog or digital audio input assigned to it appear on the upper line, while the surround mode is displayed on the lower line. When the on-screen display menu system (OSD) is in use, the message OSD ON will appear to remind you to check the video display.

Tuner Band: Press this button to select the tuner as the source, or to switch between the AM and FM bands.

Tuning: Press either side of this button to tune a radio station.

Tuning Mode: This button toggles between manual (one frequency step at a time) and automatic (seeks frequencies with acceptable signal strength) tuning mode. It also toggles between stereo and mono modes when an FM station is tuned.

Preset Stations: Press this button to select a preset radio station.

Headphone Jack: Plug a 1/4" headphone plug into this jack for private listening.

Surround Mode: Press this button to select a surround sound (e.g., multichannel) mode group. Choose from the Dolby modes, DTS modes, Logic 7 modes, DSP modes or Stereo modes.

Surround Select: After you have selected the desired surround mode group, press this button to select a specific mode.

Analog Audio, Video and Digital Audio Inputs: Connect a source component that will only be used temporarily, such as a camera or game console to these jacks. Use only one type of audio and one type of video connection.

Speaker/Channel Input Indicators: The box icons indicate which speaker positions you have configured (see the Initial Setup section), and the size (frequency range) of each speaker. When a digital audio input is used, letters will light inside the boxes to indicate which channels are present in the incoming signal.

Remote IR Sensor: This sensor receives infrared (IR) commands from the remote control. It is important to ensure that it is not blocked. If covering the sensor is unavoidable, such as when the AVR 154 is placed inside a cabinet, you may use an optional Harman Kardon HE 1000, or other infrared receiver, with an IR emitter ("blaster") placed directly over this sensor.

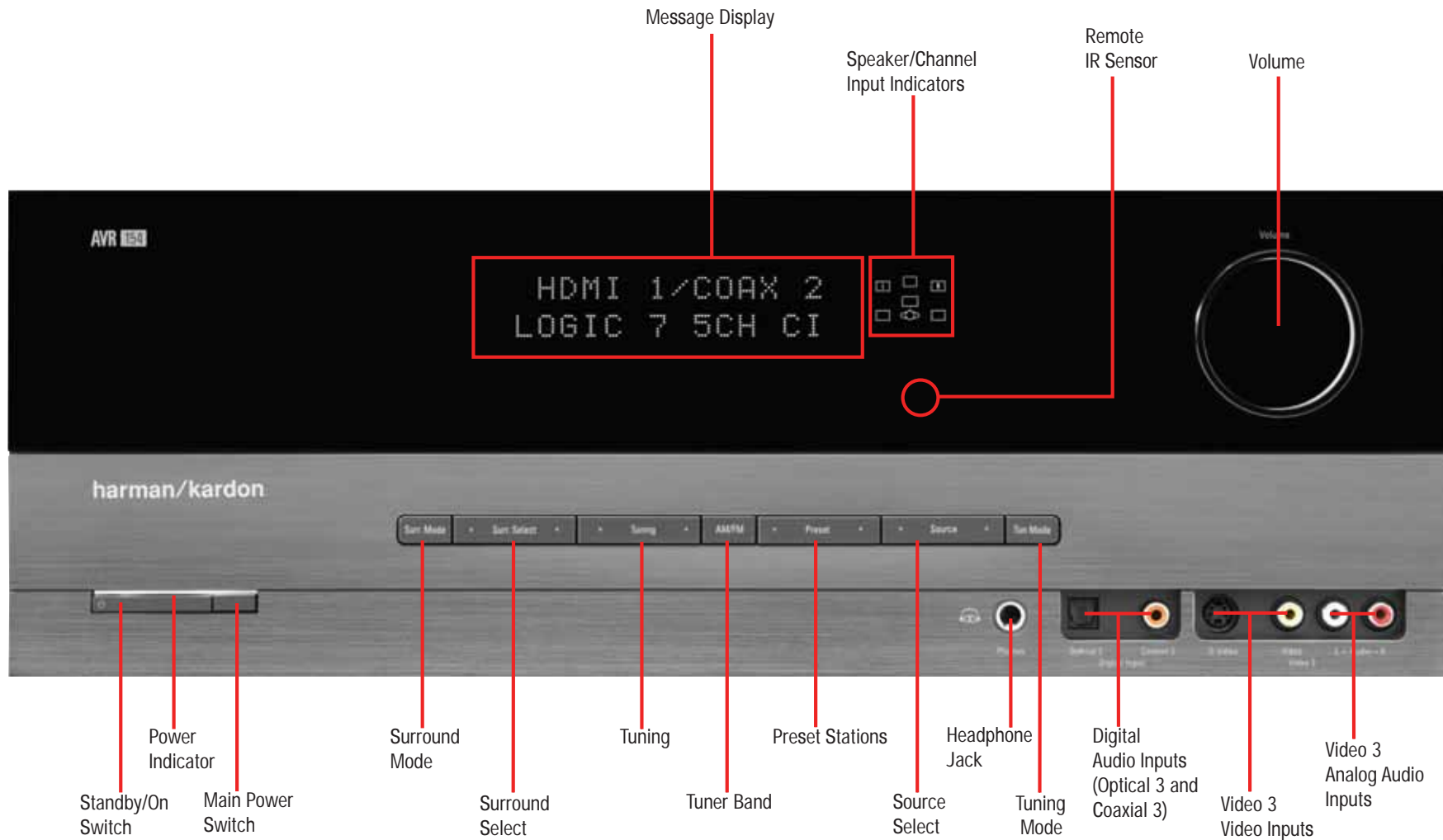

NOTE: To make it easier to follow the instructions throughout the manual that refer to this illustration, a copy of this page may be downloaded from the Product Support section at www.harmankardon.com.

REAR-PANEL CONNECTIONS

AM and FM Antenna Terminals: Connect the included AM and FM antennas to their respective terminals for radio reception.

Front, Center and Surround Speaker Outputs: Use two-conductor speaker wire to connect each set of terminals to the correct speaker. Remember to observe the correct polarity (positive and negative connections). Always connect the positive lead to the colored terminal on the receiver and the red terminal on the speaker. Connect the negative lead to the black terminal on both the receiver and the speaker. See the Connections section for more information on connecting your speakers.

Subwoofer Output: If you have a powered subwoofer with a line-level input, connect it to this jack.

Video 1, Video 2 and DVD Audio/Video Inputs: These jacks may be used to connect your video-capable source components (e.g., VCR, DVD player, cable TV box) to the receiver.

NOTE: If a source is HDMI-capable, it is preferable to connect it to one of the AVR's HDMI Inputs. If HDMI is not available on the source, then select one of the following types of video connection for each source device, in order of preference: component video, S-video or composite video.

See the Connections section for more information on audio and video connection options.

Video 1 Audio/Video Outputs: These jacks may be used to connect your VCR or another recorder.

Composite and S-Video Monitor Outputs: If any of your sources use composite or S-video connections, connect one or both of these monitor outputs to the corresponding inputs on your television or video display.

CD and Tape Audio Inputs: These jacks may be used to connect audio-only source components (e.g., CD player, tape deck). Do not connect a turntable to these jacks unless you are using it with a phono preamp.

Tape Outputs: These jacks may be used to connect a CDR or another audio-only recorder.

Coaxial and Optical Digital Audio Inputs: If your source has a compatible digital audio output, connect it to one of these jacks for improved audio performance. Use only one type of digital audio connection for each source.

Coaxial Digital Audio Output: If a source is also a digital audio recorder, connect the coaxial digital audio output to the recorder's coaxial digital input.

AUX Input: Enjoy audio from an iPod (not included), CD player or other portable player by connecting its headphone jack to this input using a 1/8" stereo mini-plug cable (not included). Video and still-image playback are not available at this input.

6-Channel Analog Audio Inputs: Connect the multichannel analog audio outputs of a DVD-Audio, SACD™, Blu-ray Disc™ or HD-DVD™ player (or any other external decoder) to these jacks.

Component Video Inputs: If both your video source (e.g., DVD player or HDTV tuner) and your television or video display have analog component video (Y/Pb/Pr) capability, then you may connect the component video outputs of your source to one of the two component video inputs. Do not make any other video connections to that source.

Component Video Monitor Outputs: If you are using either of the Component Video Inputs and your television or video display is component-video-capable, connect these jacks to the corresponding inputs on your video display. In addition, connect the composite and/or S-video monitor outputs to your video display to view the AVR 154's on-screen menu displays.

HDMI™ Inputs and Output: HDMI (High-Definition Multimedia Interface) is a newer type of connection for transmitting digital audio and video signals between devices. Although the AVR 154 is not capable of processing HDMI signals, if your video display is HDMI-capable, connect up to three HDMI sources here, and then connect the HDMI Output to your video display for improved video performance. Disable the HDMI audio function of your video display, and make a separate digital audio connection from the source device to one of the AVR's coaxial or optical digital audio inputs to benefit from the AVR 154's multichannel audio processing.

NOTE: The AVR 154 does not convert other types of video to HDMI, and you will not be able to view the on-screen displays using the HDMI connection.

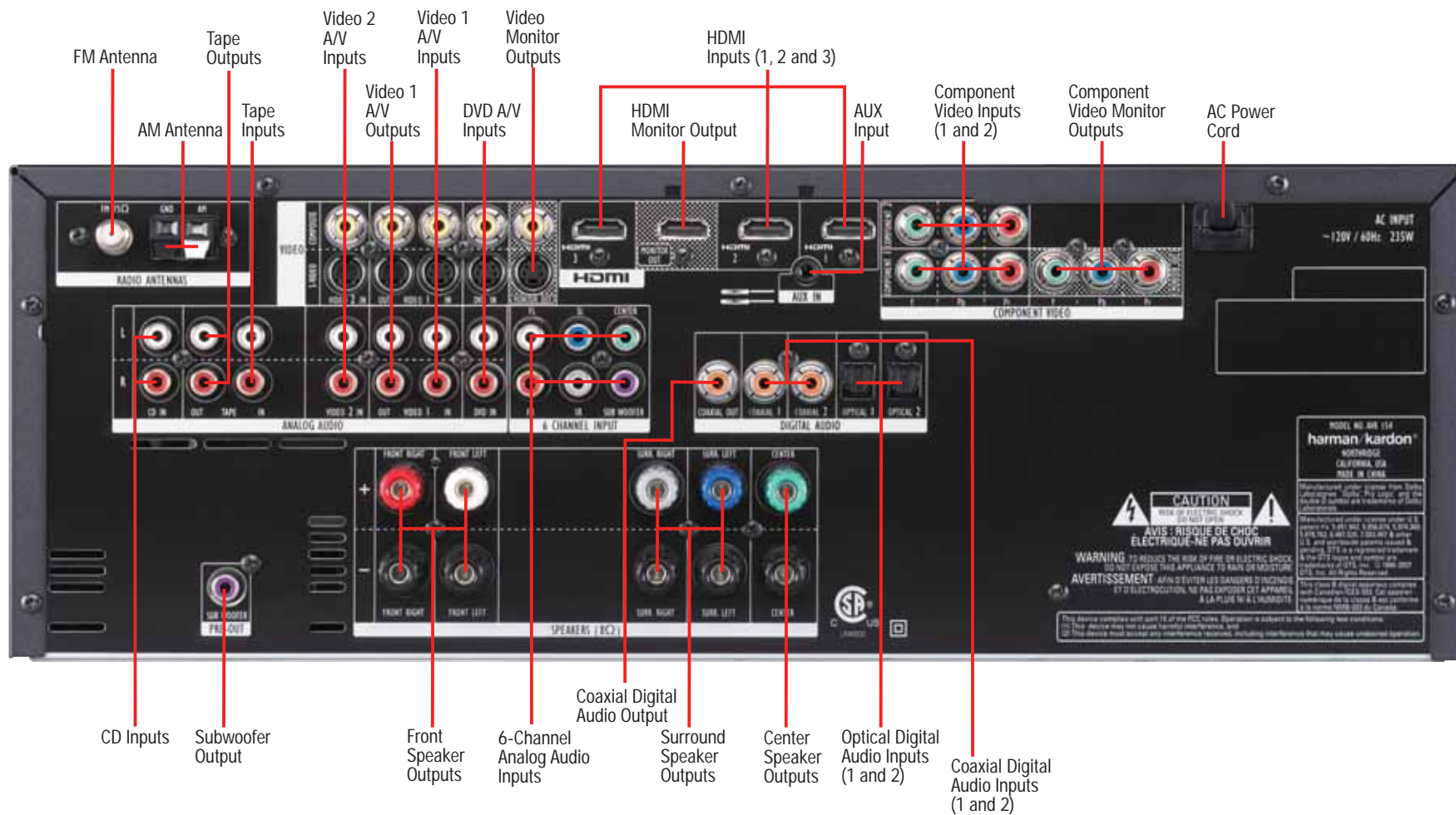

NOTE: To make it easier to follow the instructions throughout the manual that refer to this illustration, a copy of this page may be downloaded from the Product Support section at www.harmankardon.com.

REMOTE CONTROL FUNCTIONS

The AVR 154 remote is capable of controlling up to 11 devices, including the AVR itself and a device connected to the Auxiliary Input. During the installation process, you may program the codes for each of your source components into the remote. Each time you wish to use the codes for any component, first press the Selector button for that component. This changes the button functions to the appropriate codes.

Each Input Selector has been preprogrammed to control certain types of components, with only the codes specific to each brand and model changing, depending on which product code is programmed. The device types programmed into each selector, except the HDMI selectors, may not be changed.

DVD: Controls DVD players and recorders.

CD: Controls CD players and recorders.

Tape: Controls cassette decks.

Video 1: Controls VCRs, TiVo® devices and DVRs, and the Harman Kardon DMC 1000 digital media center.

Video 2: Controls cable and satellite television set-top boxes.

Video 3: Controls televisions and other video displays.

HDMI 1, 2 and 3: Each code set controls a source device (VCR/PVR/DVD player or cable/satellite set-top box) connected to one of these inputs.

AUX: Controls a device connected to the Auxiliary Input.

Any given button may have different functions, depending on which component is being controlled. Some buttons are labeled with these functions. For example, the Sleep and DSP Surround Buttons are labeled for use as Channel Up/Down Buttons when controlling a television or cable box. See Table A8 in the appendix for listings of the different functions for each type of component.

IR Transmitter Lens: As buttons are pressed on the remote, infrared codes are emitted through this lens. Make sure it is pointing toward the component being operated.

Power On Button: Press this button to turn on the AVR or another device. The Main Power Switch on the AVR 154's front panel must first have been switched on.

Mute Button: Press this button to mute the AVR 154's speaker and headphone outputs temporarily. To end the muting, press this button or adjust the volume. Muting is also canceled when the receiver is turned off.

Program Indicator: This LED lights up or flashes in one of three colors as the remote is programmed with codes.

Power Off Button: Press this button to turn off the AVR 154 or another device.

AVR Selector: Press this button to switch the remote to the codes that operate the receiver.

Input Selectors: Press one of these buttons to select a source device, which is a component where a playback signal originates, e.g., DVD, CD, cable TV, satellite or HDTV tuner. This will also turn on the receiver and switch the remote's mode to operate the source device.

AM/FM Button: Press this button to select the tuner as the source, or to switch between the AM and FM bands.

6-Channel Input Selector: Press this button to select the 6-Channel Inputs as the audio source. If a signal is present at the component video inputs assigned to this source, it will be used. If not, the receiver will use the video input and remote control codes for the last-selected analog video source.

Test Tone: Press this button to activate the test tone for manual output-level calibration.

TV/Video: This button has no effect on the receiver, but is used to switch video inputs on some video source components.

Sleep Button: Press this button to activate the sleep timer, which turns off the receiver after a programmed period of time of up to 90 minutes.

Volume Controls: Press these buttons to raise or lower the volume, which will be shown in decibels (dB) in the Message Display.

DSP Surround: Press this button to select a DSP surround mode (Hall 1, Hall 2, Theater).

On-Screen Display (OSD): Press this button to activate the on-screen menu system.

Channel Level: Press this button to adjust the output levels for each channel so that all speakers sound equally loud at the listening position. Usually this is done while playing an audio selection, such as a favorite CD, after you have configured the speakers, as described in the Initial Setup section.

Speaker Setup: Press this button to configure speaker sizes, that is, the low-frequency capability of each speaker. Usually this is done using the on-screen menu system, as described in the Initial Setup section.

Navigation (▲/▼/◀/▶) and OK Buttons: These buttons are used to make selections within the on-screen menu system, or when accessing the functions of the four buttons surrounding this area of the remote – Channel Level, Speaker Setup, Digital Input or Delay.

Digital Input Select: Press this button to select the specific digital audio input (or analog audio input) you used for the current source.

Delay: Press this button to set delay times that compensate for placing the speakers at different distances from the listening position, or to resolve a "lip sync" issue that may be caused by digital video processing. This may also be done using the on-screen menu system, as described in the Initial Setup section.

Numeric Keys: Use these buttons to enter radio station frequencies or to select station presets. Press the Direct Button before entering the station frequency.

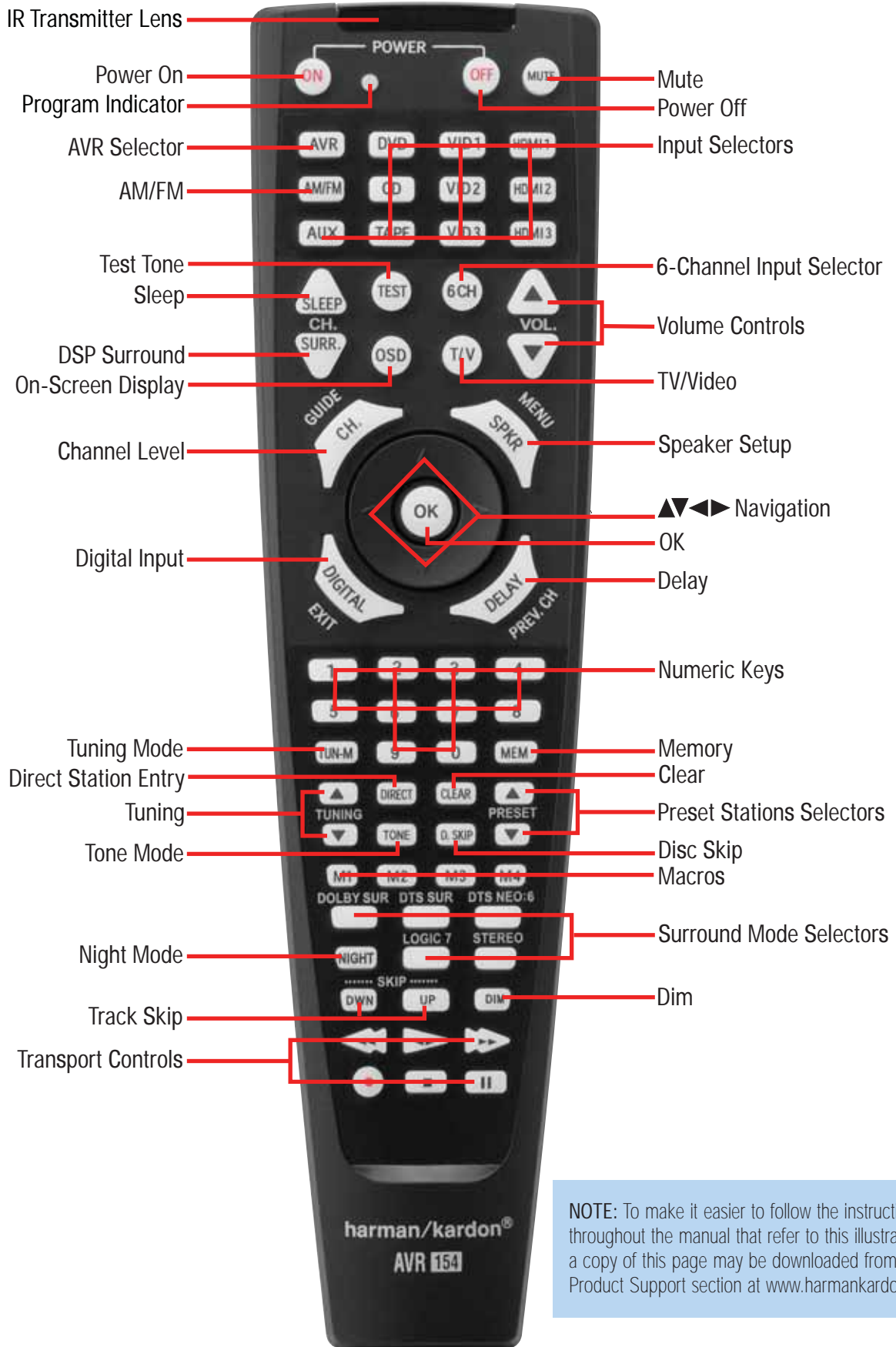

REMOTE CONTROL FUNCTIONS

Tuning Mode: This button toggles between manual (one frequency step at a time) and automatic (seeks frequencies with acceptable signal strength) tuning mode. It also toggles between stereo and mono modes when an FM station is tuned.

Memory: After you have tuned a particular radio station, press this button, then the numeric keys, to save that station as a radio preset.

Tuning: Press these buttons to tune a radio station. Depending on whether the tuning mode has been set to manual or automatic, each press will either change one frequency step at a time, or seek the next frequency with acceptable signal strength.

Direct: Press this button before using the Numeric Keys to directly enter a radio station frequency.

Clear: Press this button to clear a radio station frequency you have started to enter.

Preset Stations Selector: Press these buttons to select a preset radio station.

Tone Mode: Press this button to access the tone controls (bass and treble). Use the Navigation Buttons to make your selections.

Disc Skip: This button has no effect on the receiver, but is used with some optical disc changers to skip to the next disc.

Macros: These buttons may be programmed to execute long command sequences with a single button press. They are useful for programming the command to turn on or off all of your components, or for accessing specialized functions for a different component than you are currently operating.

Surround Mode Selectors: Press any of these buttons to select a type of surround sound (e.g., multichannel) mode. Choose from the Dolby modes, DTS modes, Logic 7 modes or Stereo modes. Each press of a button will cycle to the next available variant of that mode. Not all modes or mode groups are available with all sources.

Night Mode: Press this button to activate Night mode with specially encoded Dolby Digital discs or broadcasts. Night mode compresses the audio so that louder passages are reduced in volume to avoid disturbing others, while dialogue remains intelligible.

Track Skip: These buttons have no effect on the receiver, but are used with many source components to change tracks or chapters.

Dim: Press this button to partially or fully dim the front-panel display.

Transport Controls: These buttons have no effect on the receiver, but are used to control many source components. By default, when the remote is operating the receiver, these buttons will control a DVD player.

CONNECTIONS

There are different types of audio and video connections used to connect the receiver to the speakers and video display, and to connect the source devices to the receiver. To make it easier to keep them all straight, the Consumer Electronics Association (CEA) has established a color-coding standard. See Table 1.

Table 1 – Connection Color Guide

Audio Connections	
Front (FL/FR)	Left (White) Right (Red)
Center (C)	Green
Surround (SL/SR)	Blue (SL) Grey (SR)
Subwoofer (SUB)	Purple
Digital Audio Connections	
Coaxial	Orange
Optical	Input (Black)
Video Connections	
Component	Y (Green) Pb (Blue) Pr (Red)
Composite	Yellow
S-Video	Circle with S
HDMI™ Connections (switching only)	
HDMI	Black

Types of Connections

This section will briefly review different types of cables and connections.

Speaker Connections

Speaker cables carry an amplified signal from the receiver's speaker terminals to each loudspeaker. Speaker cables generally contain two wire conductors, or leads, inside plastic insulation. The two conductors are usually differentiated in some way, by using different colors, or stripes, or by adding a ridge to the insulation. Sometimes the wires are different colors, e.g., copper-colored and silver.

The differentiation is important because each speaker must be connected to the receiver's speaker-output terminals using two wires, one positive (+) and one negative (-). This is called speaker polarity. It's important to maintain the proper polarity for all speakers in the system, or performance can suffer, especially for the low frequencies.

Always connect the positive terminal on the loudspeaker, which is usually colored red, to the positive terminal on the receiver, which is colored as shown in the Connection Color Guide (Table 1). Similarly, always connect the black negative terminal on the speaker to the black negative terminal on the receiver.

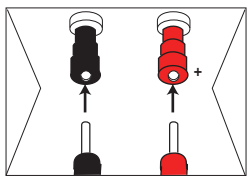

Figure 1 – Binding-Post Speaker Terminals With Banana Plugs

The AVR 154 uses binding-post speaker terminals that can accept banana plugs or bare-wire cables.

Banana plugs are simply plugged into the hole in the middle of the terminal cap. See Figure 1.

Bare wire cables are installed as follows (see Figure 2):

1. Unscrew the terminal cap until the pass-through hole in the collar is revealed.
2. Insert the bare end of the wire into the hole.
3. Screw the cap back into place until the wire is held snugly.

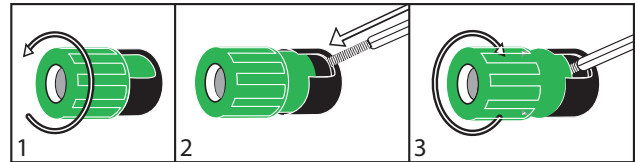

Figure 2 – Binding-Post Speaker Terminals With Bare Wires

Subwoofer

The subwoofer is a specialized type of loudspeaker used to play only the low frequencies (bass), which require much more power than the other speaker channels. In order to obtain the best results, most speaker manufacturers offer powered subwoofers, in which the speaker contains its own amplifier on board. Usually, a line-level (nonamplified) connection is made from the receiver's Subwoofer Output to a corresponding jack on the subwoofer, as shown in Figure 3, but sometimes the subwoofer is connected to the receiver using the front left and right speaker outputs, and then the front left and right speakers are connected to terminals on the subwoofer.

Although the subwoofer output looks similar to the analog audio jacks used for the various components, it is filtered and only allows the low frequencies to pass. Don't connect this output to your other devices. Although doing so won't cause any harm, performance will suffer.

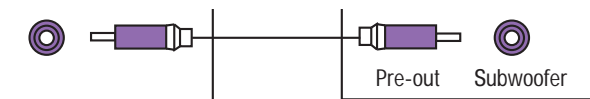

Figure 3 – Subwoofer

Connecting Source Devices to the AVR

The AVR 154 is designed to process audio and video input signals, playing back the audio and displaying the video on a television or monitor connected to the AVR. These signals originate in what are known as "source devices," including your DVD player, CD player, DVR (digital video recorder) or other recorder, tape deck, game console, cable or satellite television box or MP3 player. Although the tuner is built into the AVR, it also counts as a source, even though no external connections are needed, other than the FM and AM antennas.

Separate connections are required for the audio and video portions of the signal. The types of connections used depend upon what's available on the source device, and for video signals, the capabilities of your video display.

CONNECTIONS

Audio Connections

There are two formats for audio connections: digital and analog. Digital audio signals are required for listening to sources encoded with digital surround modes, such as Dolby Digital and DTS. The AVR 154 uses two types of digital audio connections: coaxial and optical. Either type of digital audio connection may be used for each source device, but never both simultaneously for the same source. However, it's okay to make both analog and digital audio connections to the same source.

NOTE: Although HDMI cables are capable of carrying digital audio signals, the AVR 154 is not designed to process those signals. Therefore, if your source and video display are both HDMI-capable, use the HDMI connections for video only. Make a separate audio connection from the source device to the AVR 154, and consult the owner's manual for the source device for instructions on muting the device's HDMI audio output.

Digital Audio

Coaxial digital audio jacks are usually color-coded in orange. Although they look similar to analog jacks, they should not be confused, and you should not connect coaxial digital audio outputs to analog inputs or vice versa. See Figure 4.



Figure 4 – Coaxial Digital Audio

Optical digital audio connectors are normally covered by a shutter to protect them from dust. The shutter opens as the cable is inserted. Input connectors are color-coded using a black shutter, while outputs use a gray shutter. See Figure 5.



Figure 5 – Optical Digital Audio

Analog Audio

Analog connections require two cables, one for the left channel (white) and one for the right channel (red). These two cables are often attached to each other for most of their length. See Figure 6. Most sources that have digital audio jacks also have analog audio jacks, although some older types of sources, such as tape decks, have only analog jacks. For sources that are capable of both digital and analog audio, you may wish to make both connections. If you wish to record materials from DVDs or other copy-protected sources, you may only be able to do so using analog connections. Remember to comply with all copyright laws if you choose to make a copy for your own personal use.

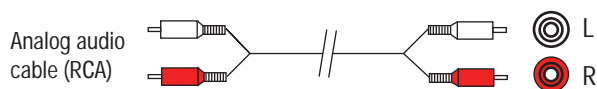

Figure 6 – Analog Audio

Multichannel analog connections are used with some high-definition sources where the copy-protected digital content is decoded inside

the source. These types of connections are usually used with DVD-Audio, SACD, Blu-ray Disc, HD-DVD and other multichannel players. See Figure 7.

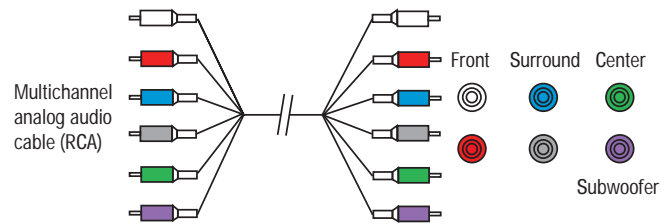

Figure 7 – Multichannel Analog Audio

NOTE: When using the 6-Channel Analog Audio Inputs, make an analog video connection for the device. To enjoy a multi-channel disc, select the source input for the video connection, e.g., DVD, or simply use the component video inputs assigned to the 6-Channel Analog Audio Inputs (see Initial Setup section for an explanation on assigning video inputs), then select the 6-Channel Analog Audio Inputs as the source. If no signal is present at the component video inputs assigned to the 6-Channel Analog Audio Inputs, the AVR 154 will use the last-selected analog video input, which is DVD in this example. It is not possible to select an HDMI input for video while using the 6-Channel Analog Audio Inputs for audio.

The AVR 154 also offers an Auxiliary Audio Input on the rear panel in the form of a stereo 1/8" mini jack. Connect the headphone output of any audio source, such as an MP3 player or portable CD player, to the Auxiliary Audio Input. See Figure 8.



Figure 8 – Auxiliary Audio Input

Video Connections

Although some sources produce an audio signal only (e.g., CD player, tape deck), many sources output both audio and video signals (e.g., DVD player, cable television box, HDTV tuner, satellite box, VCR, DVR). In addition to the audio connection, make one type of video connection for each of these sources (but only one at a time for any source).

Digital Video

The AVR 154 is equipped with three HDMI (High-Definition Multimedia Interface) inputs, and one output. HDMI is capable of carrying digital audio and video information using a single cable, thus delivering the highest possible quality picture and sound.

The AVR 154 is capable of switching the HDMI data, passing the incoming audio and video data (including 1080i and 1080p video), directly to your HDMI-capable video display, without processing any of the data. Although the AVR 154 is compatible with virtually any HDMI-capable source device and video display, a separate audio connection is required for each source, since the AVR 154 doesn't have access to the audio data in the HDMI stream.

CONNECTIONS

The AVR 154 will not convert analog video signals to the HDMI format, and the on-screen displays are not visible when using an HDMI source. Connect the composite or S-video monitor output (or both, depending on which video connections your sources use) to your video display to view the on-screen menus.

The physical HDMI connection is simple. The connector is shaped for easy plug-in (see Figure 9). If your video display has a DVI input, you may use an HDMI-to-DVI adapter (not included) to connect it to the AVR's HDMI Output, but the HDMI-to-DVI connection will not carry audio. In addition, your DVI-equipped display should be HDCP (High-Definition Copy Protection)-compliant.

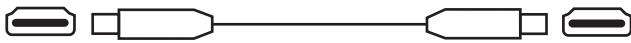

Figure 9 – HDMI Connection

Analog Video

There are three types of analog video connections: composite video, S-video and component video.

Composite video is the basic connection most commonly available. The jack is usually color-coded yellow, and looks like an analog audio jack, although it is important never to confuse the two. Do not plug a composite video cable into an analog or coaxial digital audio jack, or vice versa. Both the chrominance (color) and luminance (intensity) components of the video signal are transmitted using a single cable. See Figure 10.



Figure 10 – Composite Video

S-video, or "separate" video, transmits the chrominance and luminance components using separate wires contained within a single cable. The plug on an S-video cable contains four metal pins, plus a plastic guide pin. Be careful to line up the plug correctly when you insert it into the jack on the receiver, source or video display. See Figure 11.

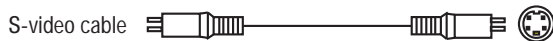

Figure 11 – S-Video

Component video separates the video signal into three components – one luminance ("Y") and two subsampled color signals ("Pb" and "Pr") – that are transmitted using three separate cables. The "Y" cable is color-coded green, the "Pb" cable is colored blue and the "Pr" cable is colored red. See Figure 12.

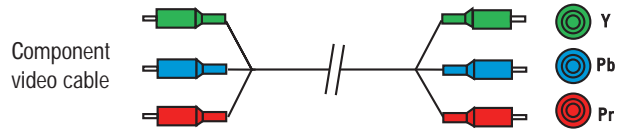

Figure 12 – Component Video

If it's available on your video display, HDMI is recommended as the best quality connection, followed by component video, S-video and then composite video.

NOTES:

- A composite or S-video connection to your TV is required to view the AVR's on-screen displays.
- Copy-protected sources are not available at the Component Video Monitor Outputs.

Antennas

The AVR 154 uses separate terminals for the included FM and AM antennas that provide proper reception for the tuner.

The FM antenna uses a 75-ohm F-connector. See Figure 13.

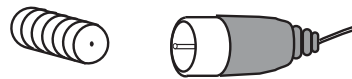

Figure 13 – FM Antenna

The AM loop antenna needs to be assembled. Then connect the two leads to the push-type terminals on the receiver. Although the terminals are color-coded, you may connect either antenna lead to either terminal. See Figure 14.

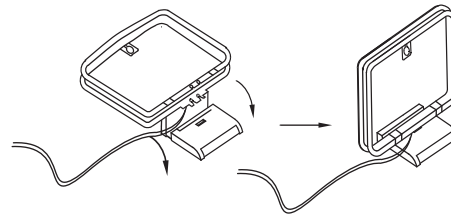

Figure 14 – AM Antenna

INSTALLATION

You are now ready to connect your various components to your receiver. Before beginning, turn off all components, including the AVR 154, and unplug their power cords. **Don't plug any of the power cords back in until you have finished making all of your connections.**

Remember that your receiver generates heat while it is on. Select a location that leaves several inches of space on all sides of the receiver. Avoid completely enclosing the receiver inside an unventilated cabinet. It is preferable to place components on separate shelves rather than stacking them directly on top of the receiver. Some surface finishes are delicate. Try to select a location with a sturdy surface finish.

Step One – Connect the Speakers

If you have not yet done so, place your speakers in the listening room as described in the Speaker Placement section above.

Connect the center, front left, front right, surround left and surround right loudspeakers to the corresponding speaker terminals on the AVR 154. See Figure 16. Maintain the proper polarity by always connecting the positive and negative terminals on each speaker to the positive and negative terminals on the receiver. Use the Connection Color Guide on page 16 as a reference.

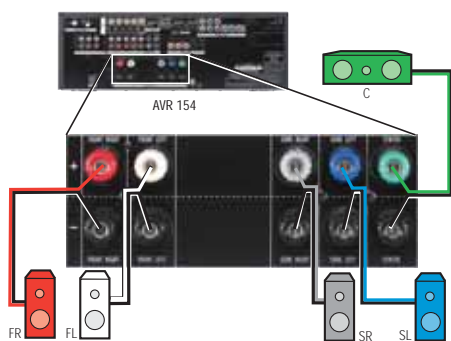

Figure 16 – Speaker Connections

Step Two – Connect the Subwoofer

Connect the Subwoofer Output on the AVR 154 to the line-level input on your subwoofer. See Figure 17. Consult the manufacturer's guide for the subwoofer for additional information.

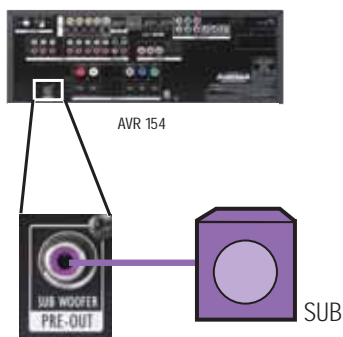

Figure 17 – Subwoofer Connection

Step Three – Connect the Antennas

Connect the FM and AM antennas to their terminals. See Figure 18.

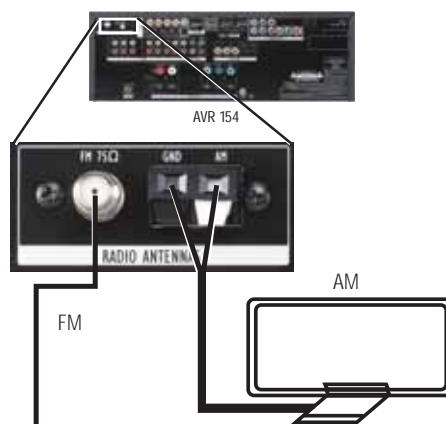

Figure 18 – Antenna Connections

Step Four – Connect the Source Components

Use the Table A5 worksheet in the Appendix to note which connections you will use for each of your source devices.

A source is a device where the audio and video signals originate. Some sources, such as CD players, only offer audio, while sources used for watching movies or broadcast-television programming deliver a video signal as well.

Referring to the photograph of the AVR 154 remote control on page 13, there is a section of 12 buttons near the top of the remote designated "Input Selectors": DVD, AM/FM, CD, AUX, TAPE, VID1, VID2, VID3, HDMI1, HDMI2, HDMI3 and 6CH. Each of these buttons corresponds to a set of input connectors on the AVR. The set of connectors is referred to as a "source input".

The goal of Step Four of the Installation is to match up each of your source devices, e.g., DVD player and cable television box, with the correct connectors on the AVR 154.

We recommend that you refer to Table A1 in the appendix when making these connections. Although you may connect a source to any source input with the matching types of connectors, by selecting the source input dedicated to the same type of component, you will be able to program the AVR's universal remote to control it, simplifying operation.

The precise connections to be made depend on the capabilities of the source device and your video display (TV). Select the best audio and video connections for each source. The types of connections are listed in order of preference:

Audio Connections

- Choose one digital audio connection: Optical or Coaxial
- Optional, or where digital audio is not available: Analog audio for making recordings for personal use or as a backup. Analog audio is required for older analog sources that don't have digital audio outputs, such as cassette decks.

INSTALLATION

Video Connections:

(choose only one, and make sure that type is available on your TV)

- HDMI
- S-video
- Component video
- Composite video

NOTES:

- Digital audio, HDMI and component video connections are not dedicated to any source input. When any of these physical connections are used, they must be assigned to the desired source input as described in the Initial Setup section. It's possible for a source input to use none of the connectors named for it; e.g., the DVD source may use the Component Video 1 inputs for video and the Coaxial Digital Audio Input 1 for audio, both of which require assignment.
- If the video display is equipped with an HDMI or DVI digital video input, make sure it is also HDCP-compliant (High-Bandwidth Digital Content Protection) to display copy-protected materials.
- If the source or video display has a DVI input, use an HDMI-to-DVI adapter (not included), and make separate audio connections.
- Although the 6-Channel Analog Audio Inputs are designated as a separate source input, the 6CH button on the remote may not be programmed to operate a source device. The 6-Channel Analog Audio Inputs are used with an analog video input (component video, S-video or composite video, but not HDMI) that may also be assigned to another source input, such as DVD. Program the corresponding Input Selector on the remote, e.g., DVD, with the device's product code. To enjoy audio from the 6-Channel Analog Audio Inputs, first select the source for the video input (DVD, in this example), and then switch the source to the 6-Channel Analog Audio Inputs. The AVR 154 will use the last-selected analog video input while obtaining audio from the 6-Channel Analog Audio Inputs.

Connect a DVD, SACD, HD-DVD or Blu-ray Disc Player

HDMI Video: If the DVD player and the TV both have an HDMI connector, connect the player as follows (see Figure 19):

- Connect the DVD player's HDMI output to the HDMI 1 Input on the AVR.
- Connect the DVD player's coaxial digital audio output to the Coaxial 2 input on the AVR.

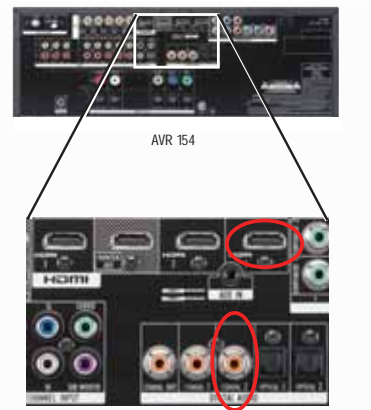

Figure 19 – Connecting an HDMI-Equipped Disc Player

If the player is capable of playing multichannel discs, including DVD-Audio, SACD, HD-DVD and Blu-ray Disc, make the following additional connections (see Figure 20):

- Connect the DVD player's component video output to the Component Video 1 Input on the AVR.
- Connect the DVD player's 6-channel analog audio outputs to the 6-Channel Analog Audio Inputs on the AVR.

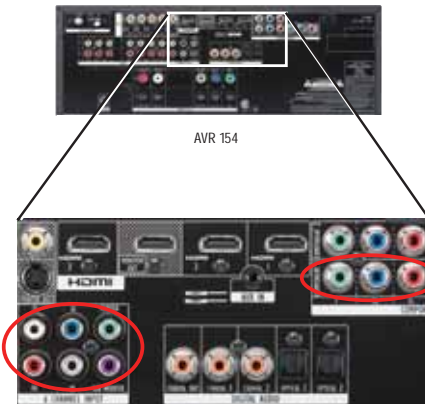

Figure 20 – Connecting a Multichannel Audio Player

Component Video: If the DVD player or the TV does not have an HDMI connector, but they both have component video connectors, connect the player as follows (see Figure 21):

- Connect the DVD player's component video output to the Component Video 1 Input on the AVR.
- Connect the DVD player's coaxial digital audio output to the Coaxial 1 input on the AVR.

INSTALLATION

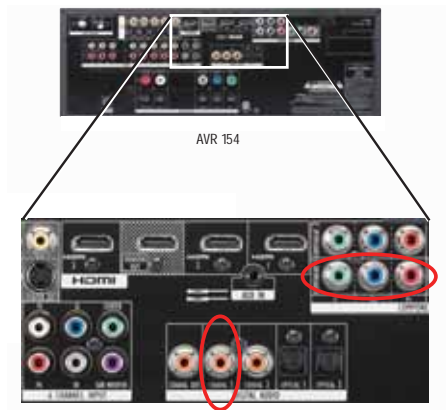

Figure 21 – Connecting a Component-Video-Equipped Disc Player

If the player is capable of playing multichannel discs, including DVD-Audio, SACD, HD-DVD and Blu-ray Disc, make the following additional connection (see Figure 20):

- Connect the DVD player's 6-channel analog audio outputs to the 6-Channel Analog Audio Inputs on the AVR.

Composite/S-Video: If the best video connection common to both the DVD player and the TV is either S-video or composite video, follow these steps (see Figure 22):

- Connect the DVD player's S-video or composite video output (use one connection only) to the corresponding DVD Video Input on the AVR.
- Connect the DVD player's coaxial digital audio output to the Coaxial 1 input on the AVR.

If the player is capable of playing multichannel discs, including DVD-Audio, SACD, HD-DVD and Blu-ray Disc, make the following additional connection (see Figure 22):

- Connect the DVD player's 6-channel analog audio outputs to the 6-Channel Analog Audio Inputs on the AVR.

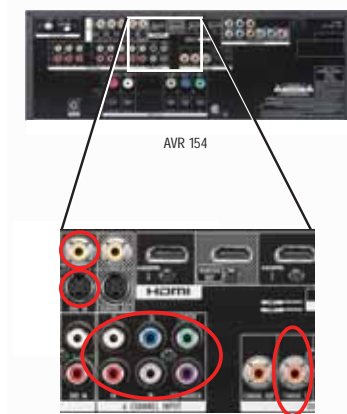

Figure 22 – Connecting a Composite- or S-Video-Equipped Disc Player

NOTES:

- Where a given type of connection is called for, e.g., HDMI, component video or digital audio, you may use any available input of that type. We recommend connections solely because they are assigned by default to certain source inputs.
- If you wish to make recordings from a DVD, use the DVD S-video or composite video input, and the DVD Analog Audio inputs in addition to any other connections. The AVR cannot make recordings from HDMI or component video sources, and digital audio sources may only be recorded in two channels.
- You may connect the DVD player to the Video 1, Video 2 or Video 3 source inputs, but you will then be unable to program the AVR remote to operate the player.
- Connect a Harman Kardon DMC 1000 digital media center to any available HDMI Input for digital video and any available input for digital audio, or to the Video 1 Audio/Video Inputs for analog audio and video. You may make both the analog and digital audio and video connections, depending on your system requirements.

Connect an Audio/Video Recorder (PVR, DVR or TiVo)

HDMI Video: If the recorder and the TV both have an HDMI connector, connect the recorder as follows (see Figure 23):

- Connect the recorder's HDMI output to the HDMI 2 Input on the AVR.
- Connect the recorder's optical digital audio output to the Optical 2 input on the AVR.
- Then go to "Composite/S-Video" on page 23 to make recordings, as the AVR 154 cannot make recordings from digital audio (except 2-channel) and video sources.



Figure 23 – Connecting an HDMI-Equipped Recorder

Component Video: If the recorder or the TV does not have an HDMI connector, but they both have component video connectors, connect the recorder as follows (see Figure 24):

- Connect the recorder's component video output to the Component Video 2 Input on the AVR.

INSTALLATION

- Connect the recorder's optical digital audio output to the Optical 2 Input on the AVR (if available).
- Then go to "Composite/S-Video" below to make recordings, as the AVR 154 cannot make recordings from copy-protected component video sources or digital audio (except 2-channel) sources.

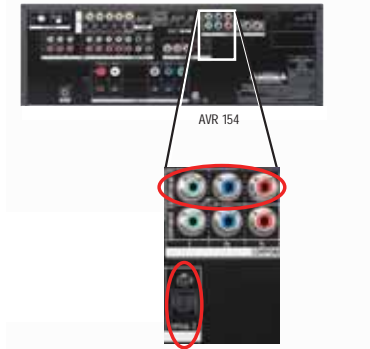

Figure 24 – Connecting a Component-Video-Equipped Recorder

Composite/S-Video: If the best video connection common to both the recorder and the TV is either S-video or composite video, or to make recordings, follow these steps, using only one type of video connection throughout (see Figure 25):

- Connect the recorder's S-video/composite video output to the Video 1 S-Video/Composite Video Input on the AVR.
- Connect the recorder's S-video/composite video input to the Video 1 S-Video/Composite Video Output on the AVR.
- Connect the recorder's analog audio outputs to the Video 1 Audio Inputs on the AVR.
- Connect the recorder's analog audio inputs to the Video 1 Audio Outputs on the AVR.



Figure 25 – Connecting a Video Recorder

NOTE: If S-video or composite video is the only video connection, you may also use any available digital audio connection.

Connect a Cable TV, Satellite, HDTV or Other Set-Top Box for Broadcast Television

NOTE: If you receive your television programming using your TV with an antenna or direct cable connection, connect the TV's analog audio outputs to the Video 3 Analog Audio Inputs. If the TV has a digital audio output, connect it to one of the front-panel digital audio inputs. *Do not* connect any video output on the television set to any video input on the receiver. See Step Five for information on connecting the receiver's video monitor outputs to the television.

HDMI Video: If the set-top box and the TV both have an HDMI connector, connect the set-top box as follows (see Figure 26):

- Connect the set-top's HDMI output to the HDMI 3 Input on the AVR.
- Connect the set-top's optical digital audio output to the Optical 1 Input on the AVR (if available).

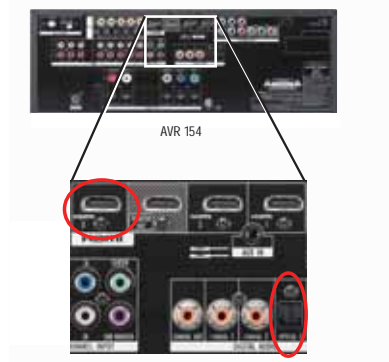

Figure 26 – Connecting an HDMI-Equipped Set-Top Box

Component Video: If the set-top box or the TV does not have an HDMI connector, but they both have component video connectors, connect the set-top box as follows (see Figure 27):

- Connect the set-top's component video output to the Component Video 2 Input on the AVR (if available).
- Connect the set-top's optical digital audio output to the Optical 1 Input on the AVR (if available).

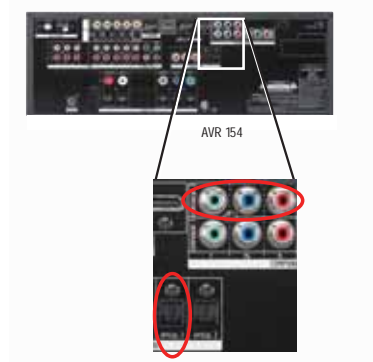

Figure 27 – Connecting a Component-Video-Equipped Set-Top Box

INSTALLATION

Composite/S-Video: If the best video connection common to both the set-top box and the TV is either S-video or composite video, follow these steps (see Figure 28):

- Connect the set-top's S-video or composite video output (use one connection only) to the corresponding Video 2 Input on the AVR.
- Connect the set-top's optical digital audio output to the Optical 1 Input on the AVR (if available). For fully analog set-top boxes, connect the box's analog audio outputs to the AVR's Video 2 Audio Inputs.

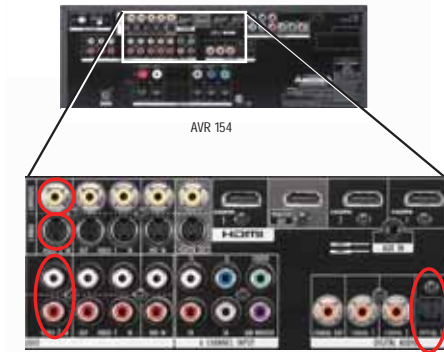

Figure 28 – Connecting a Set-Top Box

Connect a CD Player or Any Audio-Only Device

If the CD player or other component has a digital audio output, connect it to any available digital audio input on the AVR. If not, connect the CD player's left and right analog audio outputs to the CD Audio Inputs. No video connection is required, but the AVR will display the last-selected analog video source when the CD source is selected. See Figure 29.

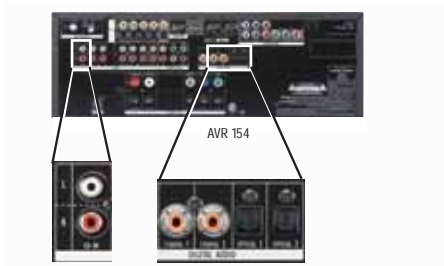

Figure 29 – Connecting a CD Player

NOTE: A turntable may only be connected to the AVR if it is equipped with an internal phono preamp, or if you supply an external phono preamp, available at some audio specialty stores or through the Harman Kardon Parts Dept. You may then connect it to any set of analog audio inputs.

Connect a Tape Deck or Any Audio-Only Recorder

If the recorder has digital audio inputs and outputs, connect either its coaxial or optical digital audio output (not both) to the corresponding available input on the AVR, and connect the AVR's Coaxial Digital Audio Output to the recorder's coaxial digital audio input.

To make analog audio recordings, connect the recorder's left and right analog audio outputs to the Tape Inputs on the AVR, and the recorder's analog audio inputs to the AVR's Tape Outputs.

No video connection is required, although the AVR will display the last-selected analog video source when the Tape source is selected. See Figure 30.

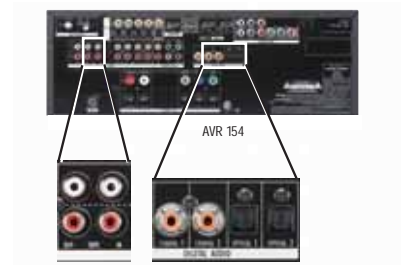

Figure 30 – Connecting an Audio Recorder

Connect a Portable Audio Player

For audio-only playback from a portable CD player, cassette deck, MP3 player or other device equipped with a 1/8-inch headphone jack, use a stereo 1/8-inch mini-plug interconnect (not included) to connect the device's headphone jack to the AUX Input on the AVR. Use the device's own controls to operate it. See Figure 31.

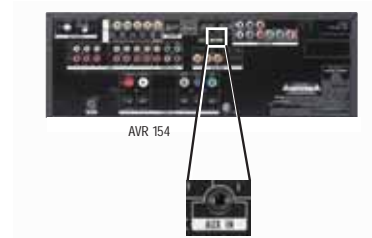

Figure 31 – Connecting a Portable Audio Player

Alternatively, use an interconnect with a stereo 1/8-inch mini-plug at one end and two RCA plugs at the other end to connect the player to the Video 3 Audio Inputs on the AVR's front panel (see Figure 32).

Connecting a Game Console, Camera or Other Device

If a device will only be connected temporarily, you may use the Video 3 Inputs on the front panel. When not in use, place the supplied covers over the Video 3 jacks for a cleaner appearance by snapping the covers in place. To remove the covers, gently press on the left side of each cover so that it pivots out.

Video Components: Install video components, e.g., game consoles and camcorders, as follows (see Figure 32):

- Connect the component's S-video or composite video output (use only one connection) to the corresponding Video 3 Input on the AVR.
- Connect the component's optical or coaxial digital audio output to either the Optical 3 or Coaxial 3 Input on the front panel (if available). For fully analog devices, connect the device's analog audio outputs to the AVR's Video 3 Audio Inputs.

INSTALLATION

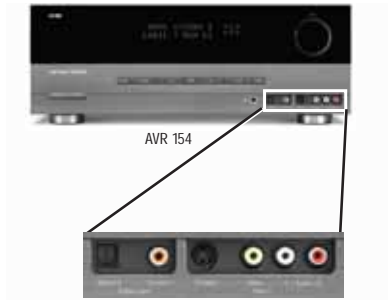

Figure 32 – Connecting a Device to the Front-Panel Inputs

Audio Components: Connect audio-only devices, such as CD players, to either the Coaxial 3 or Optical 3 Digital Audio Inputs, or the Video 3 Analog Audio Inputs (see Figure 32). If you obtain your broadcast programming from the TV, connect its audio outputs to the front-panel inputs and program the AVR remote to operate the TV, as described in Step Eight.

NOTE: If your video devices are equipped with HDMI or component video outputs, you may connect them to any available audio and video input on the AVR.

Step Five – Connect the Video Display

IMPORTANT NOTE: Do not connect any video output on the video display (TV) to any video input on the AVR. Doing so may cause undesirable video interference.

HDMI Video: If the display has an HDMI input, and if any sources are connected to any of the AVR's HDMI Inputs, connect the HDMI Monitor Output to the display (see Figure 33). Go to "Composite/S-Video" below for an additional required connection.

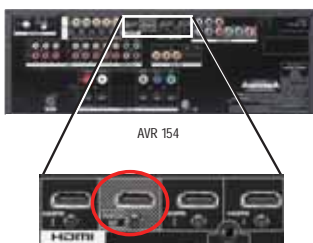

Figure 33 – HDMI Monitor Output

Component Video: If the display has component video inputs, and if any sources are connected to either of the AVR's Component Video Inputs, connect the Component Video Monitor Outputs to the display (see Figure 34). Go to "Composite/S-Video" below for an additional required connection.

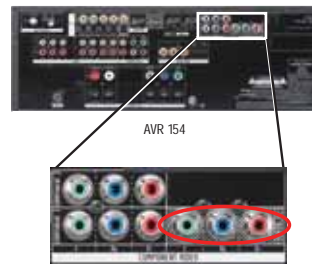

Figure 34 – Component Video Monitor Outputs

Composite/S-Video: Important – do not skip this step, even if you have connected the AVR's HDMI or Component Video Monitor Outputs to the display. To view the AVR's on-screen menus and messages, connect either the Composite or S-Video Monitor Output to the display. In addition, if any sources are connected to the AVR via a composite or S-video connection, connect the corresponding Monitor Output to the display. See Figure 35.



Figure 35 – Composite and S-Video Monitor Outputs

Consult the manual for your TV to make sure you understand how to select each video input. As you play different source devices that use different types of video connections, select the correct video input on your video display.

Step Six – Plug in AC Power

Having made all of your wiring connections, it is now time to plug each component's AC power cord into a working outlet.

Before plugging the AVR 154's AC Power Cord into an electrical outlet, make sure that the Master Power Switch on the front panel is popped out so that the word OFF appears on its top. Gently press the button to turn the switch off. This will prevent the possibility of damaging the AVR in case of a transient power surge.

Step Seven – Insert Batteries in Remote

The AVR 154 remote control uses three AAA batteries, which are included.

To remove the battery cover located on the back of the remote, firmly press the ridged depression and slide the cover toward the top of the remote.

Insert the batteries as shown in Figure 36, making sure to observe the correct polarity.

INSTALLATION



Figure 36 – Remote Control Battery Compartment

When using the remote, remember to point the lens toward the front panel of the AVR 154. Make sure no objects, such as furniture, are blocking the remote's path to the receiver. Bright lights, fluorescent lights and plasma video displays may interfere with the remote's functioning. The remote has a range of about 20 feet, depending on the lighting conditions. It may be used at an angle of up to 30 degrees to either side of the AVR.

If the remote seems to operate intermittently, or if pressing a button on the remote does not cause the AVR Selector or one of the Input Selectors to light up, then make sure the batteries have been inserted correctly, or replace all three batteries with fresh ones.

Step Eight – Program Sources Into the Remote

The AVR 154 remote not only is capable of controlling the receiver, but it may also be programmed to control many brands and models of VCRs, DVD players, CD players, cable boxes, satellite receivers, cassette decks and TVs.

It may help to think of the remote as a book with pages. Each page represents the button functions for a different device. In order to access the functions for a particular device, first turn to that page; that is, switch the remote to that device mode. This is done by pressing the AVR Button to access the codes that control the receiver, or the Input Selector buttons to access the codes for the devices programmed into the remote.

The AVR 154's remote is factory-programmed to control many Harman Kardon DVD and CD players.

NOTE: The remote may be easily programmed to operate the DMC 1000 digital media center, using the Video 1 or any of the HDMI Input Selectors, by following the instructions below. Select the VCR/PVR/DMC device type in number 4. Enter code 003.

If you have other source devices in your system, follow these steps to program the correct codes into the remote.

1. Using the codes in Tables A10–A16 of the Appendix, look up the product type (e.g., DVD, cable TV box) and the brand name of your source. The number(s) listed is/are potential candidates for the correct code set for your particular device.
2. Turn on your source device.

3. This step places the remote in program mode. Refer to Figure 37. Press and hold the Input Selector until the LED on the remote starts to flash, then release it. When pressed, the Input Selector will light red briefly, go dark, and then relight when the Program Indicator LED starts to flash.
4. Program the desired device type for any of the three HDMI selectors by pressing the corresponding Input Selector:
 - Press DVD to operate a DVD player.
 - Press VID1 to operate a VCR or PVR, or a Harman Kardon digital media center.
 - Press VID2 to operate a cable or satellite set-top box.



Figure 37 – Input Selectors

5. Enter a code from number 1 above.
 - a) If the device turns off, then press the Input Selector again to accept the code; it will flash. The remote will exit the Program mode.
 - b) If the device does not turn off, try entering another code. If you run out of codes, you may search through all of the codes in the remote's library for that product type by pressing the ▲ or ▼ Button repeatedly until the device turns off. When the device turns off, enter the code by pressing the Input Selector; it will flash. The remote then exits Program mode.
6. Once you have programmed a code, try using some other functions to control the device. Sometimes manufacturers use the same Power code for several different models, while other codes vary. Repeat this process until you've programmed a satisfactory code set that operates most of the functions you frequently use.
7. Find out which code number you have programmed by pressing and holding the Input Selector to enter the Program mode. Press the OK Button, and the Program Indicator LED will flash in the code sequence. One flash represents "1", two flashes for "2", and so forth. A series of many fast flashes represents "0". Record the codes programmed for each device in Table A7 in the Appendix.

If you are unable to locate a code set that correctly operates your source device, it will not be possible to use the AVR remote to control that device. You may still connect the source to the AVR 154 and operate it using the device's original remote control.

Most of the button labels on the remote describe the button's function when used to control the AVR 154. However, the button may perform a very different function when used to control another device. Refer to

the Remote Control Function List, Table A9 in the Appendix, for each button's functions with the various product types.

You may program Macros, which are preprogrammed code sequences that execute many code commands with a single button press. You may also program "punch-through" codes, which allow the remote to operate the volume, channel or transport controls of another device without having to switch the remote's device mode. See pages 44 through 45 for instructions on these advanced programming functions.

NOTE: The AVR 154 remote is preprogrammed to operate the transport controls of Harman Kardon DVD players when the AVR or the Video 2 (cable/satellite) or Video 3 (TV) source is selected. You may change this punch-through programming at any time.

Step Nine – Turn On the AVR 154

Two steps are required the first time you turn on the AVR 154.

1. Gently press the Master Power Switch until the word OFF is no longer visible. The Power Indicator above the two power switches should light up in amber, indicating that the AVR is in Standby mode and is ready to be turned on. See Figure 38. Normally, you may leave the Master Power Switch in the ON position, even when the receiver is not being used.



Figure 38 – Power Switches

2. There are several ways in which the AVR 154 may be turned on from Standby mode.
 - a) Press the Standby/On Switch on the front panel. See Figure 38.
 - b) Press the Source Select Button on the front panel. See Figure 39.



Figure 39 – Source Select Button

- c) Using the remote, press any one of these buttons: AVR, DVD, CD, TAPE, AUX, HDMI 1, HDMI 2, HDMI 3, VID1, VID2, VID3, AM/FM or 6CH. See page 13.

NOTE: Any time you press one of the Input Selectors, the remote will switch to the corresponding device mode and will only operate that device. To control the receiver, press the AVR Button to return the remote to AVR mode.

OPERATION

Now that you have installed your system components and completed at least a basic configuration of your receiver, you are ready to begin enjoying your home theater system.

Turning On the AVR 154

Gently press the Master Power Switch until the word OFF is no longer visible. The Power Indicator above the two power switches should light up in amber. This indicates that the AVR is in Standby mode and is ready to be turned on. Normally, you may leave the Master Power Switch in the ON position, even when the receiver is not being used. See Figure 38.

There are several ways in which the AVR 154 may be turned on:

- Press the Standby/On Switch on the front panel. See Figure 38.
- Press the Source Select Button on the front panel. See Figure 39.
- Using the remote, press any one of these buttons: AVR, DVD, CD, TAPE, AUX, HDMI 1, HDMI 2, HDMI 3, VID1, VID2, VID3, AM/FM or 6CH. See page 13.

NOTE: Any time you press one of the remote's Input Selectors, the remote will switch modes so that it will only operate that device. To control the receiver, press the AVR Button to return the remote to AVR mode.

To turn the receiver off, press either the Standby/On Switch on the front panel, or press the AVR Button and the OFF Button on the remote. Unless the receiver will not be used for an extended period of time (for example, if you will be on vacation), it is not necessary to turn off the Master Power Switch. When the Master Power Switch is turned off, any settings you have programmed, including system configuration and preset radio stations, will be preserved for up to four weeks.

Sleep Timer

You may program the AVR to play for up to 90 minutes and then turn off automatically using the sleep timer.

Press the Sleep Button on the remote, and the time until turn-off will be displayed. See Figure 51. Each additional press of the Sleep Button will reduce the time until turn-off by 10 minutes, until the OFF setting is reached, which disables the sleep timer.



Figure 51 – Sleep Button

When the sleep timer has been set, the front-panel display will automatically dim to half-brightness. If you press any button on the remote or front panel, the display will return to full-brightness. The display will dim again several seconds after your last command.

If you press the Sleep Button after the timer has been set, the remaining time until turn-off will be displayed. You may press the Sleep Button to change the time until turn-off. Press and hold the Sleep Button to turn the sleep timer off.

Volume Control

The volume may be adjusted either by turning the knob on the front panel (clockwise to increase volume or counterclockwise to decrease volume), or by pressing the Volume Control Buttons on the remote. See Figure 52. The volume is displayed as a negative number of decibels (dB) below the 0dB reference point.

Unlike the volume controls on some other products, 0dB is the maximum volume for the AVR 154. Although it's physically possible to turn the volume to a higher level, doing so may damage your hearing and your speakers. For certain more dynamic audio materials, even 0dB may be too high, allowing for damage to equipment.



Figure 52 – Volume Controls

The AVR 154 is designed to reproduce audio with a minimum amount of distortion, which may lead you to think that your hearing and the equipment can handle higher volumes. We urge caution with regard to volume levels.

Mute Function

To temporarily mute all speakers and the headphones, press the Mute Button on the remote. See Figure 53. Any recording in progress will not be affected. The MUTE message will flash in the display as a reminder. To restore normal audio, either press the Mute Button again, or adjust the volume. Turning off the AVR will also end muting.



Figure 53 – Mute Button

Tone Controls

You may boost or cut either the treble or the bass frequencies by up to 10dB.

Press the Tone Mode Button once. See Figure 54. This will indicate whether the tone controls are in or out of the circuitry. With the TONE IN message displayed, press the Tone Mode Button repeatedly to access TREBLE MODE and BASS MODE. Use the ▲/▼ Buttons to change the treble or bass settings, as desired.

OPERATION

If you wish to return the tone controls to 0, or "flat" response, press the ▲/▼ Buttons, until the TONE OUT message appears, which preserves any changes you have made to the bass or treble settings for later use. To reactivate your changes, the tone control must again be set to TONE IN. The display will return to normal a few seconds after your last command.



Figure 54 – Tone Button

You may also adjust the tone controls using the full-OSD menu system. Press the OSD Button on the remote to view the Master Menu. The cursor will be pointing to the INPUT SETUP line; press the OK Button to display that menu and view the current tone settings. If you wish to make any changes to the TONE, BASS or TREBLE settings, use the ▲/▼ Buttons to move the cursor to the line you wish to change. Once you have changed the setting using the ◀/▶ Buttons, simply move the cursor to a different line; it isn't necessary to press the OK Button to enter the new setting. When you have finished, either wait until the display times-out and disappears, press the OSD Button to clear the display, or move the cursor to the BACK TO MASTER MENU line if you wish to make other changes using the menu system.

NOTE: The AVR 154 does not have a conventional balance control. The speaker output level calibration process compensates for any characteristics of your room or speakers, and we recommend that you leave the settings as they are after you have completed Initial Setup. However, you may manually adjust the levels of the left and right channels – decreasing one and increasing the other by the same amount – using the Channel Adjust submenu, as described on page 32. This achieves the same effect as a balance control.

Headphones

Plug the 1/4" plug on a pair of headphones into the headphone jack on the front of the receiver for private listening. See Figure 55. The first time you use the headphones, the DOLBY H:BP message will be displayed, indicating that Dolby Headphone surround processing is in the bypass mode, which delivers a conventional 2-channel signal to the headphones.



Figure 55 – Headphone Jack

Press the Surround Select Button on the front panel, or the Dolby Button on the remote, to switch to Dolby Headphone virtual surround processing, indicated by the DOLBY H:DH message. Dolby Headphone delivers an enhanced sound field that emulates a 5.1-channel speaker system. No other surround modes are available for the headphones.

Source Selection

Press the front-panel Source Select Button to scroll through the sources. Each side of the button scrolls through the list in the opposite order. For direct access to the tuner, press the Tuner Band Button, which switches to the last-used band and frequency. See Figure 56. For direct access to any source, press its Input Selector on the remote (see Figure 37).



Figure 56 – Source Select and Tuner Band Buttons

The AVR 154 will switch to the audio and video inputs and surround mode assigned to the source. If you set the BASS MGR setting in the Speaker X-Over menu to INDEPENDENT, the AVR 154 will change the speaker size configuration to the one programmed for the source.

The source name appears in the upper line of the front-panel display. If you retitled the source, the new title will appear by itself. Otherwise, the audio input assigned to the source (analog or one of the digital audio inputs) will also be displayed. The surround mode is displayed on the lower line. The same information appears on screen in the semi-OSD, unless you have set the semi-OSD to OFF in the System Setup menu, as described in the Advanced Functions section.

Audio Input Selection

The AVR 154 is programmed at the factory to use the default audio inputs for each source, as indicated in Table A2 in the Appendix. To assign a digital audio input to a source (if you have not done so using the Input Setup menu during Initial Setup), press the Digital Button on the remote. The current audio input selection will flash in the display. Press the ▲/▼ Buttons to scroll through the audio inputs. When the desired input appears, press the OK Button to select it. See Figure 57.



Figure 57 – Digital Input Selection

If the Auto Poll feature is ON in the Input Setup menu, and if a digital audio input has been assigned to the source, the AVR 154 will first check the digital audio input for a signal. If a signal is present, the AVR 154 will select the digital audio input. If no signal is present, the AVR 154 will switch to the analog audio inputs for the source.

Video Input Selection

When a source is selected, the AVR 154 switches to a video input as follows:

OPERATION

The COMPONENT IN line of the Input Setup menu indicates which of the two component video inputs on the AVR 154 is assigned to each source. The default assignments are indicated in Table A2 in the Appendix. As shown, various sources share the component video input assignments, but only one source may be physically connected at a time.

You may reassign either component video input to another source if it is physically connected to that input, but there is no option to disable the component video inputs for any source. If a signal is present at the component video input assigned to that source, it will be selected. If your device is not using component video, make sure that other devices connected to the component video inputs are turned off.

If no signal is present at the component video input, then the S-video or composite video input for the source will be selected. It is not possible to reassign the S-video or composite video inputs to other sources.

For audio-only sources, such as the tuner or CD inputs, when no component video signal is present, the last-used analog video source, but not an HDMI source, will be selected.

6-Channel Direct Inputs

If you wish to hear audio through the 6-Channel Direct Inputs together with video, then connect your multichannel player to the Component Video 1 Inputs, and connect the player's 6-channel analog audio outputs to the 6-Channel Inputs on the AVR. Assign the component video inputs you selected to the 6-Channel Input source. The AVR will automatically select the correct component video and audio inputs when you select this source.

If you need to use composite or S-video for your multichannel player, e.g., if your video display does not have component video inputs, then use the video inputs for another source. Since the AVR automatically selects the last-used analog video inputs for audio sources, you would first select the source you connected the video cables to, and then the 6-Channel Inputs for the audio.

Example 1: Connect a non-HDMI-equipped DVD-Audio player to the AVR 154. You plan on playing a variety of discs using this player, including conventional DVDs and even CDs as well as multichannel discs. When playing DVDs and CDs, it is preferable to use a digital audio connection to obtain the best sound quality and the benefit of any digital surround formats contained on the DVD. However, when playing DVD-Audio discs, you will use the 6-channel analog audio connections. In addition, some of these discs contain video materials.

We recommend that you connect this player as follows:

- a) Connect the player's coaxial digital audio output to the Coaxial 1 Input on the AVR. This input is assigned by default to the DVD source.
- b) Connect the player's component video outputs to the Component Video 1 Inputs on the AVR, which are assigned by default to the DVD source. If your video display doesn't have component video inputs, then connect the player's composite or S-video output to the DVD's corresponding video input.

- c) Connect the player's 6-channel analog audio outputs to the AVR's 6-Channel Inputs and assign the Component Video 1 Inputs to this source using the Input Setup menu, as described in the Initial Setup section.

- d) Program the player's remote control codes into the DVD Input Selector.

When you wish to view a DVD, select the DVD source.

When you wish to listen to a DVD-Audio disc and view the menus and other still images on the disc, first select DVD, and then the 6-Channel Inputs as the source.

Example 2: Connect a multichannel disc player equipped with an HDMI output.

- a) Connect the player's coaxial digital audio output to the Coaxial 2 Input on the AVR. This input is assigned by default to the HDMI 1 source.
- b) Connect the player's HDMI output to the HDMI 1 source input, and connect the AVR's HDMI Output to your video display.
- c) Connect the player's 6-channel analog audio outputs to the AVR's 6-Channel Inputs.
- d) Connect the player's component video outputs to the Component Video 1 Inputs, as the AVR's 6-Channel Analog Audio Inputs cannot be used together with an HDMI input.
- e) Program the player's remote control codes into the HDMI 1 Input Selector.

When you wish to view a DVD, select the HDMI 1 source.

When you wish to play a multichannel disc, select the 6-Channel Inputs to select the audio signal and the analog component video signal.

To select the 6-Channel Inputs as the source, use either the Source Selector on the front panel or press the 6CH Input Selector on the remote. See Figures 37 and 39.

NOTE: The 6-Channel Inputs pass the incoming signals directly to the volume control, without digitizing or processing them. Therefore, configure bass management settings (i.e., speaker size, delay and output level) on your source device so that they match the settings you programmed during Initial Setup. Consult the owner's guide for your multichannel player for more information.

Using the Tuner

The AVR 154's built-in tuner may be selected in one of three ways (see Figure 58):

1. Press the Source Selector Button on the front panel repeatedly until the tuner is selected. The last-used band (AM or FM) will be active.
2. Press the Tuner Band Button (marked AM/FM). Press this button again to switch bands.

- Press the Tuner Input Selector (marked AM/FM) on the remote. Press this button again to switch bands.



Figure 58 – Tuner Input Selection

Radio stations may be selected in one of four ways (see Figure 59):

- If you know the frequency number, enter it directly by first pressing the Direct Button on the remote, and then using the Numeric Keys.
- After you have programmed Preset stations (see below), either enter the Preset number (1 through 30) using the remote or use the Preset Stations Button (front-panel or remote), to scroll through the list of presets.
- In Auto tuning mode, with each press of the Tuning Buttons (front-panel or remote) the AVR 154 will scan in the chosen direction until a station with acceptable signal strength is detected. Press the Tuning Button again to stop scanning.
- In Manual tuning mode, with each press of the Tuning Buttons the AVR 154 will tune the next frequency increment (0.1MHz for FM, or 10kHz for AM) in the selected direction. Press and hold the Tuning Button for faster scanning.



Figure 59 – Tuning a Station

Press the Tuning Mode Button (TUN-M on the remote) to switch between Auto and Manual tuning modes. See Figure 60. When an FM station has been tuned, pressing the Tuning Mode Button will switch between stereo and mono tuning, which may improve reception of weaker stations.



Figure 60 – Tuning Mode

To store a station in one of the 30 presets (see Figure 61):

- Tune the desired station.
- Press the Memory Button on the remote.
- Use the Numeric Keys to enter the desired preset number.



Figure 61 – Storing a Preset Station

Recording

Two-channel analog and digital audio signals, as well as composite and S-video signals, are normally available at the appropriate recording outputs. Thus, to make a recording, you need only make sure to connect your audio or video recorder to the appropriate output jacks, as described in the Installation section, insert blank media and make sure the recorder is turned on and recording while the source is playing.

NOTES:

- Analog audio signals are not converted to digital form, and digital audio signals are not converted to analog audio form. However, you may record a coaxial or optical digital audio source using either type of digital audio output.
- Only PCM digital audio signals are available for recording. Proprietary formats such as Dolby Digital and DTS may not be recorded using the digital audio connections. If the source is connected to the AVR using the analog audio connections, an analog recording may be made.
- HDMI and Component video sources are not available for recording.
- Please make certain that you are aware of any copyright restrictions on any material you record. Unauthorized duplication of copyrighted materials is prohibited by federal law.

AUX Input

Enjoy the full power and resolution of your Harman Kardon system, including a variety of analog surround modes, while listening to content stored on your portable device.

The Auxiliary Audio Input mini jack is provided on the AVR's rear panel for convenient connection of portable players, such as CD players and the iPod (iPod and cable not included). Purchase a stereo cable with a 1/8" plug on at least one end for connection to the Auxiliary Audio Input. Plug the other end of the cable into the portable device's headphone output, and operate the device using its own controls. You may also use a cable with separate left and right audio plugs at one end for connection to any component equipped with analog audio outputs.

No video connection is available with the AUX input. However, the AVR will use the last-selected analog video input when the AUX source is selected.

OPERATION

Selecting a Surround Mode

Surround mode selection can be as simple or sophisticated as your individual system and tastes. Feel free to experiment with the many available surround modes on the AVR 154, and you may find a few that become your favorites for certain sources or program types. Although more detailed information on surround modes may be found in the Advanced Functions section, it is easy to select any of the modes available at a given time:

To select a surround mode using the front-panel controls, press the Surround Mode Button repeatedly until the desired group of modes is selected: Logic 7, Dolby, DTS, DSP or Stereo. Then press the Surround Select Button repeatedly to select the desired mode within the group. See Figure 62.



Figure 62 – Select a Surround Mode (Front Panel)

To select a surround mode using the remote control, locate the button dedicated to the desired group of modes: Logic 7, Dolby Sur, DTS Sur, DTS Neo:6, Surr (DSP) or Stereo. Press that button repeatedly to select the desired mode. See Figure 63.



Figure 63 – Select a Surround Mode (Remote)

To select a surround mode using the full-OSD menu system, press the OSD Button to display the Master Menu. Navigate to the SURROUND SELECT line and press the OK Button to view the Surround Select menu (see Figure 64 on page 40). Each of the major surround mode groups is listed here. Select a group to access the MODE setting for selection of an individual mode. As explained in the Advanced Functions section, there are also some additional settings that may be made.

You are now ready to enjoy the best in home theater entertainment with your AVR 154. As you become more familiar with the receiver, you may wish to explore some of its advanced functions, which are described in the following section.

TROUBLESHOOTING GUIDE

SYMPTOM	CAUSE	SOLUTION
Unit does not function when Main Power Switch is pushed	<ul style="list-style-type: none"> No AC power 	<ul style="list-style-type: none"> Make certain AC power cord is plugged into a live outlet Check whether outlet is switch-controlled
Display lights, but no sound or picture	<ul style="list-style-type: none"> Intermittent input connections Mute is on Volume control is down Source device is turned off Incorrect audio/video inputs assigned to source Attempting to view HDMI video with another audio source input 	<ul style="list-style-type: none"> Make certain that all input and speaker connections are secure Press Mute Button Turn up volume control Turn on source and check its settings Use Input Setup menu to assign inputs The AVR 154 will select the last-used analog video input for an audio-only source, but will not select an HDMI video input; for multichannel disc players, use a component, composite or S-video connection
No sound from any speaker; light around power switch is red	<ul style="list-style-type: none"> Amplifier is in protection mode due to possible short Amplifier is in protection mode due to internal problems 	<ul style="list-style-type: none"> Check speaker wire connections for shorts at receiver and speaker ends Contact your local Harman Kardon service center
No sound from surround or center speakers	<ul style="list-style-type: none"> Incorrect surround mode Input is monaural Incorrect configuration Stereo or Mono program material 	<ul style="list-style-type: none"> Select a mode other than Stereo There is no surround information from mono sources Check speaker mode configuration The surround decoder may not create center- or rear-channel information from nonencoded programs
Unit does not respond to remote commands	<ul style="list-style-type: none"> Weak batteries in remote Wrong device selected Remote sensor is obscured 	<ul style="list-style-type: none"> Change remote batteries Press the AVR selector Make certain front-panel sensor is in line of sight of remote or connect an optional remote sensor
Intermittent buzzing in tuner	<ul style="list-style-type: none"> Local interference 	<ul style="list-style-type: none"> Move unit or antenna away from computers, fluorescent lights, motors or other electrical appliances
Letters flash in the channel indicator display and digital audio stops	<ul style="list-style-type: none"> Digital audio feed paused 	<ul style="list-style-type: none"> Resume play for DVD Check Digital Input selection

In addition to the items shown above, additional information on troubleshooting possible problems with your AVR 154, or installation-related issues, may be found in the list of "Frequently Asked Questions" which is located in the Product Support section of our Web site at www.harmankardon.com.

Erase a macro as follows:

1. Simultaneously press and hold the Mute Button and the Macro Button containing the macro until the LED flashes.
2. Press the Surround Button to erase the macro.

Resetting the Remote

To reset the remote to its factory defaults, simultaneously press and hold any Input Selector and the "0" Numeric Key. When the Program LED flashes in amber, enter the code "333". When the green LED goes out, the remote will have been fully reset.

Processor Reset

There may be instances when you wish to fully reset the AVR 154 to its factory defaults, or the unit may behave erratically after a power surge. To correct erratic behavior, first try turning the Master Power Switch off and unplugging the AC power cord for at least three minutes. Plug the cord back in and turn the receiver back on. If this doesn't help, try a system reset.

NOTES:

- A system reset erases all user configurations, including video resolution, speaker and level settings, and tuner presets. After a reset, you will need to reenter all of these settings.

To reset the AVR 154, place the receiver in Standby mode (press the front-panel Standby/On Switch so that the Power Indicator turns amber). Press and hold the front-panel Surround Mode Button for 5 to 10 seconds until the RESET message appears in the display.

Follow the directions in the owner's manual on page 32 to restore the picture if necessary.

Memory

If the AVR 154 is unplugged or experiences a power outage, it will retain user settings for up to four weeks.

1. Removing the Top Cabinet
Remove the Screws

①~⑬

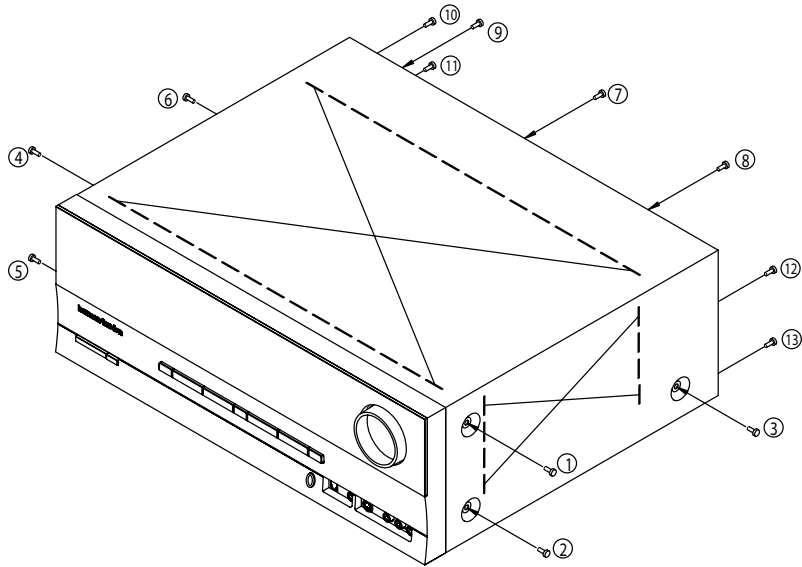

2. Removing the Front Panel
Remove the Screws

①~⑨

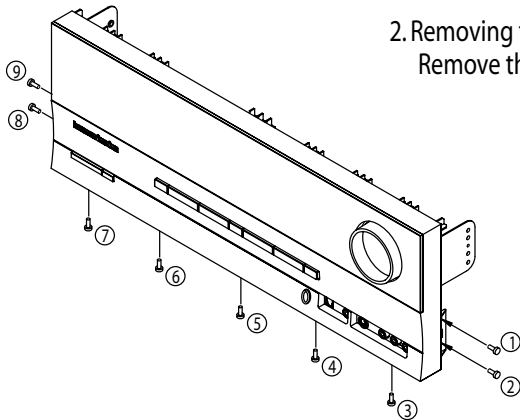

3. Removing the Rear Panel
Remove the Screws

①~⑳

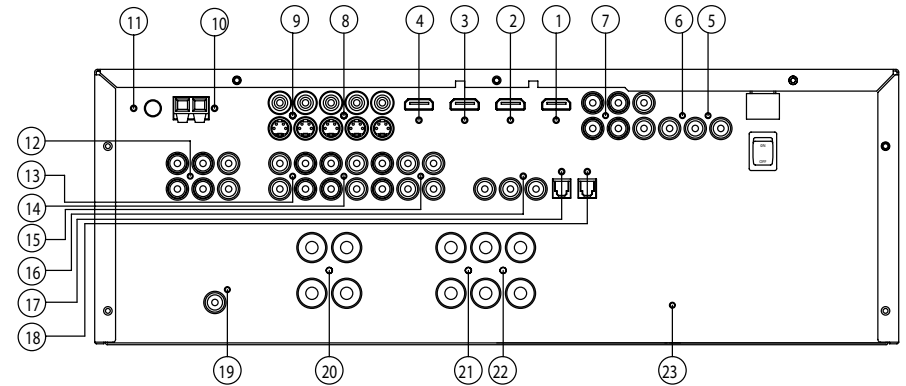

4. Removing the Main PCB
Remove the Screws

①~⑦

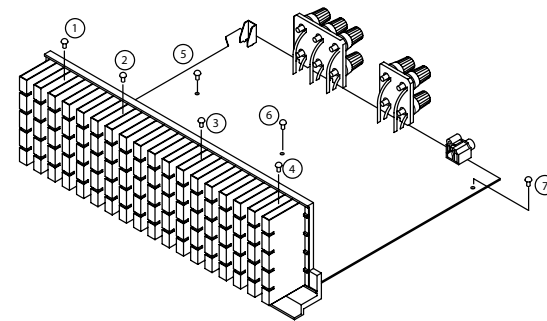

AVR154 EXPLODED VIEW

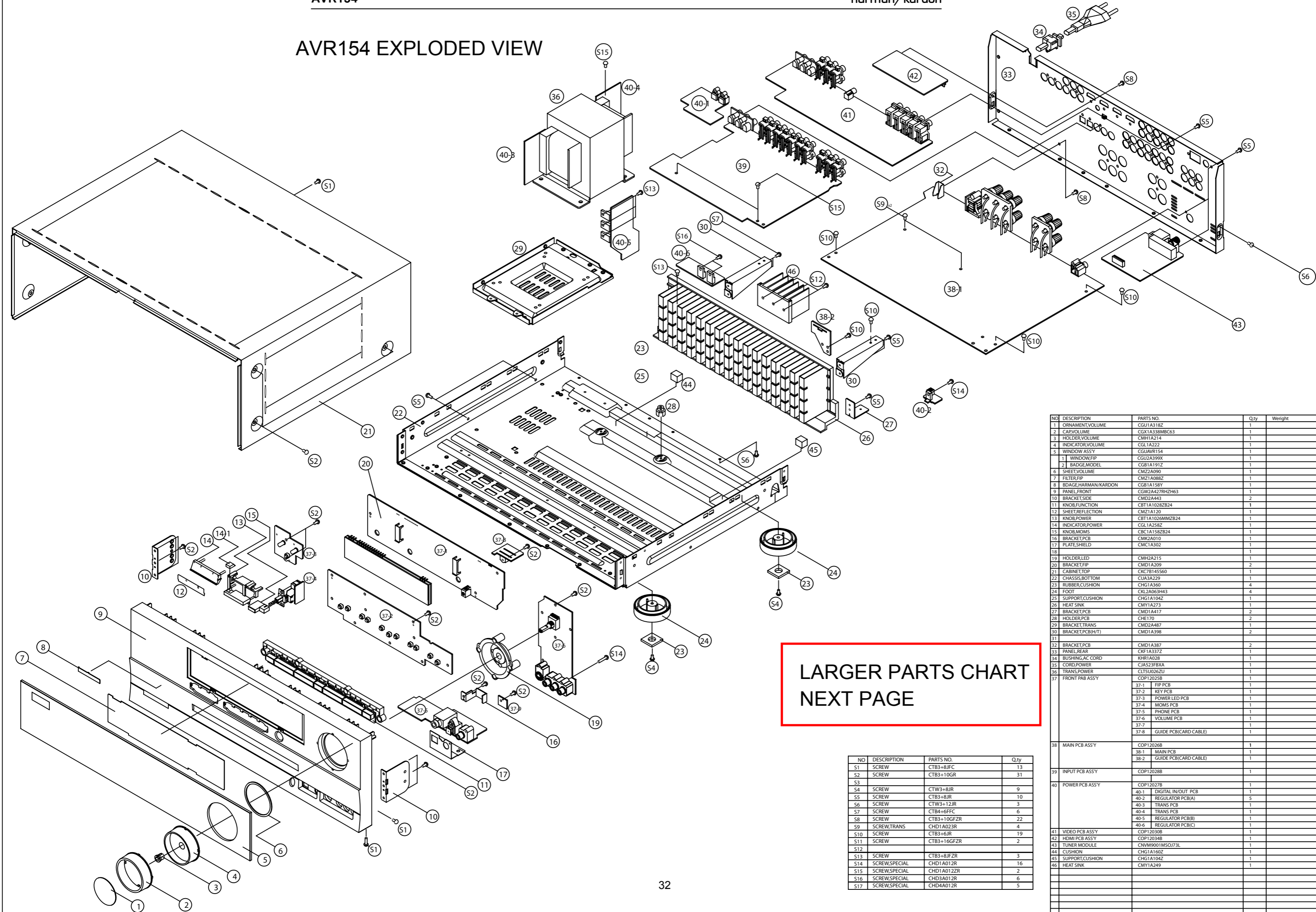

LARGER PARTS CHART
NEXT PAGE

NO	DESCRIPTION	PARTS NO.	Q.ty
S1	SCREW	CTB3+8JFC	13
S2	SCREW	CTB3+10GR	31
S3			
S4	SCREW	CTW3+8JR	9
S5	SCREW	CTB3+8JR	10
S6	SCREW	CTW3+12JR	3
S7	SCREW	CTB4+6FFC	6
S8	SCREW	CTB3+10GFZR	22
S9	SCREW,TRANS	CHD1A023R	4
S10	SCREW	CTB3+6JR	19
S11	SCREW	CTB3+16GFZR	2
S12			
S13	SCREW	CTB3+8JFZR	3
S14	SCREW,SPECIAL	CHD1A012R	16
S15	SCREW,SPECIAL	CHD1A012ZR	2
S16	SCREW,SPECIAL	CHD3A012R	6
S17	SCREW,SPECIAL	CHD4A012R	5

NO	DESCRIPTION	PARTS NO.	Q.ty	Weight
1	ORNAMENT,VOLUME	CGU1A318Z	1	
2	CAP,VOLUME	CGX1A338MBC63	1	
3	HOLDER,VOLUME	CMH1A214	1	
4	INDICATOR,VOLUME	CGL1A222	1	
5	WINDOW ASSY	CGUAVR154	1	
1	WINDOW,FIP	CGU2A399X	1	
2	BADGE,MODEL	CGB1A191Z	1	
6	SHEET,VOLUME	CMZ2A090	1	
7	FILTER,FIP	CMZ1A088Z	1	
8	BDAGE,HARMAN/KARDON	CGB1A158Y	1	
9	PANEL,FRONT	CGW2A427RHZH63	1	
10	BRACKET,SIDE	CMZ2A443	2	
11	KNOB,FUNCTION	CBT1A1028ZB24	1	
12	SHEET,REFLECTION	CMZ1A120	1	
13	KNOB,POWER	CBT1A1036MMZB24	1	
14	INDICATOR,POWER	CGL1A258Z	1	
15	KNOB,MOMS	CBT1A158ZB24	1	
16	BRACKET,PCB	CMK2A010	1	
17	PLATE,SHIELD	CMC1A302	1	
18				
19	HOLDER,LED	CMH2A215	1	
20	BRACKET,FIP	CMZ1A209	2	
21	CABINET, TOP	CKC7B145560	1	
22	CHASSIS,BOTTOM	CUA3A229	1	
23	RUBBER,CUSHION	CHG1A360	4	
24	FOOT	CKL2A063H43	4	
25	SUPPORT,CUSHION	CHG1A104Z	1	
26	HEAT SINK	CMY1A273	1	
27	BRACKET,PCB	CMZ1A417	2	
28	HOLDER,PCB	CHH170	2	
29	BRACKET,TRANS	CMZ2A487	1	
30	BRACKET,PCB(H/T)	CMZ1A398	2	
31				
32	BRACKET,PCB	CMZ1A387	2	
33	PANEL,REAR	CKF1A337Z	1	
34	BUSHING,AC CORD	KHR1A028	1	
35	CORD,POWER	CJA523FBXA	1	
36	TRANS,POWER	CLTSU026ZU	1	
37	FRONT PAB ASSY	COP12025B	1	
		37-1 FIP PCB	1	
		37-2 KEY PCB	1	
		37-3 POWER LED PCB	1	
		37-4 MOMS PCB	1	
		37-5 PHONE PCB	1	
		37-6 VOLUME PCB	1	
		37-7	1	
		37-8 GUIDE PCB(CARD CABLE)	1	
38	MAIN PCB ASSY	COP12026B	1	
		38-1 MAIN PCB	1	
		38-2 GUIDE PCB(CARD CABLE)	1	
39	INPUT PCB ASSY	COP12028B	1	
40	POWER PCB ASSY	COP12027B	1	
		40-1 DIGITAL IN/OUT PCB	1	
		40-2 REGULATOR PCB(A)	5	
		40-3 TRANS PCB	1	
		40-4 TRBA PCB	1	
		40-5 REGULATOR PCB(B)	1	
		40-6 REGULATOR PCB(C)	1	
41	VIDEO PCB ASSY	COP12030B	1	
42	HDMI PCB ASSY	COP12034B	1	
43	TUNER MODULE	CNMV9001MSO73L	1	
44	CUSHION	CHG1A160Z	1	
45	SUPPORT,CUSHION	CHG1A104Z	1	
46	HEAT SINK	CMY1A249	1	

NO	DESCRIPTION	PARTS NO.	Q,ty
1	ORNAMENT,VOLUME	CGU1A318Z	1
2	CAP,VOLUME	CGX1A338MBC63	1
3	HOLDER,VOLUME	CMH1A214	1
4	INDICATOR,VOLUME	CGL1A222	1
5	WINDOW ASS'Y	CGUAVR154	1
	1 WINDOW,FIP	CGU2A399X	1
	2 BADGE,MODEL	CGB1A191Z	1
6	SHEET,VOLUME	CMZ2A090	1
7	FILTER,FIP	CMZ1A088Z	1
8	BADGE,HARMAN/KARDON	CGB1A158Y	1
9	PANEL,FRONT	CGW2A427RHZH63	1
10	BRACKET,SIDE	CMD2A443	2
11	KNOB,FUNCTION	CBT1A1028ZB24	1
12	SHEET,REFLECTION	CMZ1A120	1
13	KNOB,POWER	CBT1A1026MMZB24	1
14	INDICATOR,POWER	CGL1A258Z	1
15	KNOB,MOMS	CBC1A158ZB24	1
16	BRACKET,PCB	CMK2A010	1
17	PLATE,SHIELD	CMC1A302	1
18			1
19	HOLDER,LED	CMH2A215	1
20	BRACKET,FIP	CMD1A209	2
21	CABINET,TOP	CKC7B145S60	1
22	CHASSIS,BOTTOM	CUA3A229	1
23	RUBBER,CUSHION	CHG1A360	4
24	FOOT	CKL2A063H43	4
25	SUPPORT,CUSHION	CHG1A104Z	1
26	HEAT SINK	CMY1A273	1
27	BRACKET,PCB	CMD1A417	2
28	HOLDER,PCB	CHE170	2
29	BRACKET,TRANS	CMD2A487	1
30	BRACKET,PCB(H/T)	CMD1A398	2
31			
32	BRACKET,PCB	CMD1A387	2
33	PANEL,REAR	CKF1A337Z	1
34	BUSHING,AC CORD	KHR1A028	1
35	CORD,POWER	CJA523FBXA	1
36	TRANS,POWER	CLT5U026ZU	1
37	FRONT PCB ASS'Y		1
	37-1 FIP PCB		1
	37-2 KEY PCB		1
	37-3 POWER LED PCB		1
	37-4 MOMS PCB		1
	37-5 PHONE PCB		1
	37-6 VOLUME PCB		1
	37-7		1
	37-8 GUIDE PCB(CARD CABLE)		1
38	MAIN PCB ASS'Y		1
	38-1 MAIN PCB		1
	38-2 GUIDE PCB(CARD CABLE)		1
39	INPUT PCB ASS'Y		1
40	POWER PCB ASS'Y		1
	40-1 DIGITAL IN/OUT PCB		1
	40-2 REGULATOR PCB(A)		5
	40-3 TRANS PCB		1
	40-4 TRANS PCB		1
	40-5 REGULATOR PCB(B)		1
	40-6 REGULATOR PCB(C)		1
41	VIDEO PCB ASS'Y		1
42	HDMI PCB ASS'Y		1
43	TUNER MODULE	CNVM9001MSOJ73L	1
44	CUSHION	CHG1A160Z	1
45	SUPPORT,CUSHION	CHG1A104Z	1
46	HEAT SINK	CMY1A249	1

AMPLIFIER SECTION BIAS ADJUSTMENT

Measurement condition

.No input signal or volume position is minimum.

Standard value

.Ideal current = 48mA ($\pm 5\%$)

.Ideal DC Voltage = 25.92mV ($\pm 5\%$)

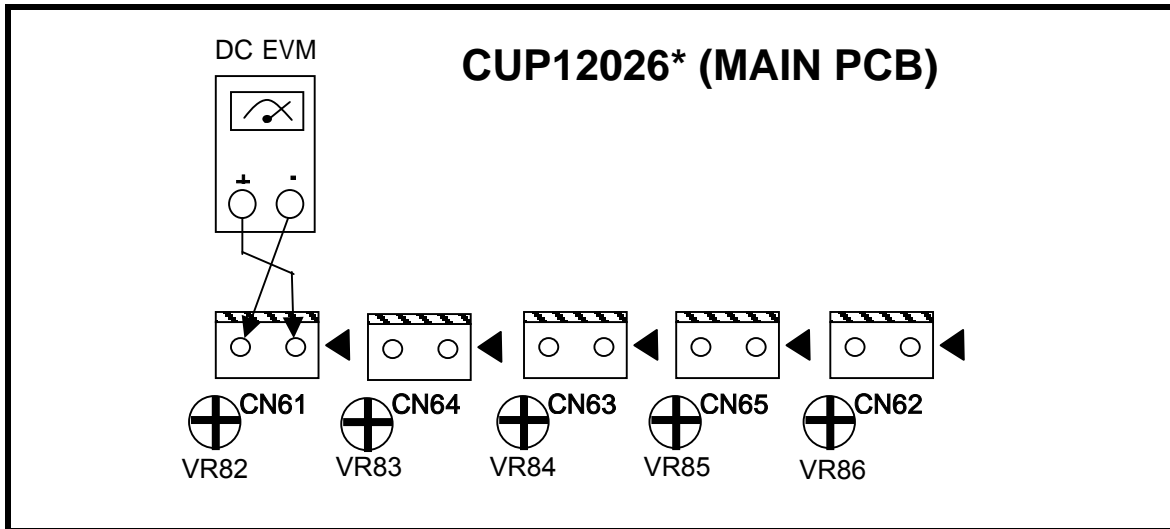

DC VOLTMETER ; Connect to

CN61(CEN),CN64(SR),CN63(FL),CN65(SBL/SL(AVR154, 155)),CN62(FR)

NO.	Channel	Adjust for	Adjustment
1	Front Left	25.92mV ($\pm 5\%$)	CN63
2	Front Right	25.92mV ($\pm 5\%$)	CN62
3	Center	25.92mV ($\pm 5\%$)	CN61
4	Surround Left	25.92mV ($\pm 5\%$)	CN65
5	Surround Right	25.92mV ($\pm 5\%$)	CN64

AVR154 BLOCK DIAGRAM

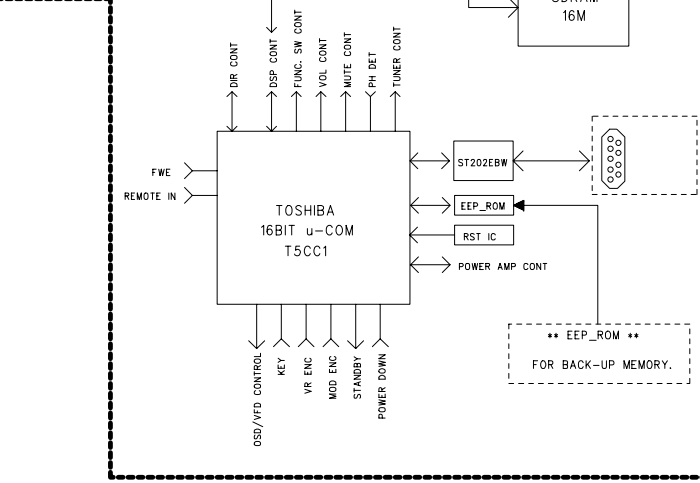
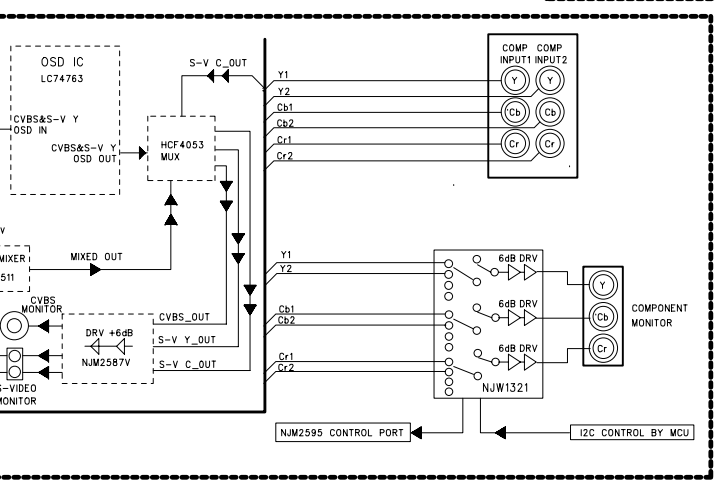
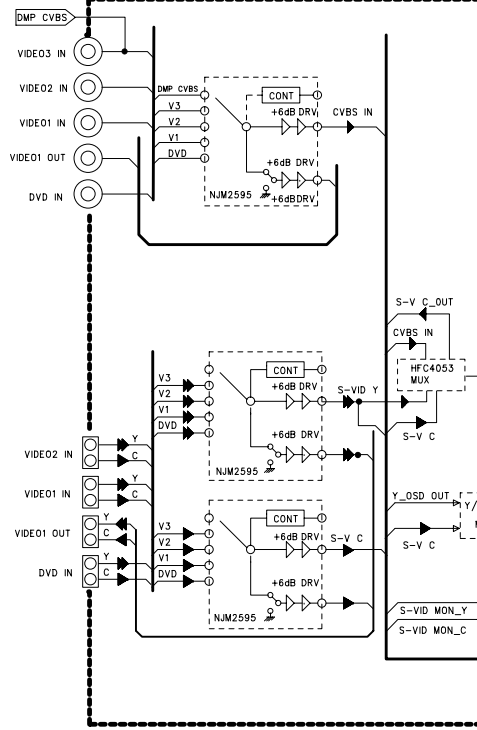
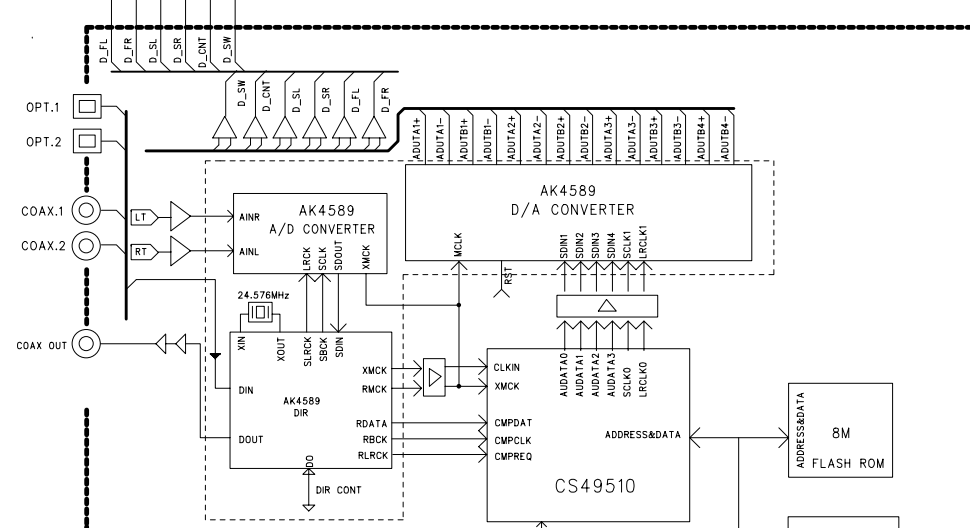
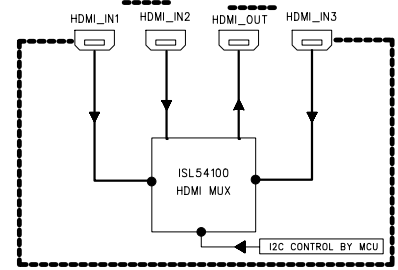
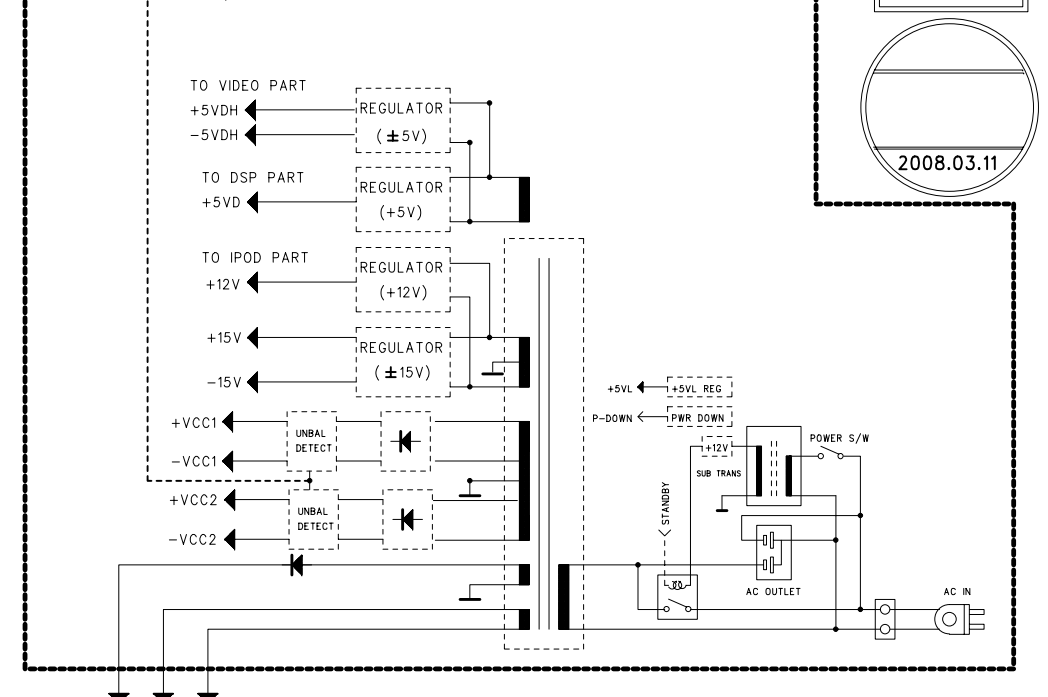
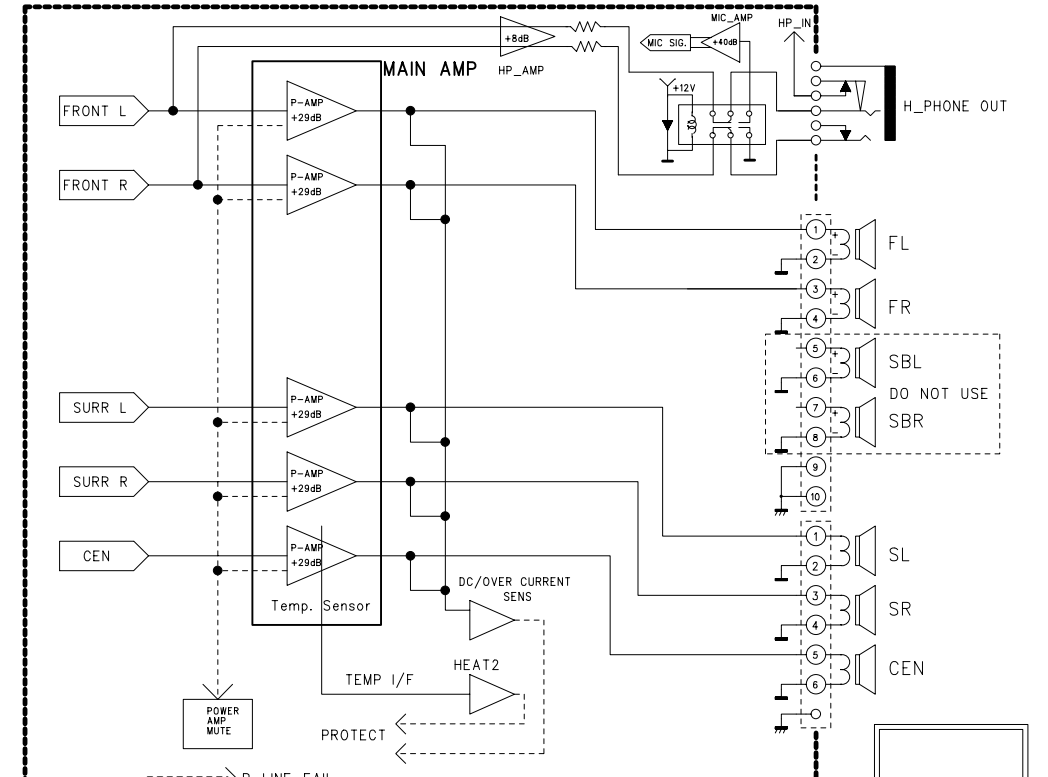
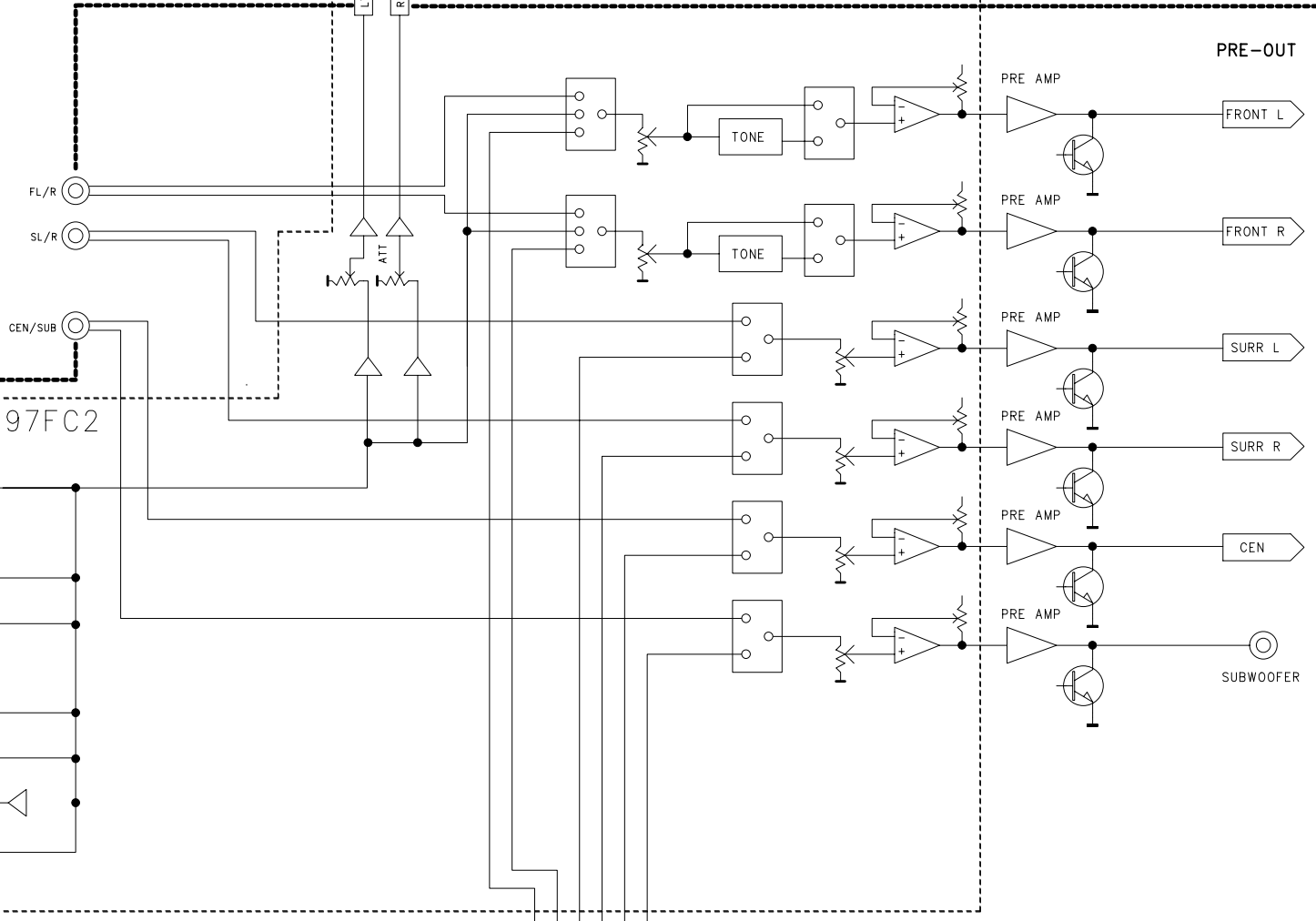
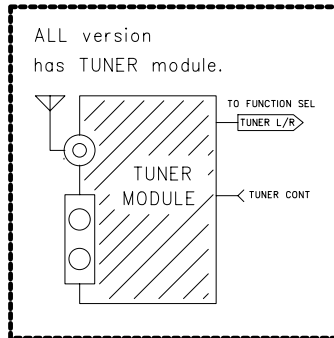

REVISION	2	4	6
1	3	5	7
MODEL	1		
DESIGN	CHECK	APPROVE	DRAWING NO
J.T.BAEK		K.S.WEY	BLOCK DIAGRAM
	08.03.11	08.03.11	

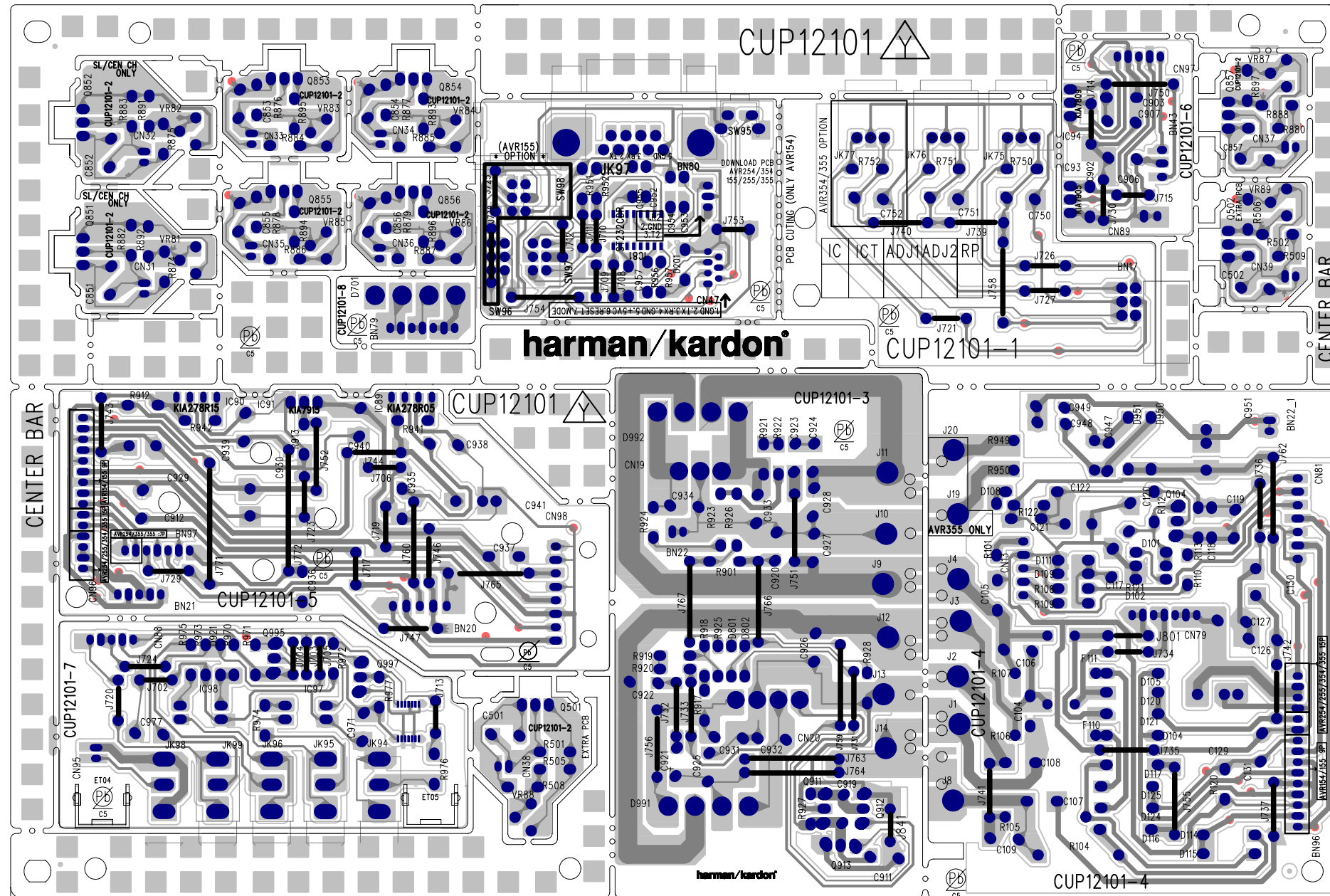

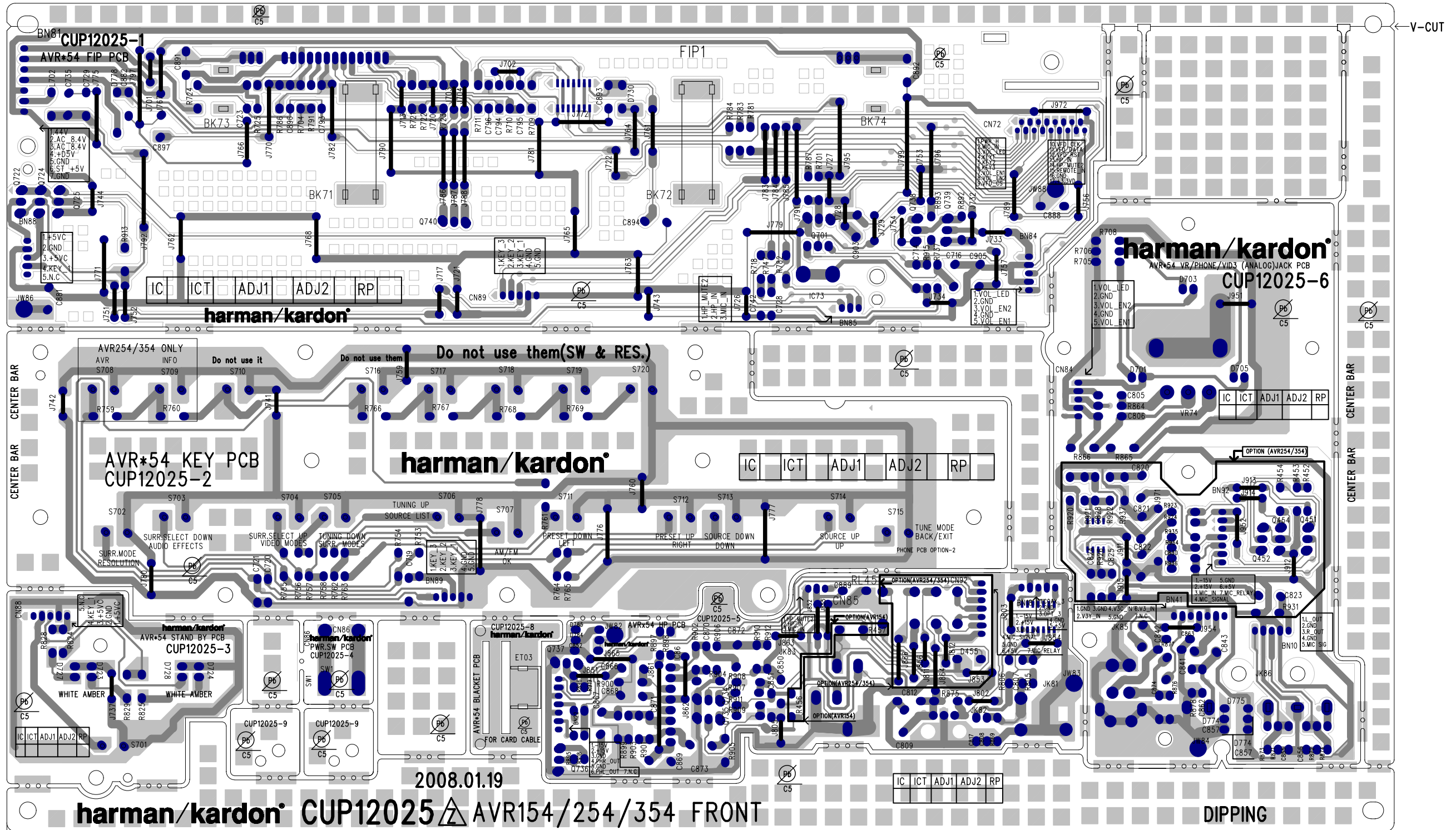

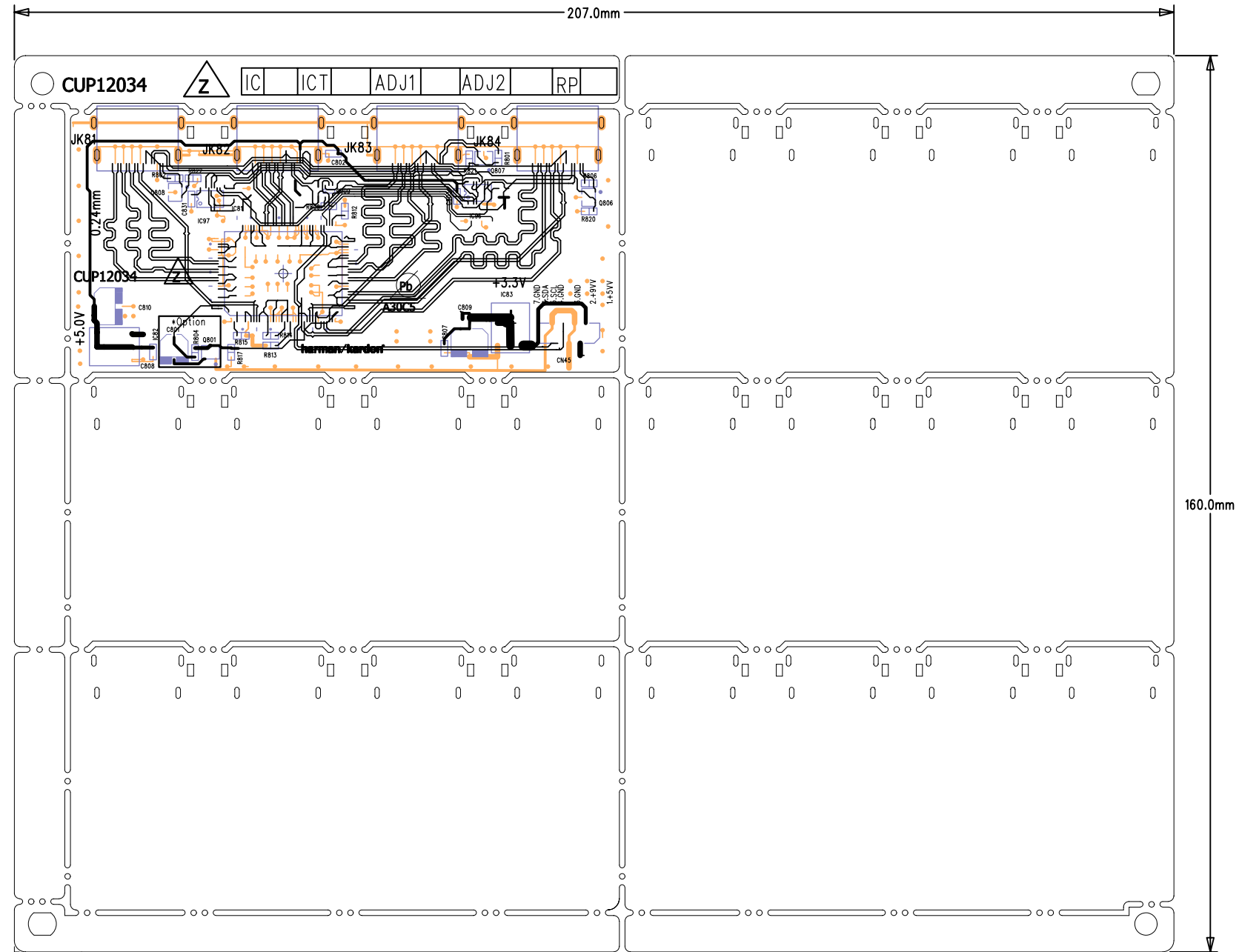

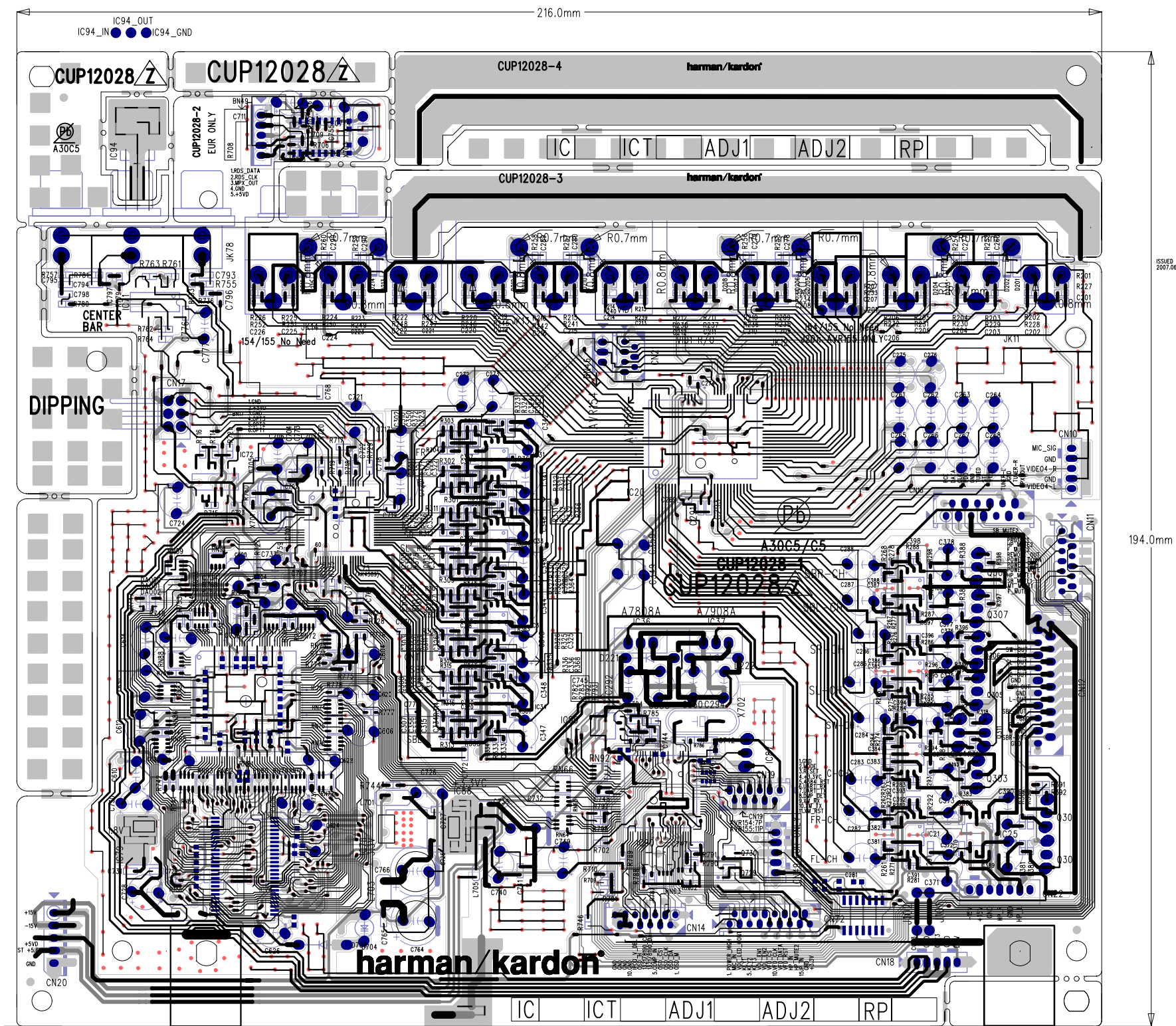

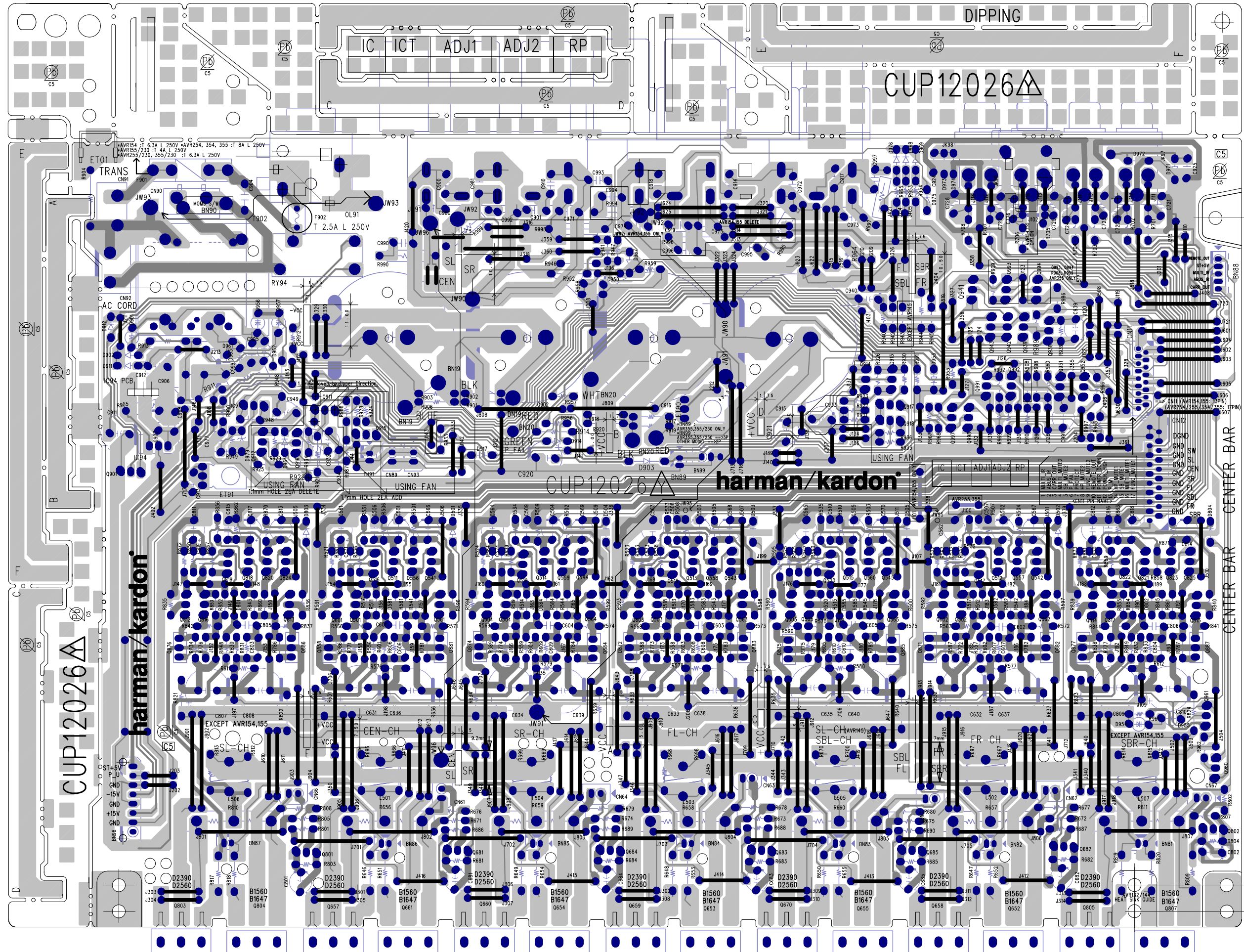

AVR154 Electrical Parts List					
Ref. Designator	Part Number	Description		Qty	
FRONT PCB ASSY		CUP12025			
<i>Capacitors</i>					
C714	CCBS1H151KBT	CAP , CERAMIC	150UF 50V K	1	EA
C716	CCEA1AH331T	CAP , ELECT	330UF 10V	1	EA
C719	CCBS1H102KBT	CAP , CERAMIC	1000PF 50V K	1	EA
C720	CCBS1H102KBT	CAP , CERAMIC	1000PF 50V K	1	EA
C721	CCBS1H102KBT	CAP , CERAMIC	1000PF 50V K	1	EA
C723	CCBS1H104ZFT	CAP , CERAMIC	0.1UF 50V Z	1	EA
C728	CCBS1H104ZFT	CAP , CERAMIC	0.1UF 50V Z	1	EA
C729	CCBS1H473ZFT	CAP , CERAMIC	0.047UF 50V Z	1	EA
C735	CCEA1CKS100T	CAP , ELECT	10UF 16V	1	EA
C742	CCBS1H223ZFT	CAP , CERAMIC	0.022UF 50V Z	1	EA
C793	CCBS1H104ZFT	CAP , CERAMIC	0.1UF 50V Z	1	EA
C794	CCBS1C222MXT	CAP , CERAMIC	2200PF 16V	1	EA
C795	CCBS1H102KBT	CAP , CERAMIC	1000PF 50V K	1	EA
C796	CCBS1H102KBT	CAP , CERAMIC	1000PF 50V K	1	EA
C805	CCBS1H223ZFT	CAP , CERAMIC	0.022UF 50V Z	1	EA
C806	CCBS1H223ZFT	CAP , CERAMIC	0.022UF 50V Z	1	EA
C807	CCBS1H104ZFT	CAP , CERAMIC	0.1UF 50V Z	1	EA
C808	CCBS1H181KBT	CAP , CERAMIC	180PF 50V	1	EA
C809	CCEA1AH471T	CAP , ELECT	470UF 10V	1	EA
C812	CCBS1H104ZFT	CAP , CERAMIC	0.1UF 50V Z	1	EA
C817	CCBS1H100JCT	CAP , CERAMIC	10PF 50V	1	EA
C841	CCEA1HH100T	CAP , ELECT	10UF 50V	1	EA
C842	CCEA1HH100T	CAP , ELECT	10UF 50V	1	EA
C843	CCEA1HH100T	CAP , ELECT	10UF 50V	1	EA
C850	CCBS1H471KBT	CAP , CERAMIC	470PF 50V	1	EA
C851	CCBS1H471KBT	CAP , CERAMIC	470PF 50V	1	EA
C852	CCBS1H104ZFT	CAP , CERAMIC	0.1UF 50V Z	1	EA
C855	CCBS1H101KBT	CAP , CERAMIC	100PF 50V K	1	EA
C856	CCBS1H101KBT	CAP , CERAMIC	100PF 50V K	1	EA
C857	CCBS1H104ZFT	CAP , CERAMIC	0.1UF 50V Z	1	EA
C862	CCBS1H101KBT	CAP , CERAMIC	100PF 50V K	1	EA
C863	CCBS1H101KBT	CAP , CERAMIC	100PF 50V K	1	EA
C866	CCEA1HKS100T	CAP , ELECT	10UF 50V SMALL SIZE	1	EA
C867	CCEA1HKS100T	CAP , ELECT	10UF 50V SMALL SIZE	1	EA
C868	CCEA1EKS470T	CAP , ELECT	47UF 25V	1	EA
C869	CCEA1EKS470T	CAP , ELECT	47UF 25V	1	EA
C870	CCBS1H681KBT	CAP , CERAMIC	680PF 50V K	1	EA
C871	CCBS1H681KBT	CAP , CERAMIC	680PF 50V K	1	EA
C872	CCEA1CH331T	CAP , ELECT	330UF 16V	1	EA
C873	CCEA1CH331T	CAP , ELECT	330UF 16V	1	EA
C874	CCBS1H101KBT	CAP , CERAMIC	100PF 50V K	1	EA
C882	CCBS1H104ZFT	CAP , CERAMIC	0.1UF 50V Z	1	EA
C888	CCBS1H104ZFT	CAP , CERAMIC	0.1UF 50V Z	1	EA
C889	CCBS1H104ZFT	CAP , CERAMIC	0.1UF 50V Z	1	EA
C891	CCBS1H223ZFT	CAP , CERAMIC	0.022UF 50V Z	1	EA
C892	CCBS1H223ZFT	CAP , CERAMIC	0.022UF 50V Z	1	EA
C893	CCBS1H223ZFT	CAP , CERAMIC	0.022UF 50V Z	1	EA
C894	CCEA1CKS100T	CAP , ELECT	10UF 16V	1	EA
C896	CCBS1H223ZFT	CAP , CERAMIC	0.1UF 50V Z	1	EA
C897	CCEA1AH471T	CAP , ELECT	470UF 10V	1	EA
C903	CCEA1HKS2R2T	CAP , ELECT	2.2UF 50V SMALL SIZE	1	EA
C905	CCEA1HKS2R2T	CAP , ELECT	2.2UF 50V SMALL SIZE	1	EA
<i>Semiconductors</i>					
D730	USE BUSS WIRE	WIRE , COPPER		1	EA
D774	CVD1SS133MT	DIODE	1SS133	1	EA

Ref. Designator	Part Number	Description		Qty	
FRONT PCB ASSY		CUP12025			
D775	CVD1SS133MT	DIODE	1SS133	1	EA
D784	CVD1SS133MT	DIODE	1SS133	1	EA
D785	CVD1SS133MT	DIODE	1SS133	1	EA
Q701	HVTKRC107MT	TRANSISTOR NPN	KRC107M	1	EA
Q722	HVTKRA107MT	TRANSISTOR PNP	KRA107M	1	EA
Q724	HVTKRC107MT	TRANSISTOR NPN	KRC107M	1	EA
Q725	HVTKRC107MT	TRANSISTOR NPN	KRC107M	1	EA
Q734	HVTKTC2874BT	TRANSISTOR , MUTE NPN	KTC2874B	1	EA
Q735	HVTKTC2874BT	TRANSISTOR , MUTE NPN	KTC2874B	1	EA
Q736	HVTKTC2874BT	TRANSISTOR , MUTE NPN	KTC2874B	1	EA
Q737	HVTKTC2874BT	TRANSISTOR , MUTE NPN	KTC2874B	1	EA
Q738	HVTKRC107MT	TRANSISTOR NPN	KRC107M	1	EA
Q739	HVTKTA1271YT	TRANSISTOR PNP	KTA1271Y	1	EA
Q740	HVTKTC3200GRT	TRANSISTOR NPN	KTC3200GR	1	EA
D778	HVD1N5819T	DIODE , SCHOTTKY	1N5819	1	EA
D786	CVD1SS133MT	DIODE	1SS133	1	EA
D787	CVD1SS133MT	DIODE	1SS133	1	EA
IC73	HRVJNL34H380A	SENSOR , REMOCON	SENSOR	1	EA
IC75	HVI74ACT04MTR	I.C , HEX INVERTER	JRC(74ACT04MTR)	1	EA
IC76	HVI74HCU04AFNG	I.C , INVERTER	FAIRCHILD(74HCU04AFNG)	1	EA
IC86	HVINJM4556AL	I.C , DUAL OP AMP	JRC(NJM4556AL)	1	EA
D701	CVD1L0345W31BOCT20	L.E.D , WHITE	LED	1	EA
D703	CVD1L0345W31BOCT20	L.E.D , WHITE	LED	1	EA
D705	CVD1L0345W31BOCT20	L.E.D , WHITE	LED	1	EA
D723	CVD30ASOGCAA-S7	L.E.D , ORANGE	LED	1	EA
D724	CVD30ASOGCAA-S7	L.E.D , ORANGE	LED	1	EA
D727	CVD1L0345W31BOCT20	L.E.D , WHITE	LED	1	EA
D728	CVD1L0345W31BOCT20	L.E.D , WHITE	LED	1	EA
<i>Resistors</i>					
R456	USE BUSS WIRE	WIRE , COPPER		1	EA
R457	USE BUSS WIRE	WIRE , COPPER		1	EA
R701	CRD20TJ103T	RES , CARBON	10K OHM 1/5W J	1	EA
R704	CRD20TJ100T	RES , CARBON	10 OHM 1/5W J	1	EA
R705	CRD20TJ101T	RES , CARBON	100 OHM 1/5W J	1	EA
R706	CRD20TJ101T	RES , CARBON	100 OHM 1/5W J	1	EA
R708	CRD20TJ101T	RES , CARBON	100 OHM 1/5W J	1	EA
R709	CRD20TJ470T	RES , CARBON	47 OHM 1/5W J	1	EA
R710	CRD20TJ470T	RES , CARBON	47 OHM 1/5W J	1	EA
R711	CRD20TJ470T	RES , CARBON	47 OHM 1/5W J	1	EA
R718	CRD20TJ222T	RES , CARBON	2.2K OHM 1/5W J	1	EA
R721	CRD20TJ101T	RES , CARBON	100 OHM 1/5W J	1	EA
R722	CRD20TJ104T	RES , CARBON	100K OHM 1/5W J	1	EA
R723	CRD20TJ393T	RES , CARBON	39K OHM 1/5W J	1	EA
R724	CRD20TJ100T	RES , CARBON	10 OHM 1/5W J	1	EA
R725	CRD20TJ100T	RES , CARBON	10 OHM 1/5W J	1	EA
R737	CRD20TJ100T	RES , CARBON	10 OHM 1/5W J	1	EA
R747	CRD20TJ103T	RES , CARBON	10K OHM 1/5W J	1	EA
R753	CRD20TF1001T	RES , CARBON	1K /1/5W /F	1	EA
R754	CRD20TF1501T	RES , CARBON	1.5K /1/5W /F	1	EA
R755	CRD20TF1801T	RES , CARBON	1.8K /1/5W /F	1	EA
R756	CRD20TF2701T	RES , CARBON	2.7K /1/5W/F	1	EA
R757	CRD20TF3301T	RES , CARBON	3.3K /1/5W/F	1	EA
R758	CRD20TF5601T	RES , CARBON	5.6K /1/5W/F	1	EA
R759	CRD20TF1001T	RES , CARBON	1K /1/5W /F	1	EA
R760	CRD20TF1501T	RES , CARBON	1.5K /1/5W /F	1	EA
R761	CRD20TF1801T	RES , CARBON	1.8K /1/5W /F	1	EA
R762	CRD20TF2701T	RES , CARBON	2.7K /1/5W/F	1	EA
R763	CRD20TF3301T	RES , CARBON	3.3K /1/5W/F	1	EA

Ref. Designator	Part Number	Description		Qty	
FRONT PCB ASSY		CUP12025			
R764	CRD20TF5601T	RES , CARBON	5.6K /1/5W/F	1	EA
R765	CRD20TF7501T	RES , CARBON	7.5K /1/5W/F	1	EA
R781	CRD20TJ102T	RES , CARBON	1K OHM 1/5W J	1	EA
R783	CRD20TJ102T	RES , CARBON	1K OHM 1/5W J	1	EA
R784	CRD20TJ102T	RES , CARBON	1K OHM 1/5W J	1	EA
R786	CRD20TJ152T	RES , CARBON	1.5K OHM 1/5W J	1	EA
R787	CRD20TJ101T	RES , CARBON	100 OHM 1/5W J	1	EA
R791	CRD20TJ123T	RES , CARBON	12K OHM 1/5W J	1	EA
R805	CRD20TJ104T	RES , CARBON	100K OHM 1/5W J	1	EA
R806	CRD20TJ472T	RES , CARBON	4.7K OHM 1/5W J	1	EA
R824	CRD20TJ221T	RES , CARBON	220 OHM 1/5W J	1	EA
R825	CRD20TJ331T	RES , CARBON	330 OHM 1/5W J	1	EA
R828	CRD20TJ221T	RES , CARBON	220 OHM 1/5W J	1	EA
R829	CRD20TJ331T	RES , CARBON	330 OHM 1/5W J	1	EA
R864	CRD20TJ272T	RES , CARBON	2.7K OHM 1/5W J	1	EA
R865	CRD20TJ101T	RES , CARBON	100 OHM 1/5W J	1	EA
R866	CRD20TJ272T	RES , CARBON	2.7K OHM 1/5W J	1	EA
R869	CRD20TJ750T	RES , CARBON	75 OHM 1/5W J	1	EA
R871	CRD20TJ104T	RES , CARBON	100K OHM 1/5W J	1	EA
R872	CRD20TJ104T	RES , CARBON	100K OHM 1/5W J	1	EA
R873	CRD20TJ471T	RES , CARBON	470 OHM 1/5W J	1	EA
R874	CRD20TJ471T	RES , CARBON	470 OHM 1/5W J	1	EA
R875	CRD20TJ103T	RES , CARBON	10K OHM 1/5W J	1	EA
R876	CRD20TJ750T	RES , CARBON	75 OHM 1/5W J	1	EA
R877	CRD20TJ750T	RES , CARBON	75 OHM 1/5W J	1	EA
R878	CRD20TJ750T	RES , CARBON	75 OHM 1/5W J	1	EA
R892	CRD20TJ222T	RES , CARBON	2.2K OHM 1/5W J	1	EA
R893	CRD20TJ333T	RES , CARBON	33K OHM 1/5W J	1	EA
R895	CRD20TJ101T	RES , CARBON	100 OHM 1/5W J	1	EA
R896	CRD20TJ101T	RES , CARBON	100 OHM 1/5W J	1	EA
R897	CRD20TJ101T	RES , CARBON	100 OHM 1/5W J	1	EA
R898	CRD20TJ101T	RES , CARBON	100 OHM 1/5W J	1	EA
R899	CRD20TJ104T	RES , CARBON	100K OHM 1/5W J	1	EA
R900	CRD20TJ104T	RES , CARBON	100K OHM 1/5W J	1	EA
R901	CRD20TJ152T	RES , CARBON	1.5K OHM 1/5W J	1	EA
R902	CRD20TJ152T	RES , CARBON	1.5K OHM 1/5W J	1	EA
R903	CRD20TJ102T	RES , CARBON	1K OHM 1/5W J	1	EA
R904	CRD20TJ102T	RES , CARBON	1K OHM 1/5W J	1	EA
R905	CRD20TJ104T	RES , CARBON	100K OHM 1/5W J	1	EA
R906	CRD20TJ104T	RES , CARBON	100K OHM 1/5W J	1	EA
R907	CRD20TJ472T	RES , CARBON	4.7K OHM 1/5W J	1	EA
R908	CRD20TJ472T	RES , CARBON	4.7K OHM 1/5W J	1	EA
R909	CRD20TJ221T	RES , CARBON	220 OHM 1/5W J	1	EA
R910	CRD20TJ221T	RES , CARBON	220 OHM 1/5W J	1	EA
R911	CRD20TJ221T	RES , CARBON	220 OHM 1/5W J	1	EA
R912	CRD20TJ221T	RES , CARBON	220 OHM 1/5W J	1	EA
R913	CRD20TJ102T	RES , CARBON	1K OHM 1/5W J	1	EA
R915	CRD20TJ473T	RES , CARBON	47K OHM 1/5W J	1	EA
R918	CRD20TJ472T	RES , CARBON	4.7K OHM 1/5W J	1	EA
R919	CRD20TJ472T	RES , CARBON	4.7K OHM 1/5W J	1	EA
VR74	CSR2A037Z	ENCODER	ENCODER	1	EA
<i>Miscellaneous</i>					
S701	HST1A020ZT	SW , TACT	TACT SWITCH	1	EA
S702	HST1A020ZT	SW , TACT	TACT SWITCH	1	EA
S703	HST1A020ZT	SW , TACT	TACT SWITCH	1	EA
S704	HST1A020ZT	SW , TACT	TACT SWITCH	1	EA
S705	HST1A020ZT	SW , TACT	TACT SWITCH	1	EA
S706	HST1A020ZT	SW , TACT	TACT SWITCH	1	EA
S707	HST1A020ZT	SW , TACT	TACT SWITCH	1	EA

Ref. Designator	Part Number	Description		Qty	
FRONT PCB ASSY		CUP12025			
S711	HST1A020ZT	SW , TACT	TACT SWITCH	1	EA
S712	HST1A020ZT	SW , TACT	TACT SWITCH	1	EA
S713	HST1A020ZT	SW , TACT	TACT SWITCH	1	EA
S714	HST1A020ZT	SW , TACT	TACT SWITCH	1	EA
S715	HST1A020ZT	SW , TACT	TACT SWITCH	1	EA
BK71	CMD1A209	BRACKET , FLT	A4-92-1739	1	EA
BK72	CMD1A209	BRACKET , FLT	A4-92-1739	1	EA
BN10	CWZAVR155BN10	SHIELD WIRE ASS'Y(5P, 2MM, 350MM)	BRACKET	1	EA
BN18	CWZAVR155BN18	SHIELD WIRE ASS'Y (5P, 350MM, 2MM)	BRACKET	1	EA
BN22	CWZAVR155BN22	WIRE ASS'Y(7P, 2MM, 500MM)	WIRE	1	EA
BN41	CWZAVR155BN41	SHIELD WIRE ASS'Y(7P, 2MM, 500MM)	WIRE	1	EA
BN81	CWB1C907200BM	WIRE ASS'Y	WIRE	1	EA
BN84	CWB2B905080EN	WIRE ASS'Y	WIRE	1	EA
BN85	CWB2B903100EW	WIRE ASS'Y	WIRE	1	EA
BN88	CWB2B905100EN	WIRE ASS'Y	WIRE	1	EA
BN89	CWB2B905100EN	WIRE ASS'Y	WIRE	1	EA
CN72	CJP17GA117ZY	WAFER	WAFER	1	EA
CN84	CJP05GB46ZY	WAFER	WAFER	1	EA
CN85	CJP03GA19ZY	WAFER , STRAIGHT(3PIN)	WAFER	1	EA
CN86	CJP02GA89ZM	WAFER	WAFER	1	EA
CN88	CJP05GB46ZY	WAFER	WAFER	1	EA
CN89	CJP05GB46ZY	WAFER	WAFER	1	EA
ET03	CMD1A629	BRACKET , PCB	BRACKET	1	EA
FIP1	CFL17BT031GINK	F.I.P , AVR355	FIP(FUTABA)	1	EA
JK81	CJJ4M041Y	JACK , BOARD (COAX)	JACK	1	EA
JK82	HJSTORX177L	MODULE , OPTICAL(RX)	TORX177L	1	EA
JK83	CJJ2E026Z	JACK , HEADPHONE(SILVER PLATE)	JACK	1	EA
JK85	CJJ9M003Z	JACK , S-VIDEO	JACK	1	EA
JK86	CJJ4S023Y	JACK , BOARD	JACK	1	EA
JW82	CWE8202300RV	WIRE ASS'Y	WIRE	1	EA
JW83	CWE8202150RV	WIRE ASS'Y	WIRE	1	EA
JW84	CWE8202110RV	WIRE ASS'Y	WIRE	1	EA
JW88	CWE8202150RV	WIRE ASS'Y	WIRE	1	EA
SW1	CSH1A008ZV	SW , PUSH (MOMS)	SWITCH	1	EA
	CMC3A111	PLATE , EARTH	Plate, earth	1	EA
	CHG1A306	CUSHION	CUSHION	1	EA
L702	HLQ02C100KT	COIL , AXAIL	10uH	1	EA
MAIN PCB/HEATSINK		(CUP12026)			
<i>Capacitors</i>					
C501	CCEA1HH100T	CAP , ELECT	10UF 50V	1	EA
C502	CCEA1HH100T	CAP , ELECT	10UF 50V	1	EA
C503	CCEA1HH100T	CAP , ELECT	10UF 50V	1	EA
C504	CCEA1HH100T	CAP , ELECT	10UF 50V	1	EA
C505	CCEA1HH100T	CAP , ELECT	10UF 50V	1	EA
C506	CCKT1H331KB	CAP , CERAMIC	330PF 50V	1	EA
C507	CCBS1H331KBT	CAP , CERAMIC	330PF 50V	1	EA
C508	CCBS1H331KBT	CAP , CERAMIC	330PF 50V	1	EA
C509	CCKT1H331KB	CAP , CERAMIC	330PF 50V	1	EA
C510	CCBS1H331KBT	CAP , CERAMIC	330PF 50V	1	EA
C561	CCEA1CH101T	CAP , ELECT	100UF 16V	1	EA
C562	CCEA1CH101T	CAP , ELECT	100UF 16V	1	EA
C564	CCEA1CH101T	CAP , ELECT	100UF 16V	1	EA
C565	CCEA1CH101T	CAP , ELECT	100UF 16V	1	EA
C566	CCEA1CH101T	CAP , ELECT	100UF 16V	1	EA
C567	CCEA1CH101T	CAP , ELECT	100UF 16V	1	EA
C568	CCEA1CH101T	CAP , ELECT	100UF 16V	1	EA
C569	CCEA1CH101T	CAP , ELECT	100UF 16V	1	EA
C570	CCEA1CH101T	CAP , ELECT	100UF 16V	1	EA

Ref. Designator	Part Number	Description		Qty	
MAIN PCB/HEATSINK		(CUP12026)			
C571	CCBS1H681KBT	CAP , CERAMIC	680PF 50V	1	EA
C572	CCBS1H681KBT	CAP , CERAMIC	680PF 50V	1	EA
C573	CCBS1H681KBT	CAP , CERAMIC	680PF 50V	1	EA
C574	CCBS1H681KBT	CAP , CERAMIC	680PF 50V	1	EA
C575	CCBS1H681KBT	CAP , CERAMIC	680PF 50V	1	EA
C601	CCCT1H120JC	CAP , CERAMIC	12PF 50V J	1	EA
C602	CCCT1H120JC	CAP , CERAMIC	12PF 50V J	1	EA
C603	CCCT1H120JC	CAP , CERAMIC	12PF 50V J	1	EA
C604	CCCT1H120JC	CAP , CERAMIC	12PF 50V J	1	EA
C605	CCCT1H120JC	CAP , CERAMIC	12PF 50V J	1	EA
C606	CCCT1H330JC	CAP , CERAMIC	33PF 50V J	1	EA
C607	CCCT1H330JC	CAP , CERAMIC	33PF 50V J	1	EA
C608	CCCT1H330JC	CAP , CERAMIC	33PF 50V J	1	EA
C609	CCCT1H330JC	CAP , CERAMIC	33PF 50V J	1	EA
C610	CCCT1H330JC	CAP , CERAMIC	33PF 50V J	1	EA
C681	CCEA1HH100T	CAP , ELECT	10UF 50V	1	EA
C682	CCEA1HH100T	CAP , ELECT	10UF 50V	1	EA
C683	CCEA1HH100T	CAP , ELECT	10UF 50V	1	EA
C684	CCEA1HH100T	CAP , ELECT	10UF 50V	1	EA
C685	CCEA1HH100T	CAP , ELECT	10UF 50V	1	EA
C726	CCKT1H221KB	CAP , CERAMIC	220PF 50V K	1	EA
C900	HCQ11H473JZT	CAP , MYLAR	0.047UF 50V J	1	EA
C901	HCQ11H473JZT	CAP , MYLAR	0.047UF 50V J	1	EA
C905	CCFT1H223ZF	CAP , CERAMIC	0.022UF 50V Z	1	EA
C907	CCEA1CH101T	CAP , ELECT	100UF 16V	1	EA
C908	CCFT1H223ZF	CAP , CERAMIC	0.022UF 50V Z	1	EA
C910	HCQ11H473JZT	CAP , MYLAR	0.047UF 50V J	1	EA
C911	CCEA1CH471T	CAP , ELECT	470UF 16V	1	EA
C912	CCEA1EH221T	CAP , ELECT	220UF 25V	1	EA
C913	CCFT1H104ZF	CAP , SEMICONDUCTOR	0.1UF 50V Z	1	EA
C914	HCQ11H473JZT	CAP , MYLAR	0.047UF 50V J	1	EA
C917	HCQ11H473JZT	CAP , MYLAR	0.047UF 50V J	1	EA
C924	CCFT1H104ZF	CAP , SEMICONDUCTOR	0.1UF 50V Z	1	EA
C939	CCEA1HH4R7T	CAP , ELECT	4.7UF 50V	1	EA
C940	CCEA1AH471T	CAP , ELECT	470UF 10V	1	EA
C948	CCFT1H104ZF	CAP , SEMICONDUCTOR	0.1UF 50V Z	1	EA
C971	HCQ11H562JZT	CAP , MYLAR	5600PF 50V J	1	EA
C972	HCQ11H562JZT	CAP , MYLAR	5600PF 50V J	1	EA
C973	HCQ11H562JZT	CAP , MYLAR	5600PF 50V J	1	EA
C977	CCEA1HH3R3T	CAP , ELECT	3.3UF 50V	1	EA
C980	HCQ11H562JZT	CAP , MYLAR	5600PF 50V J	1	EA
C981	HCQ11H562JZT	CAP , MYLAR	5600PF 50V J	1	EA
C990	HCQ11H473JZT	CAP , MYLAR	0.047UF 50V J	1	EA
C991	CCEA1HH1R0T	CAP , ELECT	1UF 50V	1	EA
C992	HCQ11H473JZT	CAP , MYLAR	0.047UF 50V J	1	EA
C993	HCQ11H473JZT	CAP , MYLAR	0.047UF 50V J	1	EA
C995	HCQ11H473JZT	CAP , MYLAR	0.047UF 50V J	1	EA
C997	HCQ11H473JZT	CAP , MYLAR	0.047UF 50V J	1	EA
C999	CCFT1H223ZF	CAP , CERAMIC	0.022UF 50V Z	1	EA
C563	CCEA1CH101T	CAP , ELECT	100UF 16V	1	EA
C631	CCEA1JH101E	CAP , ELECT	100UF 63V	1	EA
C632	CCEA1JH101E	CAP , ELECT	100UF 63V	1	EA
C633	CCEA1JH101E	CAP , ELECT	100UF 63V	1	EA
C634	CCEA1JH101E	CAP , ELECT	100UF 63V	1	EA
C635	CCEA1JH101E	CAP , ELECT	100UF 63V	1	EA
C636	CCEA1JH101E	CAP , ELECT	100UF 63V	1	EA
C637	CCEA1JH101E	CAP , ELECT	100UF 63V	1	EA
C638	CCEA1JH101E	CAP , ELECT	100UF 63V	1	EA
C639	CCEA1JH101E	CAP , ELECT	100UF 63V	1	EA
C640	CCEA1JH101E	CAP , ELECT	100UF 63V	1	EA
C902	CCET50VKL4682NK	CAP , ELECT	6800UF/50V	1	EA

Ref. Designator	Part Number	Description		Qty	
MAIN PCB/HEATSINK		(CUP12026)			
C904	KCKDKS472ME	CAP , CERAMIC(X1/Y2/SC)	0.0047UF/2.5KV	1	EA
C906	CCEA1EH102E	CAP , ELECT	1000UF 25V	1	EA
C909	CCET50VKL4682NK	CAP , ELECT	6800UF/50V	1	EA
C915	CCET50VKL4682NK	CAP , ELECT	6800UF/50V	1	EA
C916	CCET50VKL4682NK	CAP , ELECT	6800UF/50V	1	EA
<i>Semiconductors</i>					
D501	CVD1SS133MT	DIODE	1SS133	1	EA
D502	CVD1SS133MT	DIODE	1SS133	1	EA
D503	CVD1SS133MT	DIODE	1SS133	1	EA
D504	CVD1SS133MT	DIODE	1SS133	1	EA
D505	CVD1SS133MT	DIODE	1SS133	1	EA
D581	CVD1SS133MT	DIODE	1SS133	1	EA
D582	CVD1SS133MT	DIODE	1SS133	1	EA
D583	CVD1SS133MT	DIODE	1SS133	1	EA
D584	CVD1SS133MT	DIODE	1SS133	1	EA
D585	CVD1SS133MT	DIODE	1SS133	1	EA
D901	CVD1N4003SRT	DIODE , RECT	1N4003	1	EA
D902	CVD1SS133MT	DIODE	1SS133	1	EA
D911	CVD1SS133MT	DIODE	1SS133	1	EA
D912	CVD1SS133MT	DIODE	1SS133	1	EA
D914	CVD1SS133MT	DIODE	1SS133	1	EA
D917	CVD1SS133MT	DIODE	1SS133	1	EA
D953	CVD1SS133MT	DIODE	1SS133	1	EA
D954	CVD1N4003SRT	DIODE , RECT	1N4003	1	EA
D955	CVD1N4003SRT	DIODE , RECT	1N4003	1	EA
D956	CVD1N4003SRT	DIODE , RECT	1N4003	1	EA
D957	CVD1N4003SRT	DIODE , RECT	1N4003	1	EA
D961	CVD1N4003ST	DIODE , RECT	1N4003	1	EA
D962	CVD1N4003SRT	DIODE , RECT	1N4003	1	EA
D963	CVD1N4003SRT	DIODE , RECT	1N4003	1	EA
D973	CVD1SS133MT	DIODE	1SS133	1	EA
D974	CVD1SS133MT	DIODE	1SS133	1	EA
D979	CVDZJ5.1BT	DIODE , ZENER	ZJ5.1B 1/2W	1	EA
IC97	HVIRE5VT28CATZ	I.C , RESET	RESET	1	EA
Q501	HVTKTA1268GRT	TRANSISTOR PNP	KTA1268GR	1	EA
Q502	HVTKTA1268GRT	TRANSISTOR PNP	KTA1268GR	1	EA
Q503	HVTKTA1268GRT	TRANSISTOR PNP	KTA1268GR	1	EA
Q504	HVTKTA1268GRT	TRANSISTOR PNP	KTA1268GR	1	EA
Q505	HVTKTA1268GRT	TRANSISTOR PNP	KTA1268GR	1	EA
Q511	HVTKTC3200GRT	TRANSISTOR NPN	KTC3200GR	1	EA
Q512	HVTKTC3200GRT	TRANSISTOR NPN	KTC3200GR	1	EA
Q513	HVTKTC3200GRT	TRANSISTOR NPN	KTC3200GR	1	EA
Q514	HVTKTC3200GRT	TRANSISTOR NPN	KTC3200GR	1	EA
Q515	HVTKTC3200GRT	TRANSISTOR NPN	KTC3200GR	1	EA
Q516	HVTKTC3200GRT	TRANSISTOR NPN	KTC3200GR	1	EA
Q517	HVTKTC3200GRT	TRANSISTOR NPN	KTC3200GR	1	EA
Q518	HVTKTC3200GRT	TRANSISTOR NPN	KTC3200GR	1	EA
Q519	HVTKTC3200GRT	TRANSISTOR NPN	KTC3200GR	1	EA
Q520	HVTKTC3200GRT	TRANSISTOR NPN	KTC3200GR	1	EA
Q541	HVTKTC3198YT	TRANSISTOR NPN	KTC3198Y	1	EA
Q542	HVTKTC3198YT	TRANSISTOR NPN	KTC3198Y	1	EA
Q543	HVTKTC3198YT	TRANSISTOR NPN	KTC3198Y	1	EA
Q544	HVTKTC3198YT	TRANSISTOR NPN	KTC3198Y	1	EA
Q545	HVTKTC3198YT	TRANSISTOR NPN	KTC3198Y	1	EA
Q556	HVTKTC3200GRT	TRANSISTOR NPN	KTC3200GR	1	EA
Q557	HVTKTC3200GRT	TRANSISTOR NPN	KTC3200GR	1	EA

Ref. Designator	Part Number	Description		Qty	
MAIN PCB/HEATSINK		(CUP12026)			
Q558	HVTKTC3200GRT	TRANSISTOR NPN	KTC3200GR	1	EA
Q559	HVTKTC3200GRT	TRANSISTOR NPN	KTC3200GR	1	EA
Q560	HVTKTC3200GRT	TRANSISTOR NPN	KTC3200GR	1	EA
Q561	HVTKTC3200GRT	TRANSISTOR NPN	KTC3200GR	1	EA
Q562	HVTKTC3200GRT	TRANSISTOR NPN	KTC3200GR	1	EA
Q563	HVTKTC3200GRT	TRANSISTOR NPN	KTC3200GR	1	EA
Q564	HVTKTC3200GRT	TRANSISTOR NPN	KTC3200GR	1	EA
Q565	HVTKTC3200GRT	TRANSISTOR NPN	KTC3200GR	1	EA
Q601	HVTKTA1268GRT	TRANSISTOR PNP	KTA1268GR	1	EA
Q602	HVTKTA1268GRT	TRANSISTOR PNP	KTA1268GR	1	EA
Q603	HVTKTA1268GRT	TRANSISTOR PNP	KTA1268GR	1	EA
Q604	HVTKTA1268GRT	TRANSISTOR PNP	KTA1268GR	1	EA
Q605	HVTKTA1268GRT	TRANSISTOR PNP	KTA1268GR	1	EA
Q681	HVTKSC2785YT	TRANSISTOR NPN	KSC2785Y	1	EA
Q682	HVTKSC2785YT	TRANSISTOR NPN	KSC2785Y	1	EA
Q683	HVTKSC2785YT	TRANSISTOR NPN	KSC2785Y	1	EA
Q684	HVTKSC2785YT	TRANSISTOR NPN	KSC2785Y	1	EA
Q685	HVTKSC2785YT	TRANSISTOR NPN	KSC2785Y	1	EA
Q901	HVTKSC2785YT	TRANSISTOR NPN	KSC2785Y	1	EA
Q938	HVTKRA107MT	TRANSISTOR PNP	KRA107M	1	EA
Q939	HVTKRA107MT	TRANSISTOR PNP	KRA107M	1	EA
Q941	HVTKSC2785YT	TRANSISTOR NPN	KSC2785Y	1	EA
Q942	HVTKSC2785YT	TRANSISTOR NPN	KSC2785Y	1	EA
Q943	HVTKSC2785YT	TRANSISTOR NPN	KSC2785Y	1	EA
Q951	HVTKRC107MT	TRANSISTOR NPN	KRC107M	1	EA
Q952	HVTKRA107MT	TRANSISTOR PNP	KRA107M	1	EA
Q960	HVTKRC107MT	TRANSISTOR NPN	KRC107M	1	EA
Q961	HVTKTA1024YT	TRANSISTOR PNP	KTA1024Y	1	EA
Q991	HVTKRC107MT	TRANSISTOR NPN	KRC107M	1	EA
Q992	HVTKRA107MT	TRANSISTOR PNP	KRA107M	1	EA
Q652	HVT2SB1559P-OKM	TR , POWER (DARLINGTON TYPE)	2SB1559	1	EA
Q653	HVT2SB1559P-OKM	TR , POWER (DARLINGTON TYPE)	2SB1559	1	EA
Q654	HVT2SB1559P-OKM	TR , POWER (DARLINGTON TYPE)	2SB1559	1	EA
Q655	HVT2SB1559P-OKM	TR , POWER (DARLINGTON TYPE)	2SB1559	1	EA
Q657	HVT2SD2389P-OKM	TR , POWER (DARLINGTON TYPE)	2SB1559	1	EA
Q658	HVT2SD2389P-OKM	TR , POWER (DARLINGTON TYPE)	2SB1559	1	EA
Q659	HVT2SD2389P-OKM	TR , POWER (DARLINGTON TYPE)	2SB1559	1	EA
Q660	HVT2SD2389P-OKM	TR , POWER (DARLINGTON TYPE)	2SB1559	1	EA
Q661	HVT2SB1559P-OKM	TR , POWER (DARLINGTON TYPE)	2SB1559	1	EA
Q670	HVT2SD2389P-OKM	TR , POWER (DARLINGTON TYPE)	2SB1559	1	EA
Q858	HVT2SA1360O	TRANSISTOR , POWER, PNP	2SA1360O	1	EA
Q871	HVT2SA1360O	TRANSISTOR , POWER, PNP	2SA1360O	1	EA
Q872	HVT2SA1360O	TRANSISTOR , POWER, PNP	2SA1360O	1	EA
Q874	HVT2SA1360O	TRANSISTOR , POWER, PNP	2SA1360O	1	EA
Q875	HVT2SA1360O	TRANSISTOR , POWER, PNP	2SA1360O	1	EA
Q881	HVT2SC3423O	TRANSISTOR , POWER, NPN	2SC3423O	1	EA
Q882	HVT2SC3423O	TRANSISTOR , POWER, NPN	2SC3423O	1	EA
Q883	HVT2SC3423O	TRANSISTOR , POWER, NPN	2SC3423O	1	EA
Q884	HVT2SC3423O	TRANSISTOR , POWER, NPN	2SC3423O	1	EA
Q885	HVT2SC3423O	TRANSISTOR , POWER, NPN	2SC3423O	1	EA
<i>Resistors</i>					
R501	CRD20TJ433T	RES , CARBON	43K OHM 1/5W J	1	EA
R502	CRD20TJ433T	RES , CARBON	43K OHM 1/5W J	1	EA
R503	CRD20TJ433T	RES , CARBON	43K OHM 1/5W J	1	EA
R504	CRD20TJ433T	RES , CARBON	43K OHM 1/5W J	1	EA
R505	CRD20TJ433T	RES , CARBON	43K OHM 1/5W J	1	EA
R506	CRD20TJ333T	RES , CARBON	33K OHM 1/5W J	1	EA
R507	CRD20TJ333T	RES , CARBON	33K OHM 1/5W J	1	EA
R508	CRD20TJ333T	RES , CARBON	33K OHM 1/5W J	1	EA

Ref. Designator	Part Number	Description		Qty	
MAIN PCB/HEATSINK		(CUP12026)			
R509	CRD20TJ333T	RES , CARBON	33K OHM 1/5W J	1	EA
R510	CRD20TJ333T	RES , CARBON	33K OHM 1/5W J	1	EA
R511	CRD20TJ152T	RES , CARBON	1.5K OHM 1/5W J	1	EA
R512	CRD20TJ152T	RES , CARBON	1.5K OHM 1/5W J	1	EA
R513	CRD20TJ152T	RES , CARBON	1.5K OHM 1/5W J	1	EA
R514	CRD20TJ152T	RES , CARBON	1.5K OHM 1/5W J	1	EA
R515	CRD20TJ152T	RES , CARBON	1.5K OHM 1/5W J	1	EA
R516	CRD20TJ152T	RES , CARBON	1.5K OHM 1/5W J	1	EA
R517	CRD20TJ152T	RES , CARBON	1.5K OHM 1/5W J	1	EA
R518	CRD20TJ152T	RES , CARBON	1.5K OHM 1/5W J	1	EA
R519	CRD20TJ152T	RES , CARBON	1.5K OHM 1/5W J	1	EA
R520	CRD20TJ152T	RES , CARBON	1.5K OHM 1/5W J	1	EA
R521	CRD20TJ471T	RES , CARBON	470 OHM 1/5W J	1	EA
R522	CRD20TJ471T	RES , CARBON	470 OHM 1/5W J	1	EA
R523	CRD20TJ471T	RES , CARBON	470 OHM 1/5W J	1	EA
R524	CRD20TJ471T	RES , CARBON	470 OHM 1/5W J	1	EA
R525	CRD20TJ471T	RES , CARBON	470 OHM 1/5W J	1	EA
R531	CRD20TJ221T	RES , CARBON	220 OHM 1/5W J	1	EA
R532	CRD20TJ221T	RES , CARBON	220 OHM 1/5W J	1	EA
R533	CRD20TJ221T	RES , CARBON	220 OHM 1/5W J	1	EA
R534	CRD20TJ221T	RES , CARBON	220 OHM 1/5W J	1	EA
R535	CRD20TJ221T	RES , CARBON	220 OHM 1/5W J	1	EA
R536	CRD20TJ221T	RES , CARBON	220 OHM 1/5W J	1	EA
R537	CRD20TJ221T	RES , CARBON	220 OHM 1/5W J	1	EA
R538	CRD20TJ221T	RES , CARBON	220 OHM 1/5W J	1	EA
R539	CRD20TJ221T	RES , CARBON	220 OHM 1/5W J	1	EA
R540	CRD20TJ221T	RES , CARBON	220 OHM 1/5W J	1	EA
R541	CRD20TJ271T	RES , CARBON	270 OHM 1/5W J	1	EA
R542	CRD20TJ271T	RES , CARBON	270 OHM 1/5W J	1	EA
R543	CRD20TJ271T	RES , CARBON	270 OHM 1/5W J	1	EA
R544	CRD20TJ271T	RES , CARBON	270 OHM 1/5W J	1	EA
R545	CRD20TJ271T	RES , CARBON	270 OHM 1/5W J	1	EA
R556	CRD20TJ273T	RES , CARBON	27K OHM 1/5W J	1	EA
R557	CRD20TJ273T	RES , CARBON	27K OHM 1/5W J	1	EA
R558	CRD20TJ273T	RES , CARBON	27K OHM 1/5W J	1	EA
R559	CRD20TJ273T	RES , CARBON	27K OHM 1/5W J	1	EA
R560	CRD20TJ273T	RES , CARBON	27K OHM 1/5W J	1	EA
R561	CRD20TJ182T	RES , CARBON	1.8K OHM 1/5W J	1	EA
R562	CRD20TJ182T	RES , CARBON	1.8K OHM 1/5W J	1	EA
R563	CRD20TJ182T	RES , CARBON	1.8K OHM 1/5W J	1	EA
R564	CRD20TJ182T	RES , CARBON	1.8K OHM 1/5W J	1	EA
R565	CRD20TJ182T	RES , CARBON	1.8K OHM 1/5W J	1	EA
R566	CRD20TJ561T	RES , CARBON	560 OHM 1/5W J	1	EA
R567	CRD20TJ561T	RES , CARBON	560 OHM 1/5W J	1	EA
R568	CRD20TJ561T	RES , CARBON	560 OHM 1/5W J	1	EA
R569	CRD20TJ561T	RES , CARBON	560 OHM 1/5W J	1	EA
R570	CRD20TJ561T	RES , CARBON	560 OHM 1/5W J	1	EA
R571	CRD20TJ561T	RES , CARBON	560 OHM 1/5W J	1	EA
R572	CRD20TJ561T	RES , CARBON	560 OHM 1/5W J	1	EA
R573	CRD20TJ561T	RES , CARBON	560 OHM 1/5W J	1	EA
R574	CRD20TJ561T	RES , CARBON	560 OHM 1/5W J	1	EA
R575	CRD20TJ561T	RES , CARBON	560 OHM 1/5W J	1	EA
R576	CRD20TJ100T	RES , CARBON	10 OHM 1/5W J	1	EA
R577	CRD20TJ100T	RES , CARBON	10 OHM 1/5W J	1	EA
R578	CRD20TJ100T	RES , CARBON	10 OHM 1/5W J	1	EA
R579	CRD20TJ100T	RES , CARBON	10 OHM 1/5W J	1	EA
R580	CRD20TJ100T	RES , CARBON	10 OHM 1/5W J	1	EA
R581	CRD20TJ561T	RES , CARBON	560 OHM 1/5W J	1	EA
R582	CRD20TJ561T	RES , CARBON	560 OHM 1/5W J	1	EA
R583	CRD20TJ561T	RES , CARBON	560 OHM 1/5W J	1	EA
R584	CRD20TJ561T	RES , CARBON	560 OHM 1/5W J	1	EA

Ref. Designator	Part Number	Description		Qty	
MAIN PCB/HEATSINK		(CUP12026)			
R585	CRD20TJ561T	RES , CARBON	560 OHM 1/5W J	1	EA
R586	CRD20TJ561T	RES , CARBON	560 OHM 1/5W J	1	EA
R587	CRD20TJ561T	RES , CARBON	560 OHM 1/5W J	1	EA
R588	CRD20TJ561T	RES , CARBON	560 OHM 1/5W J	1	EA
R589	CRD20TJ561T	RES , CARBON	560 OHM 1/5W J	1	EA
R590	CRD20TJ561T	RES , CARBON	560 OHM 1/5W J	1	EA
R591	CRD20TJ561T	RES , CARBON	560 OHM 1/5W J	1	EA
R592	CRD20TJ561T	RES , CARBON	560 OHM 1/5W J	1	EA
R593	CRD20TJ561T	RES , CARBON	560 OHM 1/5W J	1	EA
R594	CRD20TJ561T	RES , CARBON	560 OHM 1/5W J	1	EA
R595	CRD20TJ561T	RES , CARBON	560 OHM 1/5W J	1	EA
R596	CRD20TJ561T	RES , CARBON	560 OHM 1/5W J	1	EA
R597	CRD20TJ561T	RES , CARBON	560 OHM 1/5W J	1	EA
R598	CRD20TJ561T	RES , CARBON	560 OHM 1/5W J	1	EA
R599	CRD20TJ561T	RES , CARBON	560 OHM 1/5W J	1	EA
R600	CRD20TJ561T	RES , CARBON	560 OHM 1/5W J	1	EA
R601	CRD20TJ223T	RES , CARBON	22K OHM 1/5W J	1	EA
R602	CRD20TJ223T	RES , CARBON	22K OHM 1/5W J	1	EA
R603	CRD20TJ223T	RES , CARBON	22K OHM 1/5W J	1	EA
R604	CRD20TJ223T	RES , CARBON	22K OHM 1/5W J	1	EA
R605	CRD20TJ223T	RES , CARBON	22K OHM 1/5W J	1	EA
R606	CRD20TJ223T	RES , CARBON	22K OHM 1/5W J	1	EA
R607	CRD20TJ223T	RES , CARBON	22K OHM 1/5W J	1	EA
R608	CRD20TJ223T	RES , CARBON	22K OHM 1/5W J	1	EA
R609	CRD20TJ223T	RES , CARBON	22K OHM 1/5W J	1	EA
R610	CRD20TJ223T	RES , CARBON	22K OHM 1/5W J	1	EA
R631	CRD25FJ180T	RES , CARBON	18 OHM 1/5W J	1	EA
R632	CRD25FJ180T	RES , CARBON	18 OHM 1/5W J	1	EA
R633	CRD25FJ180T	RES , CARBON	18 OHM 1/5W J	1	EA
R634	CRD25FJ180T	RES , CARBON	18 OHM 1/5W J	1	EA
R635	CRD25FJ180T	RES , CARBON	18 OHM 1/5W J	1	EA
R636	CRD25FJ180T	RES , CARBON	18 OHM 1/5W J	1	EA
R637	CRD25FJ180T	RES , CARBON	18 OHM 1/5W J	1	EA
R638	CRD25FJ180T	RES , CARBON	18 OHM 1/5W J	1	EA
R639	CRD25FJ180T	RES , CARBON	18 OHM 1/5W J	1	EA
R640	CRD25FJ180T	RES , CARBON	18 OHM 1/5W J	1	EA
R646	CRD25FJ3R3T	RES , CARBON	3.3 OHM 1/4W J	1	EA
R647	CRD25FJ3R3T	RES , CARBON	3.3 OHM 1/4W J	1	EA
R648	CRD25FJ3R3T	RES , CARBON	3.3 OHM 1/4W J	1	EA
R649	CRD25FJ3R3T	RES , CARBON	3.3 OHM 1/4W J	1	EA
R650	CRD25FJ3R3T	RES , CARBON	3.3 OHM 1/4W J	1	EA
R651	CRD25FJ3R3T	RES , CARBON	3.3 OHM 1/4W J	1	EA
R652	CRD25FJ3R3T	RES , CARBON	3.3 OHM 1/4W J	1	EA
R653	CRD25FJ3R3T	RES , CARBON	3.3 OHM 1/4W J	1	EA
R654	CRD25FJ3R3T	RES , CARBON	3.3 OHM 1/4W J	1	EA
R655	CRD25FJ3R3T	RES , CARBON	3.3 OHM 1/4W J	1	EA
R666	CRD25TJ470T	RES , CARBON	47 OHM 1/5W J	1	EA
R667	CRD25TJ470T	RES , CARBON	47 OHM 1/5W J	1	EA
R668	CRD25TJ470T	RES , CARBON	47 OHM 1/5W J	1	EA
R669	CRD25TJ470T	RES , CARBON	47 OHM 1/5W J	1	EA
R670	CRD25TJ470T	RES , CARBON	47 OHM 1/5W J	1	EA
R671	CRD20TJ472T	RES , CARBON	4.7K OHM 1/5W J	1	EA
R672	CRD20TJ472T	RES , CARBON	4.7K OHM 1/5W J	1	EA
R673	CRD20TJ472T	RES , CARBON	4.7K OHM 1/5W J	1	EA
R674	CRD20TJ472T	RES , CARBON	4.7K OHM 1/5W J	1	EA
R675	CRD20TJ472T	RES , CARBON	4.7K OHM 1/5W J	1	EA
R676	CRD25TJ182T	RES , CARBON	1.8K OHM 1/5W J	1	EA
R677	CRD25TJ182T	RES , CARBON	1.8K OHM 1/5W J	1	EA
R678	CRD25TJ182T	RES , CARBON	1.8K OHM 1/5W J	1	EA
R679	CRD25TJ182T	RES , CARBON	1.8K OHM 1/5W J	1	EA
R680	CRD25TJ182T	RES , CARBON	1.8K OHM 1/5W J	1	EA

Ref. Designator	Part Number	Description		Qty	
MAIN PCB/HEATSINK		(CUP12026)			
R681	CRD20TJ562T	RES , CARBON	5.6K OHM 1/5W J	1	EA
R682	CRD20TJ562T	RES , CARBON	5.6K OHM 1/5W J	1	EA
R683	CRD20TJ562T	RES , CARBON	5.6K OHM 1/5W J	1	EA
R684	CRD20TJ562T	RES , CARBON	5.6K OHM 1/5W J	1	EA
R685	CRD20TJ562T	RES , CARBON	5.6K OHM 1/5W J	1	EA
R686	CRD20TJ103T	RES , CARBON	10K OHM 1/5W J	1	EA
R687	CRD20TJ103T	RES , CARBON	10K OHM 1/5W J	1	EA
R688	CRD20TJ103T	RES , CARBON	10K OHM 1/5W J	1	EA
R689	CRD20TJ103T	RES , CARBON	10K OHM 1/5W J	1	EA
R690	CRD20TJ103T	RES , CARBON	10K OHM 1/5W J	1	EA
R696	CRD25TJ470T	RES , CARBON	47 OHM 1/4W J	1	EA
R697	CRD25TJ470T	RES , CARBON	47 OHM 1/4W J	1	EA
R698	CRD25TJ470T	RES , CARBON	47 OHM 1/4W J	1	EA
R699	CRD25TJ470T	RES , CARBON	47 OHM 1/4W J	1	EA
R700	CRD25TJ470T	RES , CARBON	47 OHM 1/4W J	1	EA
R706	USE BUSS WIRE	WIRE , COPPER		1	EA
R771	CRD20TJ750T	RES , CARBON	75 OHM 1/5W J	1	EA
R772	CRD20TJ750T	RES , CARBON	75 OHM 1/5W J	1	EA
R773	CRD20TJ750T	RES , CARBON	75 OHM 1/5W J	1	EA
R774	CRD20TJ750T	RES , CARBON	75 OHM 1/5W J	1	EA
R775	CRD20TJ750T	RES , CARBON	75 OHM 1/5W J	1	EA
R781	CRD20TJ750T	RES , CARBON	75 OHM 1/5W J	1	EA
R782	CRD20TJ750T	RES , CARBON	75 OHM 1/5W J	1	EA
R783	CRD20TJ750T	RES , CARBON	75 OHM 1/5W J	1	EA
R784	CRD20TJ750T	RES , CARBON	75 OHM 1/5W J	1	EA
R785	CRD20TJ750T	RES , CARBON	75 OHM 1/5W J	1	EA
R900	CRD20TJ103T	RES , CARBON	10K OHM 1/5W J	1	EA
R901	CRD25TJ393T	RES , CARBON	39K OHM 1/4W J	1	EA
R902	CRD25TJ393T	RES , CARBON	39K OHM 1/4W J	1	EA
R903	CRD25TJ393T	RES , CARBON	39K OHM 1/4W J	1	EA
R906	CRD25TJ393T	RES , CARBON	39K OHM 1/4W J	1	EA
R907	CRD20TJ103T	RES , CARBON	10K OHM 1/5W J	1	EA
R910	CRD20TJ105T	RES , CARBON	1M OHM 1/5W J	1	EA
R912	CRD20TJ332T	RES , CARBON	3.3K OHM 1/5W J	1	EA
R913	USE BUSS WIRE	WIRE , COPPER		1	EA
R917	CRD25TJ393T	RES , CARBON	39K OHM 1/4W J	1	EA
R918	CRD25TJ393T	RES , CARBON	39K OHM 1/4W J	1	EA
R919	CRD25TJ393T	RES , CARBON	39K OHM 1/4W J	1	EA
R920	CRD25TJ393T	RES , CARBON	39K OHM 1/4W J	1	EA
R932	CRD20TJ103T	RES , CARBON	10K OHM 1/5W J	1	EA
R939	CRD20TJ472T	RES , CARBON	4.7K OHM 1/5W J	1	EA
R940	CRD20TJ152T	RES , CARBON	1.5K OHM 1/5W J	1	EA
R941	CRD20TJ223T	RES , CARBON	22K OHM 1/5W J	1	EA
R942	CRD20TJ223T	RES , CARBON	22K OHM 1/5W J	1	EA
R944	CRD25TJ223T	RES , CARBON	22K OHM 1/4W J	1	EA
R946	CRD25TJ223T	RES , CARBON	22K OHM 1/4W J	1	EA
R947	CRD20TJ223T	RES , CARBON	22K OHM 1/5W J	1	EA
R948	CRD25TJ153T	RES , CARBON	15K OHM 1/4W J	1	EA
R955	CRD20TJ203T	RES , CARBON	20K OHM 1/5W J	1	EA
R956	CRD20TJ394T	RES , CARBON	390K OHM 1/5W J	1	EA
R957	CRD20TJ153T	RES , CARBON	15K OHM 1/5W J	1	EA
R960	CRD20TJ332T	RES , CARBON	3.3K OHM 1/5W J	1	EA
R961	CRD20TJ331T	RES , CARBON	330 OHM 1/5W J	1	EA
R962	CRD20TJ273T	RES , CARBON	27K OHM 1/5W J	1	EA
R963	CRD20TJ105T	RES , CARBON	1M OHM 1/5W J	1	EA
R966	CRD20TJ472T	RES , CARBON	4.7K OHM 1/5W J	1	EA
R986	CRD20TJ102T	RES , CARBON	1K OHM 1/5W J	1	EA
R987	CRD20TJ561T	RES , CARBON	560 OHM 1/5W J	1	EA
R988	CRD20TJ562T	RES , CARBON	5.6K OHM 1/5W J	1	EA
R989	CRD20TJ302T	RES , CARBON	3K OHM 1/5W J	1	EA
R991	CRD20TJ822T	RES , CARBON	8.2K OHM 1/5W J	1	EA

Ref. Designator	Part Number	Description		Qty	
MAIN PCB/HEATSINK		(CUP12026)			
R992	CRD20TJ562T	RES , CARBON	5.6K OHM 1/5W J	1	EA
R998	CRD20TJ103T	RES , CARBON	10K OHM 1/5W J	1	EA
R656	CRF5EKR27HX2K	RES , CEMENT	0.27ohm X 2	1	EA
R657	CRF5EKR27HX2K	RES , CEMENT	0.27ohm X 2	1	EA
R658	CRF5EKR27HX2K	RES , CEMENT	0.27ohm X 2	1	EA
R659	CRF5EKR27HX2K	RES , CEMENT	0.27ohm X 2	1	EA
R660	CRF5EKR27HX2K	RES , CEMENT	0.27ohm X 2	1	EA
R905	CRG1ANJ1R0H	RES , METAL OXIDE FILM	1 OHM 1W J	1	EA
R911	CRG1ANJ271H	RES , METAL OXIDE(270/1W)	270 OHM 1W J	1	EA
R990	CRG1ANJ100H	RES , METAL OXIDE FILM	10 OHM 1W J	1	EA
R993	CRG1ANJ100H	RES , METAL OXIDE FILM	10 OHM 1W J	1	EA
R995	CRG1ANJ100H	RES , METAL OXIDE FILM	10 OHM 1W J	1	EA
R997	CRG1ANJ100H	RES , METAL OXIDE FILM	10 OHM 1W J	1	EA
R999	CRG1ANJ100H	RES , METAL OXIDE FILM	10 OHM 1W J	1	EA
<i>Miscellaneous</i>					
	CMYAVR154	HEAT SINK ASS'Y	ASS'Y	1	EA
	CHD1A012R	SCREW , SPECIAL	SCREW	15	EA
	CHD3A012R	SCREW , SPECIAL	SCREW	2	EA
	CMD1A398	BRACKET , PCB	BRACKET	2	EA
	CMD1A417	BRACKET , PCB	BRACKET	2	EA
	CMY1A273	HEAT SINK	HEAT SINK	1	EA
	CTB3+8JR	SCREW	SCREW	6	EA
ET90	HJT1A025	PLATE , EARTH	MET37-0002	1	EA
ET91	HJT1A025	PLATE , EARTH	MET37-0002	1	EA
F901	KJCF5S	HOLDER , FUSE	HOLDER	2	EA
	CTW3+8JR	SCREW	SCREW	2	EA
	CWE8202150AA	WIRE ASS'Y	WIRE	1	EA
BN19	CWB3FE03250UP	WIRE ASS'Y	WIRE	1	EA
BN20	CWB3FC04280UP	WIRE ASS'Y	WIRE	1	EA
BN82	CWB1C902050EN	WIRE ASS'Y	WIRE	1	EA
BN83	CWB1C902050EN	WIRE ASS'Y	WIRE	1	EA
BN84	CWB1C902050EN	WIRE ASS'Y	WIRE	1	EA
BN85	CWB1C902050EN	WIRE ASS'Y	WIRE	1	EA
BN86	CWB1C902050EN	WIRE ASS'Y	WIRE	1	EA
BN90	CWB4F232550PU	WIRE ASS'Y	WIRE	1	EA
BN98	HJP08GA130ZK	WAFER	WAFER	1	EA
BN99	CWB1C902250BM	WIRE ASS'Y	WIRE	1	EA
CN11	CJP13GA117ZY	WAFER , CARD CABLE	WAFER	1	EA
CN12	CJP21GA115ZY	WAFER , CARD CABLE	WAFER	1	EA
CN61	CJP02GA01ZY	WAFER , STRAIGHT, 2PIN	WAFER	1	EA
CN62	CJP02GA01ZY	WAFER , STRAIGHT, 2PIN	WAFER	1	EA
CN63	CJP02GA01ZY	WAFER , STRAIGHT, 2PIN	WAFER	1	EA
CN64	CJP02GA01ZY	WAFER , STRAIGHT, 2PIN	WAFER	1	EA
CN65	CJP02GA01ZY	WAFER , STRAIGHT, 2PIN	WAFER	1	EA
CN91	CJP02GA89ZY	WAFER	WAFER	1	EA
CN92	CJP02KA060ZY	WAFER	WAFER	1	EA
ET01	CMD1A387	BRACKET , PCB	BRACKET	1	EA
JK90	CJJ4M040Z	JACK , BOARD (SW)	JACK	1	EA
JK91	CJJ5R006Z	TERMINAL , SPEAKER	TERMINAL	1	EA
JK92	CJJ5P020Z	TERMINAL , SPEAKER	TERMINAL	1	EA
JW90	CWE8212120VV	WIRE , RED	WIRE	1	EA
JW91	CWE8212180VV	WIRE ASS'Y	WIRE	1	EA
JW92	CWEE212080VV	WIRE ASS'Y	WIRE	1	EA
L501	CLEY0R5KAK	COIL , SPEAKER	0.5UH K	1	EA
L502	CLEY0R5KAK	COIL , SPEAKER	0.5UH K	1	EA
L503	CLEY0R5KAK	COIL , SPEAKER	0.5UH K	1	EA
L504	CLEY0R5KAK	COIL , SPEAKER	0.5UH K	1	EA
L505	CLEY0R5KAK	COIL , SPEAKER	0.5UH K	1	EA
RY94	CSL1E002ZE	RELAY , POWER	G5PA-1 (DC 6V)	1	EA

Ref. Designator	Part Number	Description		Qty	
MAIN PCB/HEATSINK		(CUP12026)			
TH91	KRTP42T7D330B	THERMAL SENSOR , POSISTOR	P42T7D330BW20	1	EA
T902	CLT5I009ZU	TRANS , SUB C515	TRANS	1	EA
	CHD3A012R	SCREW , SPECIAL	SCREW	3	EA
PCB , POWER TRANS/DOWNLOAD/DIG IN/OUT		CUP12101			
<i>Capacitors</i>					
C104	CCBS1E103ZFT	CAP , CERAMIC	0.01UF 25V	1	EA
C105	CCBS1E103ZFT	CAP , CERAMIC	0.01UF 25V	1	EA
C106	CCFT1H104ZF	CAP , SEMICONDUCTOR	0.1UF 50V Z	1	EA
C107	CCBS1E103ZFT	CAP , CERAMIC	0.01UF 25V	1	EA
C108	CCBS1E103ZFT	CAP , CERAMIC	0.01UF 25V	1	EA
C109	CCFT1H104ZF	CAP , SEMICONDUCTOR	0.1UF 50V Z	1	EA
C117	CCEA1HH4R7T	CAP , ELECT	4.7UF 50V	1	EA
C118	CCBS1E103ZFT	CAP , CERAMIC	0.01UF 25V	1	EA
C119	CCEA1JH470TS	CAP , ELECT	63V/47UF/105°C	1	EA
C120	CCEA1JH470TS	CAP , ELECT	63V/47UF/105°C	1	EA
C121	CCBS1E103ZFT	CAP , CERAMIC	0.01UF 25V	1	EA
C131	CCEA1HH3R3T	CAP , ELECT	3.3UF 50V	1	EA
C750	CCEA1CH101T	CAP , ELECT	100UF 16V	1	EA
C751	CCEA1CH101T	CAP , ELECT	100UF 16V	1	EA
C852	CCEA1HH100T	CAP , ELECT	10UF 50V	1	EA
C853	CCEA1HH100T	CAP , ELECT	10UF 50V	1	EA
C854	CCEA1HH100T	CAP , ELECT	10UF 50V	1	EA
C855	CCEA1HH100T	CAP , ELECT	10UF 50V	1	EA
C856	CCEA1HH100T	CAP , ELECT	10UF 50V	1	EA
C902	CCBS1H223ZFT	CAP , CERAMIC	0.022UF 50V	1	EA
C903	CCBS1H223ZFT	CAP , CERAMIC	0.022UF 50V	1	EA
C906	CCEA1CKS220T	CAP , ELECT	22UF 16V SMALL SIZE	1	EA
C907	CCEA1CH101T	CAP , ELECT	100UF 16V	1	EA
C911	CCEA1HKS2R2T	CAP , ELECT	2.2UF 50V SMALL SIZE	1	EA
C912	CCEA0JH102T	CAP , ELECT	1000UF 6.3V	1	EA
C919	CCKT1H102KB	CAP , CERAMIC	1000PF 50V K	1	EA
C920	CCEA1HH470T	CAP , ELECT	47UF 50V	1	EA
C921	HCQI1H104JZT	CAP , MYLAR	0.1UF 50V J	1	EA
C922	HCQI1H104JZT	CAP , MYLAR	0.1UF 50V J	1	EA
C923	HCQI1H104JZT	CAP , MYLAR	0.1UF 50V J	1	EA
C924	HCQI1H104JZT	CAP , MYLAR	0.1UF 50V J	1	EA
C925	HCQI1H103JZT	CAP , MYLAR	0.01UF 50V J	1	EA
C926	HCQI1H103JZT	CAP , MYLAR	0.01UF 50V J	1	EA
C927	HCQI1H103JZT	CAP , MYLAR	0.01UF 50V J	1	EA
C928	HCQI1H103JZT	CAP , MYLAR	0.01UF 50V J	1	EA
C931	HCQI1H473JZT	CAP , MYLAR	0.047UF 50V J	1	EA
C932	HCQI1H473JZT	CAP , MYLAR	0.047UF 50V J	1	EA
C933	HCQI1H473JZT	CAP , MYLAR	0.047UF 50V J	1	EA
C934	HCQI1H473JZT	CAP , MYLAR	0.047UF 50V J	1	EA
C935	CCBS1H223ZFT	CAP , CERAMIC(22000PF/50V)	0.022UF 50V	1	EA
C936	CCBS1H223ZFT	CAP , CERAMIC(22000PF/50V)	0.022UF 50V	1	EA
C937	CCBS1H223ZFT	CAP , CERAMIC(22000PF/50V)	0.022UF 50V	1	EA
C938	CCEA1CH101T	CAP , ELECT	100UF 16V	1	EA
C939	CCEA1EH101T	CAP , ELECT	100UF 25V	1	EA
C940	CCEA1EH101T	CAP , ELECT	100UF 25V	1	EA
C122	CCEA1JH101E	CAP , ELECT	100UF 63V	1	EA
C929	CCEA1VH222EZ	CAP , ELECT (2200UF/35V, 12.5X31)	KR3-35V222MH1-L/C4.0	1	EA
C930	CCEA1VH222EZ	CAP , ELECT (2200UF/35V, 12.5X31)	KR3-35V222MH1-L/C4.0	1	EA
C941	CCEA1EH822E	CAP , ELECT(KR3, 8200UF/25V, 18X30)	KR3-25V822MU	1	EA
<i>Semiconductors</i>					
D101	CVDZJ15BT	DIODE , ZENER	ZJ15B 1/2W	1	EA

Ref. Designator	Part Number	Description		Qty	
PCB , POWER TRANS/DOWNLOAD/DIG IN/OUT CUP12101					
D102	HVDMTZJ27BT	DIODE , ZENER	MTZJ27B 1/2W	1	EA
D104	CVD1N4003ST	DIODE , RECT	1N4003	1	EA
D105	CVD1N4003ST	DIODE , RECT	1N4003	1	EA
D108	CVD1N4003ST	DIODE , RECT	1N4003	1	EA
D109	CVDZJ8.2BT	DIODE , ZENER	ZJ8.2B 1/2W	1	EA
D111	CVDZJ8.2BT	DIODE , ZENER	ZJ8.2B 1/2W	1	EA
D114	CVD1N4003ST	DIODE , RECT	1N4003	1	EA
D115	CVD1N4003ST	DIODE , RECT	1N4003	1	EA
D116	CVD1N4003ST	DIODE , RECT	1N4003	1	EA
D117	CVD1N4003ST	DIODE , RECT	1N4003	1	EA
D124	CVD1N4003ST	DIODE , RECT	1N4003	1	EA
D125	CVD1N4003ST	DIODE , RECT	1N4003	1	EA
D801	CVD1SS133MT	DIODE	1SS133	1	EA
D802	CVD1SS133MT	DIODE	1SS133	1	EA
Q104	HVTKSC2316YT	TRANSISTOR NPN	KSC2316Y	1	EA
Q911	HVTKTA1267YT	TRANSISTOR PNP	KTA1267Y	1	EA
Q912	HVTKTC3198YT	TRANSISTOR NPN	KTC3198Y	1	EA
Q913	HVTKTC3198YT	TRANSISTOR NPN	KTC3198Y	1	EA
D991	HVDKBU804F	DIODE , BRIDGE	DIODE(KBU804F)	1	EA
D992	HVDKBU804F	DIODE , BRIDGE	DIODE(KBU804F)	1	EA
IC89	HVIKIA278R05PI	REGULATOR (5V OUTPUT LOW DROP)	KEC(KIA278R05PI)	1	EA
IC90	CVIKIA278R15PI	I.C , REGULATOR(15V OUTPUT LOW DROF	KEC(KIA278R15PI)	1	EA
IC91	CVIKIA7915PI	I.C , REGULATOR(15V, TO-220AB)	KEC(KIA7915PI)	1	EA
IC93	CVIKIA7905PI	I.C , REGULATOR(-5V)	KEC(KIA7905PI)	1	EA
IC94	HVIKIA7809API	I.C , REGULATOR +9V	KEC(KIA7809API)	1	EA
Q852	HVTKTD600KGR	TRANSISTOR , BIAS NPN	KTD600KGR	1	EA
Q853	HVTKTD600KGR	TRANSISTOR , BIAS NPN	KTD600KGR	1	EA
Q854	HVTKTD600KGR	TRANSISTOR , BIAS NPN	KTD600KGR	1	EA
Q855	HVTKTD600KGR	TRANSISTOR , BIAS NPN	KTD600KGR	1	EA
Q856	HVTKTD600KGR	TRANSISTOR , BIAS NPN	KTD600KGR	1	EA
<i>Resistors</i>					
R101	CRD25FJ3R3T	RES , CARBON	3.3 OHM 1/4W J	1	EA
R108	CRD20TJ8R2T	RES , CARBON	8.2 OHM 1/5W J	1	EA
R109	CRD20TJ100T	RES , CARBON	10 OHM 1/5W J	1	EA
R110	CRD20TJ8R2T	RES , CARBON	8.2 OHM 1/5W J	1	EA
R112	CRD20TJ122T	RES , CARBON	1.2K OHM 1/5W J	1	EA
R113	CRD20TJ473T	RES , CARBON	47K OHM 1/5W J	1	EA
R120	CRD20TJ103T	RES , CARBON	10K OHM 1/5W J	1	EA
R121	CRD20TJ104T	RES , CARBON	100K OHM 1/5W J	1	EA
R122	CRD20TJ104T	RES , CARBON	100K OHM 1/5W J	1	EA
R750	CRD20TJ103T	RES , CARBON	10K OHM 1/5W J	1	EA
R751	CRD20TJ103T	RES , CARBON	10K OHM 1/5W J	1	EA
R875	CRD20TJ331T	RES , CARBON	330 OHM 1/5W J	1	EA
R876	CRD20TJ331T	RES , CARBON	330 OHM 1/5W J	1	EA
R877	CRD20TJ331T	RES , CARBON	330 OHM 1/5W J	1	EA
R878	CRD20TJ331T	RES , CARBON	330 OHM 1/5W J	1	EA
R879	CRD20TJ331T	RES , CARBON	330 OHM 1/5W J	1	EA
R883	CRD20TJ122T	RES , CARBON	1.2K OHM 1/5W J	1	EA
R884	CRD20TJ122T	RES , CARBON	1.2K OHM 1/5W J	1	EA
R885	CRD20TJ122T	RES , CARBON	1.2K OHM 1/5W J	1	EA
R886	CRD20TJ122T	RES , CARBON	1.2K OHM 1/5W J	1	EA
R887	CRD20TJ122T	RES , CARBON	1.2K OHM 1/5W J	1	EA
R891	CRD20TJ391T	RES , CARBON	390 OHM 1/5W J	1	EA
R893	CRD20TJ391T	RES , CARBON	390 OHM 1/5W J	1	EA
R894	CRD20TJ391T	RES , CARBON	390 OHM 1/5W J	1	EA
R895	CRD20TJ391T	RES , CARBON	390 OHM 1/5W J	1	EA
R896	CRD20TJ391T	RES , CARBON	390 OHM 1/5W J	1	EA
R901	CRD20TJ272T	RES , CARBON	2.7K OHM 1/5W J	1	EA
R912	CRD20TJ153T	RES , CARBON	15K OHM 1/5W J	1	EA

Ref. Designator	Part Number	Description		Qty	
PCB , POWER TRANS/DOWNLOAD/DIG IN/OUT		CUP12101			
R913	CRD20TJ153T	RES , CARBON	15K OHM 1/5W J	1	EA
R917	CRD20TJ153T	RES , CARBON	15K OHM 1/5W J	1	EA
R918	CRD20TJ153T	RES , CARBON	15K OHM 1/5W J	1	EA
R919	CRD20TJ153T	RES , CARBON	15K OHM 1/5W J	1	EA
R920	CRD20TJ153T	RES , CARBON	15K OHM 1/5W J	1	EA
R921	CRD20TJ153T	RES , CARBON	15K OHM 1/5W J	1	EA
R922	CRD20TJ153T	RES , CARBON	15K OHM 1/5W J	1	EA
R923	CRD25TJ153T	RES , CARBON	15K OHM 1/4W J	1	EA
R924	CRD20TJ153T	RES , CARBON	15K OHM 1/5W J	1	EA
R925	CRD20TJ103T	RES , CARBON	10K OHM 1/5W J	1	EA
R926	CRD25TJ103T	RES , CARBON	10K OHM 1/4W J	1	EA
R927	CRD20TJ104T	RES , CARBON	100K OHM 1/5W J	1	EA
R928	CRD20TJ333T	RES , CARBON	33K OHM 1/5W J	1	EA
R941	CRD20TJ104T	RES , CARBON	100K OHM 1/5W J	1	EA
R942	CRD20TJ104T	RES , CARBON	100K OHM 1/5W J	1	EA
VR82	CVN1RA221B02T	RES , SEMI FIXED (220, B CURVE)	KVSF637AVC	1	EA
VR83	CVN1RA221B02T	RES , SEMI FIXED (220, B CURVE)	KVSF637AVC	1	EA
VR84	CVN1RA221B02T	RES , SEMI FIXED (220, B CURVE)	KVSF637AVC	1	EA
VR85	CVN1RA221B02T	RES , SEMI FIXED (220, B CURVE)	KVSF637AVC	1	EA
VR86	CVN1RA221B02T	RES , SEMI FIXED (220, B CURVE)	KVSF637AVC	1	EA
R104	KRQ1AJR47H	RES , FUSE	0.47 OHM 1W J	1	EA
R105	KRQ1AJR47H	RES , FUSE	0.47 OHM 1W J	1	EA
R106	CRQ1AJR33H	RES , FUSE	0.33 OHM 1W J	1	EA
R107	CRQ1AJR33H	RES , FUSE	0.33 OHM 1W J	1	EA
<i>Miscellaneous</i>					
BN17	CJP06GB143ZB	FEMALE HEADER(6P, 2.54mm)	HEADER	1	EA
BN20	CWB1C905120BM	WIRE ASS'Y	WIRE	1	EA
BN43	CWB1C903200BM	WIRE ASS'Y	WIRE	1	EA
BN96	CWB1C909180EN	WIRE ASS'Y(9P, 2MM, 180MM)	WIRE	1	EA
BN97	CWB1C905120EN	WIRE ASS'Y	WIRE	1	EA
CN13	CJP05GA01ZY	WAFER(YMW025-05R)	WAFER	1	EA
CN19	CJP03GA90ZY	WAFER	WAFER	1	EA
CN20	CJP04GA90ZM	WAFER	WAFER	1	EA
CN32	CJP02GA19ZY	WAFER , 2PIN	WAFER	1	EA
CN33	CJP02GA19ZY	WAFER , 2PIN	WAFER	1	EA
CN34	CJP02GA19ZY	WAFER , 2PIN	WAFER	1	EA
CN35	CJP02GA19ZY	WAFER , 2PIN	WAFER	1	EA
CN36	CJP02GA19ZY	WAFER , 2PIN	WAFER	1	EA
CN81	CJP07GA01ZY	WAFER , STRAIGHT(7PIN)	WAFER	1	EA
CN89	CJP02GA01ZY	WAFER , STRAIGHT, 2PIN	WAFER	1	EA
CN96	CJP09GA19ZY	WAFER, STRAIGHT, 9PIN	WAFER	1	EA
CN97	CJP05GA19ZY	WAFER , STRAIGHT	WAFER	1	EA
CN98	HJP08GB131ZK	WAFER	WAFER	1	EA
JK75	HJSTORX177L	MODULE , OPTICAL(RX)	TORX177L	1	EA
JK76	HJSTORX177L	MODULE , OPTICAL(RX)	TORX177L	1	EA
PCB , INPUT		CUP12028			
<i>Capacitors</i>					
C201	CCUS1H221JA	CAP , CHIP	220PF 50V J	1	EA
C202	CCUS1H221JA	CAP , CHIP	220PF 50V J	1	EA
C203	CCUS1H221JA	CAP , CHIP	220PF 50V J	1	EA
C204	CCUS1H221JA	CAP , CHIP	220PF 50V J	1	EA
C205	CCUS1H221JA	CAP , CHIP	220PF 50V J	1	EA
C206	CCUS1H221JA	CAP , CHIP	220PF 50V J	1	EA
C209	CCUS1H221JA	CAP , CHIP	220PF 50V J	1	EA
C210	CCUS1H221JA	CAP , CHIP	220PF 50V J	1	EA
C211	CCUS1H221JA	CAP , CHIP	220PF 50V J	1	EA

Ref. Designator	Part Number	Description		Qty	
PCB , INPUT		CUP12028			
C212	CCUS1H221JA	CAP , CHIP	220PF 50V J	1	EA
C213	CCUS1H221JA	CAP , CHIP	220PF 50V J	1	EA
C214	CCUS1H221JA	CAP , CHIP	220PF 50V J	1	EA
C215	CCUS1H221JA	CAP , CHIP	220PF 50V J	1	EA
C216	CCUS1H221JA	CAP , CHIP	220PF 50V J	1	EA
C219	CCUS1H221JA	CAP , CHIP	220PF 50V J	1	EA
C220	CCUS1H221JA	CAP , CHIP	220PF 50V J	1	EA
C221	CCUS1H221JA	CAP , CHIP	220PF 50V J	1	EA
C222	CCUS1H221JA	CAP , CHIP	220PF 50V J	1	EA
C223	CCUS1H221JA	CAP , CHIP	220PF 50V J	1	EA
C224	CCUS1H221JA	CAP , CHIP	220PF 50V J	1	EA
C260	CCUS1H104KC	CAP , CHIP	0.1UF 50V K	1	EA
C269	CCUS1A105KC	CAP , CHIP	1UF 10V K	1	EA
C274	CCUS1A105KC	CAP , CHIP	1UF 10V K	1	EA
C277	CCUS1H104KC	CAP , CHIP	0.1UF 50V K	1	EA
C279	CCUS1H104KC	CAP , CHIP	0.1UF 50V K	1	EA
C280	CCUS1H104KC	CAP , CHIP	0.1UF 50V K	1	EA
C289	CCUS1H104KC	CAP , CHIP	0.1UF 50V K	1	EA
C290	CCUS1H104KC	CAP , CHIP	0.1UF 50V K	1	EA
C291	CCUS1H104KC	CAP , CHIP	0.1UF 50V K	1	EA
C293	CCUS1H104KC	CAP , CHIP	0.1UF 50V K	1	EA
C301	CCUS1H471JA	CAP , CHIP	470PF 50V J	1	EA
C302	CCUS1H471JA	CAP , CHIP	470PF 50V J	1	EA
C303	CCUS1H471JA	CAP , CHIP	470PF 50V J	1	EA
C304	CCUS1H471JA	CAP , CHIP	470PF 50V J	1	EA
C305	CCUS1H471JA	CAP , CHIP	470PF 50V J	1	EA
C306	CCUS1H471JA	CAP , CHIP	470PF 50V J	1	EA
C309	CCUS1H332KC	CAP , CHIP	3300PF 50V K	1	EA
C310	CCUS1H332KC	CAP , CHIP	3300PF 50V K	1	EA
C311	CCUS1H332KC	CAP , CHIP	3300PF 50V K	1	EA
C312	CCUS1H332KC	CAP , CHIP	3300PF 50V K	1	EA
C313	CCUS1H332KC	CAP , CHIP	3300PF 50V K	1	EA
C314	CCUS1H332KC	CAP , CHIP	3300PF 50V K	1	EA
C317	CCUS1H223KC	CAP , CHIP	0.022UF 50V K	1	EA
C318	CCUS1H223KC	CAP , CHIP	0.022UF 50V K	1	EA
C319	CCUS1H223KC	CAP , CHIP	0.022UF 50V K	1	EA
C321	CCUS1H561JA	CAP , CHIP	560PF 50V J	1	EA
C322	CCUS1H561JA	CAP , CHIP	560PF 50V J	1	EA
C323	CCUS1H561JA	CAP , CHIP	560PF 50V J	1	EA
C324	CCUS1H561JA	CAP , CHIP	560PF 50V J	1	EA
C325	CCUS1H561JA	CAP , CHIP	560PF 50V J	1	EA
C326	CCUS1H561JA	CAP , CHIP	560PF 50V J	1	EA
C327	CCUS1H561JA	CAP , CHIP	560PF 50V J	1	EA
C328	CCUS1H561JA	CAP , CHIP	560PF 50V J	1	EA
C329	CCUS1H561JA	CAP , CHIP	560PF 50V J	1	EA
C330	CCUS1H561JA	CAP , CHIP	560PF 50V J	1	EA
C331	CCUS1H561JA	CAP , CHIP	560PF 50V J	1	EA
C332	CCUS1H561JA	CAP , CHIP	560PF 50V J	1	EA
C337	CCUS1H223KC	CAP , CHIP	0.022UF 50V K	1	EA
C338	CCUS1H223KC	CAP , CHIP	0.022UF 50V K	1	EA
C339	CCUS1H223KC	CAP , CHIP	0.022UF 50V K	1	EA
C350	CCUS1H332KC	CAP , CHIP	3300PF 50V K	1	EA
C351	CCUS1H332KC	CAP , CHIP	3300PF 50V K	1	EA
C352	CCUS1H332KC	CAP , CHIP	3300PF 50V K	1	EA
C353	CCUS1H332KC	CAP , CHIP	3300PF 50V K	1	EA
C354	CCUS1H332KC	CAP , CHIP	3300PF 50V K	1	EA
C355	CCUS1H332KC	CAP , CHIP	3300PF 50V K	1	EA
C369	CCUS1H223KC	CAP , CHIP	0.022UF 50V K	1	EA
C370	CCUS1H223KC	CAP , CHIP	0.022UF 50V K	1	EA
C381	CCUS1H223KC	CAP , CHIP	0.022UF 50V K	1	EA
C382	CCUS1H223KC	CAP , CHIP	0.022UF 50V K	1	EA

Ref. Designator	Part Number	Description		Qty	
PCB , INPUT		CUP12028			
C383	CCUS1H223KC	CAP , CHIP	0.022UF 50V K	1	EA
C384	CCUS1H223KC	CAP , CHIP	0.022UF 50V K	1	EA
C385	CCUS1H223KC	CAP , CHIP	0.022UF 50V K	1	EA
C386	CCUS1H223KC	CAP , CHIP	0.022UF 50V K	1	EA
C391	CCUS1H151JA	CAP , CHIP	150PF 50V J	1	EA
C392	CCUS1H151JA	CAP , CHIP	150PF 50V J	1	EA
C393	CCUS1H151JA	CAP , CHIP	150PF 50V J	1	EA
C394	CCUS1H102KC	CAP , CHIP	1000PF 50V K	1	EA
C395	CCUS1H151JA	CAP , CHIP	150PF 50V J	1	EA
C396	CCUS1H151JA	CAP , CHIP	150PF 50V J	1	EA
C601	CCUS1H104KC	CAP , CHIP	0.1UF 50V K	1	EA
C603	CCUS1H104KC	CAP , CHIP	0.1UF 50V K	1	EA
C605	CCUS1H104KC	CAP , CHIP	0.1UF 50V K	1	EA
C607	CCUS1H104KC	CAP , CHIP	0.1UF 50V K	1	EA
C609	CCUS1H104KC	CAP , CHIP	0.1UF 50V K	1	EA
C611	CCUS1H104KC	CAP , CHIP	0.1UF 50V K	1	EA
C613	CCUS1H104KC	CAP , CHIP	0.1UF 50V K	1	EA
C615	CCUS1H104KC	CAP , CHIP	0.1UF 50V K	1	EA
C617	CCUS1H104KC	CAP , CHIP	0.1UF 50V K	1	EA
C619	CCUS1H104KC	CAP , CHIP	0.1UF 50V K	1	EA
C621	CCUS1H104KC	CAP , CHIP	0.1UF 50V K	1	EA
C623	CCUS1H104KC	CAP , CHIP	0.1UF 50V K	1	EA
C625	CCUS1H104KC	CAP , CHIP	0.1UF 50V K	1	EA
C627	CCUS1H104KC	CAP , CHIP	0.1UF 50V K	1	EA
C629	CCUS1H104KC	CAP , CHIP	0.1UF 50V K	1	EA
C631	CCUS1H104KC	CAP , CHIP	0.1UF 50V K	1	EA
C701	CCUS1H150JA	CAP , CHIP	15PF 50V J	1	EA
C702	CCUS1H150JA	CAP , CHIP	15PF 50V J	1	EA
C704	CCUS1H104KC	CAP , CHIP	0.1UF 50V K	1	EA
C705	CCUS1H104KC	CAP , CHIP	0.1UF 50V K	1	EA
C707	CCUS1H102KC	CAP , CHIP	1000PF 50V K	1	EA
C708	CCUS1H104KC	CAP , CHIP	0.1UF 50V K	1	EA
C718	CCUS1H104KC	CAP , CHIP	0.1UF 50V K	1	EA
C719	CCUS1H104KC	CAP , CHIP	0.1UF 50V K	1	EA
C722	CCUS1H104KC	CAP , CHIP	0.1UF 50V K	1	EA
C723	CCUS1H473KC	CAP , CHIP	0.047UF 50V K	1	EA
C725	CCUS1H104KC	CAP , CHIP	0.1UF 50V K	1	EA
C727	CCUS1H104KC	CAP , CHIP	0.1UF 50V K	1	EA
C729	CCUS1H104KC	CAP , CHIP	0.1UF 50V K	1	EA
C731	CCUS1H104KC	CAP , CHIP	0.1UF 50V K	1	EA
C733	CCUS1H104KC	CAP , CHIP	0.1UF 50V K	1	EA
C734	CCUS1H102KC	CAP , CHIP	1000PF 50V K	1	EA
C735	CCUS1H470JA	CAP , CHIP	47PF 50V J	1	EA
C738	CCUS1A105KC	CAP , CHIP	1UF 10V K	1	EA
C739	CCUS1H103KC	CAP , CHIP	0.01UF 50V K	1	EA
C741	CCUS1H104KC	CAP , CHIP	0.1UF 50V K	1	EA
C742	CCUS1H180JA	CAP , CHIP	18PF 50V J	1	EA
C743	CCUS1H104KC	CAP , CHIP	0.1UF 50V K	1	EA
C744	CCUS1H180JA	CAP , CHIP	18PF 50V J	1	EA
C745	CCUS1H104KC	CAP , CHIP	0.1UF 50V K	1	EA
C746	CCUS1H104KC	CAP , CHIP	0.1UF 50V K	1	EA
C747	CCUS1H104KC	CAP , CHIP	0.1UF 50V K	1	EA
C748	CCUS1H104KC	CAP , CHIP	0.1UF 50V K	1	EA
C751	CCUS1H104KC	CAP , CHIP	0.1UF 50V K	1	EA
C757	CCUS1H104KC	CAP , CHIP	0.1UF 50V K	1	EA
C758	CCUS1H104KC	CAP , CHIP	0.1UF 50V K	1	EA
C759	CCUS1H104KC	CAP , CHIP	0.1UF 50V K	1	EA
C760	CCUS1H104KC	CAP , CHIP	0.1UF 50V K	1	EA
C761	CCUS1H104KC	CAP , CHIP	0.1UF 50V K	1	EA
C762	CCUS1H104KC	CAP , CHIP	0.1UF 50V K	1	EA
C763	CCUS1H104KC	CAP , CHIP	0.1UF 50V K	1	EA

Ref. Designator	Part Number	Description		Qty	
PCB , INPUT		CUP12028			
C765	CCUS1H104KC	CAP , CHIP	0.1UF 50V K	1	EA
C768	CCUS1H104KC	CAP , CHIP	0.1UF 50V K	1	EA
C769	CCUS1H104KC	CAP , CHIP	0.1UF 50V K	1	EA
C770	CCUS1H104KC	CAP , CHIP	0.1UF 50V K	1	EA
C771	CCUS1H104KC	CAP , CHIP	0.1UF 50V K	1	EA
C772	CCUS1H104KC	CAP , CHIP	0.1UF 50V K	1	EA
C773	CCUS1H104KC	CAP , CHIP	0.1UF 50V K	1	EA
C775	CCUS1H104KC	CAP , CHIP	0.1UF 50V K	1	EA
C776	CCUS1H473KC	CAP , CHIP	0.047UF 50V K	1	EA
C793	CCUS1H101JA	CAP , CHIP	100PF 50V J	1	EA
C794	CCUS1H181JA	CAP , CHIP	180PF 50V J	1	EA
C795	CCUS1H181JA	CAP , CHIP	180PF 50V J	1	EA
C796	CCUS1H104KC	CAP , CHIP	0.1UF 50V K	1	EA
C797	CCUS1H104KC	CAP , CHIP	0.1UF 50V K	1	EA
C798	CCUS1H104KC	CAP , CHIP	0.1UF 50V K	1	EA
C261	CCEA1EH470T	CAP , ELECT	47UF 25V	1	EA
C262	CCEA1EH470T	CAP , ELECT	47UF 25V	1	EA
C263	CCEA1EH470T	CAP , ELECT	47UF 25V	1	EA
C264	CCEA1EH470T	CAP , ELECT	47UF 25V	1	EA
C265	CCEA1EH470T	CAP , ELECT	47UF 25V	1	EA
C266	CCEA1EH470T	CAP , ELECT	47UF 25V	1	EA
C267	CCEA1EH470T	CAP , ELECT	47UF 25V	1	EA
C268	CCEA1EH470T	CAP , ELECT	47UF 25V	1	EA
C272	CCEA1HH100T	CAP , ELECT	10UF 50V	1	EA
C273	CCEA1HH100T	CAP , ELECT	10UF 50V	1	EA
C275	CCEA1HH100T	CAP , ELECT	10UF 50V	1	EA
C276	CCEA1HH100T	CAP , ELECT	10UF 50V	1	EA
C281	CCEA1HH100T	CAP , ELECT	10UF 50V	1	EA
C282	CCEA1HH100T	CAP , ELECT	10UF 50V	1	EA
C283	CCEA1HH100T	CAP , ELECT	10UF 50V	1	EA
C284	CCEA1HH100T	CAP , ELECT	10UF 50V	1	EA
C285	CCEA1HH100T	CAP , ELECT	10UF 50V	1	EA
C286	CCEA1HH100T	CAP , ELECT	10UF 50V	1	EA
C292	CCEA1CH101T	CAP , ELECT	100UF 16V	1	EA
C294	CCEA1CH101T	CAP , ELECT	100UF 16V	1	EA
C341	CCEA1HH100T	CAP , ELECT	10UF 50V	1	EA
C342	CCEA1HH100T	CAP , ELECT	10UF 50V	1	EA
C343	CCEA1HH100T	CAP , ELECT	10UF 50V	1	EA
C344	CCEA1HH100T	CAP , ELECT	10UF 50V	1	EA
C345	CCEA1HH100T	CAP , ELECT	10UF 50V	1	EA
C346	CCEA1HH100T	CAP , ELECT	10UF 50V	1	EA
C349	CCEA1CH101T	CAP , ELECT	100UF 16V	1	EA
C358	CCEA1CH101T	CAP , ELECT	100UF 16V	1	EA
C359	CCEA1CH101T	CAP , ELECT	100UF 16V	1	EA
C360	CCEA1CH101T	CAP , ELECT	100UF 16V	1	EA
C371	CCEA1HH100T	CAP , ELECT	10UF 50V	1	EA
C372	CCEA1HH100T	CAP , ELECT	10UF 50V	1	EA
C373	CCEA1HH100T	CAP , ELECT	10UF 50V	1	EA
C374	CCEA1HH100T	CAP , ELECT	10UF 50V	1	EA
C375	CCEA1HH100T	CAP , ELECT	10UF 50V	1	EA
C376	CCEA1HH100T	CAP , ELECT	10UF 50V	1	EA
C389	CCEA1HH100T	CAP , ELECT	10UF 50V	1	EA
C390	CCEA1HH100T	CAP , ELECT	10UF 50V	1	EA
C600	CCEA1CH101T	CAP , ELECT	100UF 16V	1	EA
C602	CCEA1CH101T	CAP , ELECT	100UF 16V	1	EA
C604	CCEA1CH101T	CAP , ELECT	100UF 16V	1	EA
C606	CCEA1CH101T	CAP , ELECT	100UF 16V	1	EA
C608	CCEA1CH101T	CAP , ELECT	100UF 16V	1	EA
C610	CCEA1CH101T	CAP , ELECT	100UF 16V	1	EA
C612	CCEA1CH101T	CAP , ELECT	100UF 16V	1	EA
C614	CCEA1CH101T	CAP , ELECT	100UF 16V	1	EA

Ref. Designator	Part Number	Description		Qty	
PCB , INPUT		CUP12028			
C616	CCEA1CH101T	CAP , ELECT	100UF 16V	1	EA
C618	CCEA1CH101T	CAP , ELECT	100UF 16V	1	EA
C620	CCEA1CH101T	CAP , ELECT	100UF 16V	1	EA
C622	CCEA1CH101T	CAP , ELECT	100UF 16V	1	EA
C624	CCEA1CH101T	CAP , ELECT	100UF 16V	1	EA
C626	CCEA1CH101T	CAP , ELECT	100UF 16V	1	EA
C628	CCEA1CH101T	CAP , ELECT	100UF 16V	1	EA
C630	CCEA1CH101T	CAP , ELECT	100UF 16V	1	EA
C703	CCEA1CH101T	CAP , ELECT	100UF 16V	1	EA
C706	CCEA1CH101T	CAP , ELECT	100UF 16V	1	EA
C717	CCEA1CH101T	CAP , ELECT	100UF 16V	1	EA
C720	CCEA1AH471T	CAP , ELECT	470UF 10V	1	EA
C721	CCEA1AH471T	CAP , ELECT	470UF 10V	1	EA
C724	CCEA1AH471T	CAP , ELECT	470UF 10V	1	EA
C726	CCEA1CH101T	CAP , ELECT	100UF 16V	1	EA
C728	CCEA1AH471T	CAP , ELECT	470UF 10V	1	EA
C730	CCEA1CH101T	CAP , ELECT	100UF 16V	1	EA
C736	CCEA1HH2R2T	CAP , ELECT	2.2UF 50V	1	EA
C737	CCEA1CH101T	CAP , ELECT	100UF 16V	1	EA
C740	CCEA1CH101T	CAP , ELECT	100UF 16V	1	EA
C749	CCEA1CH101T	CAP , ELECT	100UF 16V	1	EA
C764	CCEA0JH102T	CAP , ELECT	1000UF 6.3V	1	EA
C766	CCEA0JH102T	CAP , ELECT	1000UF 6.3V	1	EA
C777	CCEA1CH101T	CAP , ELECT	100UF 16V	1	EA
C732	CCEA0JKR3222E	CAP , ELECT	3300UF 6.3V	1	EA
<i>Semiconductors</i>					
D201	CVD1SS355T	DIODE , CHIP	1SS355T	1	EA
D202	CVD1SS355T	DIODE , CHIP	1SS355T	1	EA
D203	CVD1SS355T	DIODE , CHIP	1SS355T	1	EA
D204	CVD1SS355T	DIODE , CHIP	1SS355T	1	EA
D207	CVD1SS355T	DIODE , CHIP	1SS355T	1	EA
D208	CVD1SS355T	DIODE , CHIP	1SS355T	1	EA
D209	CVD1SS355T	DIODE , CHIP	1SS355T	1	EA
D210	CVD1SS355T	DIODE , CHIP	1SS355T	1	EA
D211	CVD1SS355T	DIODE , CHIP	1SS355T	1	EA
D212	CVD1SS355T	DIODE , CHIP	1SS355T	1	EA
D213	CVD1SS355T	DIODE , CHIP	1SS355T	1	EA
D214	CVD1SS355T	DIODE , CHIP	1SS355T	1	EA
IC20	CVINJW1197CFC2	I.C , VOL WITH INPUT SELECTOR	JRC(NJW1197CFC2)	1	EA
IC21	HVINJM2068MTE1	I.C , DUAL OP AMP	JRC(NJM2068M-TE1)	1	EA
IC22	HVINJM2068MTE1	I.C , DUAL OP AMP	JRC(NJM2068M-TE1)	1	EA
IC23	HVINJM2068MTE1	I.C , DUAL OP AMP	JRC(NJM2068M-TE1)	1	EA
IC25	HVINJM2068MTE1	I.C , DUAL OP AMP	JRC(NJM2068M-TE1)	1	EA
IC31	HVINJM2068MTE1	I.C , DUAL OP AMP	JRC(NJM2068M-TE1)	1	EA
IC32	HVINJM2068MTE1	I.C , DUAL OP AMP	JRC(NJM2068M-TE1)	1	EA
IC33	HVINJM2068MTE1	I.C , DUAL OP AMP	JRC(NJM2068M-TE1)	1	EA
IC71	HVI74HCU04AFNG	I.C , INVERTER	JRC(NJM2068M-TE1)	1	EA
IC72	HVI74HCU04AFNG	I.C , INVERTER	TOSHIBA(TC74HCU04AFNG)	1	EA
IC73	HVIK4589VQ-T	I.C , CODEC + DIR	ASAHI KASEI(AK4589VQ)	1	EA
IC75	CVICS49510-CQ	I.C , DSP	CIRRUS LOGIC(CS49510-CQ)	1	EA
IC76	CVIES29LV800ET70TG	IC , FLASH MEMORY (8Mbit)	EXCEL SEM(ES29LV800ET-70)	1	EA
IC77	HVI57V161610ET7	SDRAM 16M 7NS	HYNIX(HY57V161610ET-7)	1	EA
IC78	HVINJM2391DL133	I.C , CHIP REGULATOR (+3.3V)	JRC(NJM2391DL1-3.3)	1	EA
IC79	CVIKIA1117S18	I.C , REGULATOR(SOT-223)	KEC(KIA1117S18)	1	EA
IC88	CVIKIA1117S33	I.C , REGULATOR(SOT-223)	KEC(KIA1117S33)	1	EA
IC89	CVIM24C32WMN6TP	I.C , EEPROM (32 Kbit)	ST(M24C32WMN6TP)	1	EA
IC90	CVIT5CC1	I.C , FLASH U-COM	TOSHIBA(T5CC1)	1	EA
IC91	HVI74ACT04MTR	I.C , HEX INVERTER	ST(74ACT04MTR)	1	EA
IC94	CVIKIA1117S50	I.C , REGULATOR(SOT-223)	KEC(KIA1117S50)	1	EA

Ref. Designator	Part Number	Description		Qty	
PCB , INPUT		CUP12028			
Q729	HVTKRC107S	TRANSISTOR , CHIP NPN	KRC107S	1	EA
Q730	HVTKRC107S	TRANSISTOR , CHIP NPN	KRC107S	1	EA
D221	CVD1N4003ST	DIODE , RECT	1N4003	1	EA
D222	CVD1N4003ST	DIODE , RECT	1N4003	1	EA
D703	CVD1N4003ST	DIODE , RECT	1N4003	1	EA
D704	CVD1N4003SRT	DIODE , RECT	1N4003	1	EA
IC87	HVIRE5VT28CATZ	I.C , RESET	RESET	1	EA
Q301	HVTKTC2874BT	TRANSISTOR , MUTE NPN	KTC2874B	1	EA
Q302	HVTKTC2874BT	TRANSISTOR , MUTE NPN	KTC2874B	1	EA
Q303	HVTKTC2874BT	TRANSISTOR , MUTE NPN	KTC2874B	1	EA
Q304	HVTKTC2874BT	TRANSISTOR , MUTE NPN	KTC2874B	1	EA
Q305	HVTKTC2874BT	TRANSISTOR , MUTE NPN	KTC2874B	1	EA
Q306	HVTKTC2874BT	TRANSISTOR , MUTE NPN	KTC2874B	1	EA
Q311	HVTKTC2874BT	TRANSISTOR , MUTE NPN	KTC2874B	1	EA
IC36	HVIKIA7808API	I.C , REGULATOR +8V	KIA7808 (KEC)	1	EA
IC37	CVIKIA7908PI	I.C , REGULATOR(TO-220IS)	KIA7908PI TO-220IS	1	EA
<i>Resistors</i>					
RN61	CRJ104DJ103T	RES , 4ARRAY (1608*4)	10K OHM/1608*4	1	EA
RN62	CRJ104DJ103T	RES , 4ARRAY (1608*4)	10K OHM/1608*4	1	EA
RN63	CRJ104DJ103T	RES , 4ARRAY (1608*4)	10K OHM/1608*4	1	EA
RN64	CRJ104DJ101T	RES , 4ARRAY (1608*4)	100 OHM/1608*4	1	EA
RN65	CRJ104DJ101T	RES , 4ARRAY (1608*4)	100 OHM/1608*4	1	EA
RN66	CRJ104DJ101T	RES , 4ARRAY (1608*4)	100 OHM/1608*4	1	EA
RN71	CRJ104DJ103T	RES , 4ARRAY (1608*4)	10K OHM/1608*4	1	EA
RN72	CRJ104DJ103T	RES , 4ARRAY (1608*4)	10K OHM/1608*4	1	EA
RN73	CRJ104DJ103T	RES , 4ARRAY (1608*4)	10K OHM/1608*4	1	EA
RN74	CRJ104DJ330T	RES , 4ARRAY (1608*4)	33 OHM/1608*4	1	EA
RN75	CRJ104DJ330T	RES , 4ARRAY (1608*4)	33 OHM/1608*4	1	EA
RN76	CRJ104DJ330T	RES , 4ARRAY (1608*4)	33 OHM/1608*4	1	EA
RN77	CRJ104DJ330T	RES , 4ARRAY (1608*4)	33 OHM/1608*4	1	EA
RN78	CRJ104DJ330T	RES , 4ARRAY (1608*4)	33 OHM/1608*4	1	EA
RN79	CRJ104DJ330T	RES , 4ARRAY (1608*4)	33 OHM/1608*4	1	EA
RN80	CRJ104DJ330T	RES , 4ARRAY (1608*4)	33 OHM/1608*4	1	EA
RN81	CRJ104DJ330T	RES , 4ARRAY (1608*4)	33 OHM/1608*4	1	EA
RN82	CRJ104DJ330T	RES , 4ARRAY (1608*4)	33 OHM/1608*4	1	EA
RN83	CRJ104DJ330T	RES , 4ARRAY (1608*4)	33 OHM/1608*4	1	EA
RN84	CRJ104DJ330T	RES , 4ARRAY (1608*4)	33 OHM/1608*4	1	EA
RN85	CRJ104DJ330T	RES , 4ARRAY (1608*4)	33 OHM/1608*4	1	EA
RN86	CRJ104DJ103T	RES , 4ARRAY (1608*4)	10K OHM/1608*4	1	EA
RN87	CRJ104DJ330T	RES , 4ARRAY (1608*4)	33 OHM/1608*4	1	EA
RN88	CRJ104DJ103T	RES , 4ARRAY (1608*4)	10K OHM/1608*4	1	EA
RN89	CRJ104DJ103T	RES , 4ARRAY (1608*4)	10K OHM/1608*4	1	EA
RN90	CRJ104DJ330T	RES , 4ARRAY (1608*4)	33 OHM/1608*4	1	EA
RN91	CRJ104DJ330T	RES , 4ARRAY (1608*4)	33 OHM/1608*4	1	EA
RN92	CRJ104DJ101T	RES , 4ARRAY (1608*4)	100 OHM/1608*4	1	EA
R201	CRJ10DJ101T	RES , CHIP	100 OHM	1	EA
R202	CRJ10DJ101T	RES , CHIP	100 OHM	1	EA
R203	CRJ10DJ101T	RES , CHIP	100 OHM	1	EA
R204	CRJ10DJ101T	RES , CHIP	100 OHM	1	EA
R205	CRJ10DJ101T	RES , CHIP	100 OHM	1	EA
R206	CRJ10DJ101T	RES , CHIP	100 OHM	1	EA
R209	CRJ10DJ101T	RES , CHIP	100 OHM	1	EA
R210	CRJ10DJ101T	RES , CHIP	100 OHM	1	EA
R211	CRJ10DJ101T	RES , CHIP	100 OHM	1	EA
R212	CRJ10DJ471T	RES , CHIP	470 OHM	1	EA
R213	CRJ10DJ101T	RES , CHIP	100 OHM	1	EA
R214	CRJ10DJ101T	RES , CHIP	100 OHM	1	EA
R215	CRJ10DJ101T	RES , CHIP	100 OHM	1	EA
R216	CRJ10DJ101T	RES , CHIP	100 OHM	1	EA

Ref. Designator	Part Number	Description		Qty	
PCB , INPUT		CUP12028			
R219	CRJ10DJ101T	RES , CHIP	100 OHM	1	EA
R220	CRJ10DJ101T	RES , CHIP	100 OHM	1	EA
R221	CRJ10DJ101T	RES , CHIP	100 OHM	1	EA
R222	CRJ10DJ101T	RES , CHIP	100 OHM	1	EA
R223	CRJ10DJ101T	RES , CHIP	100 OHM	1	EA
R224	CRJ10DJ272T	RES , CHIP	2.7K OHM	1	EA
R227	CRJ10DJ474T	RES , CHIP	470K OHM	1	EA
R228	CRJ10DJ474T	RES , CHIP	470K OHM	1	EA
R229	CRJ10DJ474T	RES , CHIP	470K OHM	1	EA
R230	CRJ10DJ474T	RES , CHIP	470K OHM	1	EA
R231	CRJ10DJ474T	RES , CHIP	470K OHM	1	EA
R232	CRJ10DJ474T	RES , CHIP	470K OHM	1	EA
R235	CRJ10DJ474T	RES , CHIP	470K OHM	1	EA
R236	CRJ10DJ474T	RES , CHIP	470K OHM	1	EA
R237	CRJ10DJ474T	RES , CHIP	470K OHM	1	EA
R238	CRJ10DJ474T	RES , CHIP	470K OHM	1	EA
R239	CRJ10DJ474T	RES , CHIP	470K OHM	1	EA
R240	CRJ10DJ474T	RES , CHIP	470K OHM	1	EA
R241	CRJ10DJ474T	RES , CHIP	470K OHM	1	EA
R242	CRJ10DJ474T	RES , CHIP	470K OHM	1	EA
R245	CRJ10DJ474T	RES , CHIP	470K OHM	1	EA
R246	CRJ10DJ474T	RES , CHIP	470K OHM	1	EA
R247	CRJ10DJ474T	RES , CHIP	470K OHM	1	EA
R248	CRJ10DJ474T	RES , CHIP	470K OHM	1	EA
R249	CRJ10DJ474T	RES , CHIP	470K OHM	1	EA
R250	CRJ10DJ103T	RES , CHIP	10K OHM	1	EA
R253	CRJ10DJ4R7T	RES , CHIP	4.7 OHM	1	EA
R254	CRJ10DJ4R7T	RES , CHIP	4.7 OHM	1	EA
R256	CRJ10DJ4R7T	RES , CHIP	4.7 OHM	1	EA
R257	CRJ10DJ4R7T	RES , CHIP	4.7 OHM	1	EA
R258	CRJ10DJ4R7T	RES , CHIP	4.7 OHM	1	EA
R259	CRJ10DJ4R7T	RES , CHIP	4.7 OHM	1	EA
R261	CRJ10DJ184T	RES , CHIP	184K OHM	1	EA
R262	CRJ10DJ184T	RES , CHIP	184K OHM	1	EA
R263	CRJ10DJ184T	RES , CHIP	184K OHM	1	EA
R264	CRJ10DJ184T	RES , CHIP	184K OHM	1	EA
R265	CRJ10DJ184T	RES , CHIP	184K OHM	1	EA
R266	CRJ10DJ184T	RES , CHIP	184K OHM	1	EA
R271	CRJ10DJ242T	RES , CHIP	2.4K OHM	1	EA
R272	CRJ10DJ242T	RES , CHIP	2.4K OHM	1	EA
R273	CRJ10DJ242T	RES , CHIP	2.4K OHM	1	EA
R274	CRJ10DJ242T	RES , CHIP	2.2K OHM	1	EA
R275	CRJ10DJ242T	RES , CHIP	2.4K OHM	1	EA
R276	CRJ10DJ242T	RES , CHIP	2.4K OHM	1	EA
R281	CRJ10DJ512T	RES , CHIP	5.1K OHM	1	EA
R282	CRJ10DJ512T	RES , CHIP	5.1K OHM	1	EA
R283	CRJ10DJ512T	RES , CHIP	5.1K OHM	1	EA
R284	CRJ10DJ912T	RES , CHIP	9.1K OHM	1	EA
R285	CRJ10DJ512T	RES , CHIP	5.1K OHM	1	EA
R286	CRJ10DJ512T	RES , CHIP	5.1K OHM	1	EA
R291	CRJ10DJ184T	RES , CHIP	180K OHM	1	EA
R292	CRJ10DJ184T	RES , CHIP	180K OHM	1	EA
R293	CRJ10DJ184T	RES , CHIP	180K OHM	1	EA
R294	CRJ10DJ184T	RES , CHIP	180K OHM	1	EA
R295	CRJ10DJ184T	RES , CHIP	180K OHM	1	EA
R296	CRJ10DJ184T	RES , CHIP	180K OHM	1	EA
R301	CRJ10DJ332T	RES , CHIP	3.3K OHM	1	EA
R302	CRJ10DJ332T	RES , CHIP	3.3K OHM	1	EA
R303	CRJ10DJ332T	RES , CHIP	3.3K OHM	1	EA
R304	CRJ10DJ332T	RES , CHIP	3.3K OHM	1	EA
R305	CRJ10DJ332T	RES , CHIP	3.3K OHM	1	EA

Ref. Designator	Part Number	Description		Qty	
PCB , INPUT		CUP12028			
R306	CRJ10DJ332T	RES , CHIP	3.3K OHM	1	EA
R307	CRJ10DJ332T	RES , CHIP	3.3K OHM	1	EA
R308	CRJ10DJ332T	RES , CHIP	3.3K OHM	1	EA
R309	CRJ10DJ332T	RES , CHIP	3.3K OHM	1	EA
R310	CRJ10DJ332T	RES , CHIP	3.3K OHM	1	EA
R311	CRJ10DJ332T	RES , CHIP	3.3K OHM	1	EA
R312	CRJ10DJ332T	RES , CHIP	3.3K OHM	1	EA
R317	CRJ10DJ561T	RES , CHIP	560 OHM	1	EA
R318	CRJ10DF3920T	RES. CHIP (392R 1%)	3.9K OHM	1	EA
R321	CRJ10DJ512T	RES , CHIP	5.1 OHM	1	EA
R322	CRJ10DJ122T	RES , CHIP	1.2 OHM	1	EA
R323	CRJ10DJ122T	RES , CHIP	1.2 OHM	1	EA
R324	CRJ10DJ512T	RES , CHIP	5.1 OHM	1	EA
R325	CRJ10DJ512T	RES , CHIP	5.1 OHM	1	EA
R326	CRJ10DJ122T	RES , CHIP	1.2 OHM	1	EA
R327	CRJ10DJ122T	RES , CHIP	1.2 OHM	1	EA
R328	CRJ10DJ103T	RES , CHIP	10K OHM	1	EA
R329	CRJ10DJ512T	RES , CHIP	5.1K OHM	1	EA
R330	CRJ10DJ122T	RES , CHIP	1.2K OHM	1	EA
R331	CRJ10DJ122T	RES , CHIP	1.2K OHM	1	EA
R332	CRJ10DJ512T	RES , CHIP	5.1K OHM	1	EA
R341	CRJ10DJ122T	RES , CHIP	1.2K OHM	1	EA
R344	CRJ10DJ122T	RES , CHIP	1.2K OHM	1	EA
R345	CRJ10DJ122T	RES , CHIP	1.2K OHM	1	EA
R348	CRJ10DJ122T	RES , CHIP	1.2K OHM	1	EA
R349	CRJ10DJ122T	RES , CHIP	1.2K OHM	1	EA
R352	CRJ10DJ122T	RES , CHIP	1.2K OHM	1	EA
R361	CRJ10DJ104T	RES , CHIP	100K OHM	1	EA
R362	CRJ10DJ104T	RES , CHIP	100K OHM	1	EA
R363	CRJ10DJ104T	RES , CHIP	100K OHM	1	EA
R364	CRJ10DJ104T	RES , CHIP	100K OHM	1	EA
R365	CRJ10DJ104T	RES , CHIP	100K OHM	1	EA
R366	CRJ10DJ104T	RES , CHIP	100K OHM	1	EA
R371	CRJ10DJ512T	RES , CHIP	5.1K OHM	1	EA
R372	CRJ10DJ512T	RES , CHIP	5.1K OHM	1	EA
R373	CRJ10DJ512T	RES , CHIP	5.1K OHM	1	EA
R374	CRJ10DJ103T	RES , CHIP	10K OHM	1	EA
R375	CRJ10DJ512T	RES , CHIP	5.1K OHM	1	EA
R376	CRJ10DJ512T	RES , CHIP	5.1K OHM	1	EA
R381	CRJ10DJ561T	RES , CHIP	560 OHM	1	EA
R382	CRJ10DJ561T	RES , CHIP	560 OHM	1	EA
R383	CRJ10DJ561T	RES , CHIP	560 OHM	1	EA
R384	CRJ10DJ561T	RES , CHIP	560 OHM	1	EA
R385	CRJ10DJ561T	RES , CHIP	560 OHM	1	EA
R386	CRJ10DJ561T	RES , CHIP	560 OHM	1	EA
R389	CRJ10DJ184T	RES , CHIP	180K OHM	1	EA
R390	CRJ10DJ184T	RES , CHIP	180K OHM	1	EA
R391	CRJ10DF3920T	RES. CHIP (392R 1%)	3.9K OHM	1	EA
R392	CRJ10DF3920T	RES. CHIP (392R 1%)	3.9K OHM	1	EA
R393	CRJ10DF3920T	RES. CHIP (392R 1%)	3.9K OHM	1	EA
R394	CRJ10DF3920T	RES. CHIP (392R 1%)	3.9K OHM	1	EA
R395	CRJ10DF3920T	RES. CHIP (392R 1%)	3.9K OHM	1	EA
R396	CRJ10DF3920T	RES. CHIP (392R 1%)	3.9K OHM	1	EA
R701	CRJ10DJ103T	RES , CHIP	10K OHM	1	EA
R702	CRJ10DJ103T	RES , CHIP	10K OHM	1	EA
R709	CRJ10DJ103T	RES , CHIP	10K OHM	1	EA
R710	CRJ10DJ103T	RES , CHIP	10K OHM	1	EA
R712	CRJ10DJ103T	RES , CHIP	10K OHM	1	EA
R714	CRJ10DJ104T	RES , CHIP	100K OHM	1	EA
R715	CRJ10DJ104T	RES , CHIP	100K OHM	1	EA
R716	CRJ10DJ472T	RES , CHIP	4.7K OHM	1	EA

Ref. Designator	Part Number	Description		Qty	
PCB , INPUT		CUP12028			
R717	CRJ10DJ3R3T	RES , CHIP	3.3K OHM	1	EA
R718	CRJ10DJ123T	RES , CHIP	3.3K OHM	1	EA
R719	CRJ10DJ473T	RES , CHIP	47K OHM	1	EA
R720	CRJ10DJ473T	RES , CHIP	47K OHM	1	EA
R721	CRJ10DJ330T	RES , CHIP	33 OHM	1	EA
R723	CRJ10DJ2R7T	RES , CHIP	2.7 OHM	1	EA
R724	CRJ10DJ101T	RES , CHIP	100 OHM	1	EA
R725	CRJ10DJ473T	RES , CHIP	47K OHM	1	EA
R726	CRJ10DJ473T	RES , CHIP	47K OHM	1	EA
R727	CRJ10DJ473T	RES , CHIP	47K OHM	1	EA
R728	CRJ10DJ102T	RES , CHIP	1K OHM	1	EA
R729	CRJ10DJ123T	RES , CHIP	12K OHM	1	EA
R730	CRJ10DJ123T	RES , CHIP	12K OHM	1	EA
R733	CRJ10DJ100T	RES , CHIP	10 OHM	1	EA
R736	CRJ10DJ241T	RES , CHIP	240 OHM	1	EA
R737	CRJ10DJ330T	RES , CHIP	33 OHM	1	EA
R739	CRJ10DJ1R0T	RES , CHIP	1 OHM	1	EA
R740	CRJ10DJ820T	RES , CHIP	82 OHM	1	EA
R741	CRJ10DJ330T	RES , CHIP	33 OHM	1	EA
R742	CRJ10DJ330T	RES , CHIP	33 OHM	1	EA
R743	CRJ10DJ330T	RES , CHIP	33 OHM	1	EA
R744	CRJ10DJ0R0T	RES , CHIP	0 OHM	1	EA
R746	CRJ10DJ0R0T	RES , CHIP	0 OHM	1	EA
R747	CRJ10DJ330T	RES , CHIP	33 OHM	1	EA
R748	CRJ10DJ330T	RES , CHIP	33 OHM	1	EA
R751	CRJ10DJ330T	RES , CHIP	33 OHM	1	EA
R752	CRJ10DJ330T	RES , CHIP	33 OHM	1	EA
R753	CRJ10DJ103T	RES , CHIP	100K OHM	1	EA
R754	CRJ10DJ103T	RES , CHIP	100K OHM	1	EA
R755	CRJ10DJ750T	RES , CHIP	75 OHM	1	EA
R756	CRJ10DJ103T	RES , CHIP	100K OHM	1	EA
R757	CRJ10DJ750T	RES , CHIP	75 OHM	1	EA
R759	CRJ10DJ330T	RES , CHIP	33 OHM	1	EA
R760	CRJ10DJ105T	RES , CHIP	1M OHM	1	EA
R761	CRJ10DJ104T	RES , CHIP	1K OHM	1	EA
R762	CRJ10DJ104T	RES , CHIP	1K OHM	1	EA
R763	CRJ10DJ472T	RES , CHIP	4.7K OHM	1	EA
R764	CRJ10DJ472T	RES , CHIP	4.7K OHM	1	EA
R765	CRJ10DJ103T	RES , CHIP	100K OHM	1	EA
R766	CRJ10DJ103T	RES , CHIP	100K OHM	1	EA
R767	CRJ10DJ301T	RES , CHIP	300 OHM	1	EA
R768	CRJ10DJ562T	RES , CHIP	5.6K OHM	1	EA
R771	CRJ10DJ0R0T	RES , CHIP	0 OHM	1	EA
R773	CRJ10DJ332T	RES , CHIP	3.3K OHM	1	EA
R774	CRJ10DJ332T	RES , CHIP	3.3K OHM	1	EA
R775	CRJ10DJ332T	RES , CHIP	3.3K OHM	1	EA
R776	CRJ10DJ332T	RES , CHIP	3.3K OHM	1	EA
R777	CRJ10DJ102T	RES , CHIP	1K OHM	1	EA
R778	CRJ10DJ103T	RES , CHIP	10K OHM	1	EA
R779	CRJ10DJ102T	RES , CHIP	1K OHM	1	EA
R780	CRJ10DJ102T	RES , CHIP	1K OHM	1	EA
R781	CRJ10DJ750T	RES , CHIP	75 OHM	1	EA
R782	CRJ10DJ272T	RES , CHIP	2.7 OHM	1	EA
R783	CRJ10DJ272T	RES , CHIP	2.7 OHM	1	EA
R784	CRJ10DJ473T	RES , CHIP	47K OHM	1	EA
R785	CRJ10DJ104T	RES , CHIP	100K OHM	1	EA
R786	CRJ10DJ471T	RES , CHIP	470 OHM	1	EA
R787	CRJ10DJ103T	RES , CHIP	10K OHM	1	EA
R788	CRJ10DJ103T	RES , CHIP	10K OHM	1	EA
R789	CRJ10DJ103T	RES , CHIP	10K OHM	1	EA
R790	CRJ10DJ103T	RES , CHIP	10K OHM	1	EA

Ref. Designator	Part Number	Description		Qty	
PCB , INPUT		CUP12028			
R792	CRJ10DJ103T	RES , CHIP	10K OHM	1	EA
R794	CRJ10DJ102T	RES , CHIP	1K OHM	1	EA
R795	CRJ10DJ102T	RES , CHIP	1K OHM	1	EA
R796	CRJ10DJ102T	RES , CHIP	1K OHM	1	EA
<i>Miscellaneous</i>					
X702	HOX27000E180S	CRYSTAL , CHIP(27MHZ,SMD)	27MHz	1	EA
L701	CLZ9Z014Z	FERRITE , CHIP BEAD(60ohm, 4516)	HCB4516KF-600T60	1	EA
L702	CLZ9Z014Z	FERRITE , CHIP BEAD(60ohm, 4516)	HCB4516KF-600T60	1	EA
L703	CLZ9Z014Z	FERRITE , CHIP BEAD(60ohm, 4516)	HCB4516KF-600T60	1	EA
L704	CLZ9R005Z	FERRITE , CHIP BEAD(60ohm, 1608)	HCB1608KF-600T30	1	EA
L705	CLZ9R005Z	FERRITE , CHIP BEAD(60ohm, 1608)	HCB1608KF-600T30	1	EA
BN46	CWZAVR154BN46	SHIELD WIRE ASS'Y	WIRE	1	EA
CN10	CJP05GB46ZY	WAFER	WAFER	1	EA
CN11	CJP13GA117ZY	WAFER , CARD CABLE	WAFER	1	EA
CN12	CJP21GA115ZY	WAFER , CARD CABLE	WAFER	1	EA
CN13	CJP13GA115ZY	WAFER , CARD CABLE	WAFER	1	EA
CN14	CJP13GA117ZY	WAFER , CARD CABLE	WAFER	1	EA
CN17	CJP06GB142ZB	PIN HEADER(6P, 2.54mm)	HEADER	1	EA
CN18	CJP05GA19ZY	WAFER , STRAIGHT	WAFER	1	EA
CN19	CJP07GA117ZY	WAFER	WAFER	1	EA
CN20	CJP05GA01ZY	WAFER(YMW025-05R)	WAFER	1	EA
CN22	CJP07GA19ZY	WAFER , STRAIGHT(7PIN)	WAFER	1	EA
CN72	CJP17GA117ZY	WAFER	WAFER	1	EA
JK11	CJJ4R019W	TERMINAL , IN/OUT	JACK	1	EA
JK12	CJJ4P014W	JACK , IN/OUT	JACK	1	EA
JK13	CJJ4R019W	TERMINAL , IN/OUT	JACK	1	EA
JK14	CJJ4P043W	JACK IN/OUT	JACK	1	EA
JK78	CJJ4S022Z	JACK , BOARD	JACK	1	EA
X701	HOX24576E150TF	CRYSTAL	24.576MHZ	1	EA
PCB , VIDEO		CUP12030			
<i>Capacitors</i>					
C401	CCBS1H101KBT	CAP , CERAMIC(100PF/50V)	100PF 50V	1	EA
C402	CCBS1H101KBT	CAP , CERAMIC(100PF/50V)	100PF 50V	1	EA
C403	CCBS1H101KBT	CAP , CERAMIC(100PF/50V)	100PF 50V	1	EA
C406	CCEA1HKS1R0T	CAP , ELECT	1UF 50V SMALL SIZE	1	EA
C407	CCBS1H104ZFT	CAP , CERAMIC	0.1UF 50V Z	1	EA
C411	CCEA1HH100T	CAP , ELECT	10UF 50V	1	EA
C412	CCEA1HH100T	CAP , ELECT	10UF 50V	1	EA
C413	CCEA1HH100T	CAP , ELECT	10UF 50V	1	EA
C421	CCEA1HH100T	CAP , ELECT	10UF 50V	1	EA
C422	CCEA1HH100T	CAP , ELECT	10UF 50V	1	EA
C423	CCEA1HH100T	CAP , ELECT	10UF 50V	1	EA
C451	CCEA1HH100T	CAP , ELECT	10UF 50V	1	EA
C452	CCEA1HH100T	CAP , ELECT	10UF 50V	1	EA
C453	CCEA1HH100T	CAP , ELECT	10UF 50V	1	EA
C461	CCBS1H223ZFT	CAP , CERAMIC(22000PF/50V)	0.022UF 50V	1	EA
C462	CCEA1CH101T	CAP , ELECT	100UF 16V	1	EA
C463	CCBS1H223ZFT	CAP , CERAMIC(22000PF/50V)	0.022UF 50V	1	EA
C464	CCEA1CH101T	CAP , ELECT	100UF 16V	1	EA
C466	CCBS1H223ZFT	CAP , CERAMIC(22000PF/50V)	0.022UF 50V	1	EA
C467	CCEA1CH101T	CAP , ELECT	100UF 16V	1	EA
C468	CCBS1H223ZFT	CAP , CERAMIC(22000PF/50V)	0.022UF 50V	1	EA
C469	CCEA1CH101T	CAP , ELECT	100UF 16V	1	EA
C471	CCBS1H223ZFT	CAP , CERAMIC(22000PF/50V)	0.022UF 50V	1	EA
C472	CCEA1CH101T	CAP , ELECT	100UF 16V	1	EA
C473	CCBS1H223ZFT	CAP , CERAMIC(22000PF/50V)	0.022UF 50V	1	EA

Ref. Designator	Part Number	Description		Qty	
PCB , VIDEO		CUP12030			
C474	CCEA1CH101T	CAP , ELECT	100UF 16V	1	EA
C481	CCBS1H101KBT	CAP , CERAMIC(100PF/50V)	100PF 50V	1	EA
C483	CCBS1H101KBT	CAP , CERAMIC(100PF/50V)	100PF 50V	1	EA
C491	CCBS1H101KBT	CAP , CERAMIC(100PF/50V)	100PF 50V	1	EA
C492	CCBS1H101KBT	CAP , CERAMIC(100PF/50V)	100PF 50V	1	EA
C493	CCBS1H101KBT	CAP , CERAMIC(100PF/50V)	100PF 50V	1	EA
C500	CCBS1H104ZFT	CAP , CERAMIC	0.1UF 50V Z	1	EA
C501	CCBS1E103ZFT	CAP , CERAMIC(10000PF/25V)	0.01F 50V	1	EA
C503	CCEA1HH100T	CAP , ELECT	10UF 50V	1	EA
C504	CCBS1H104ZFT	CAP , CERAMIC	0.1UF 50V Z	1	EA
C505	CCEA1HH100T	CAP , ELECT	10UF 50V	1	EA
C511	CCBS1E103ZFT	CAP , CERAMIC(10000PF/25V)	0.01F 50V	1	EA
C513	CCEA1HKS1R0T	CAP , ELECT	1UF 50V SMALL SIZE	1	EA
C514	CCEA1HH100T	CAP , ELECT	10UF 50V	1	EA
C515	CCEA1HH100T	CAP , ELECT	10UF 50V	1	EA
C521	CCBS1H223ZFT	CAP , CERAMIC(22000PF/50V)	0.022UF 50V	1	EA
C522	CCEA1CH101T	CAP , ELECT	100UF 16V	1	EA
C524	CCEA1CH101T	CAP , ELECT	100UF 16V	1	EA
C525	CCBS1H223ZFT	CAP , CERAMIC(22000PF/50V)	0.022UF 50V	1	EA
C531	CCBS1H223ZFT	CAP , CERAMIC(22000PF/50V)	0.022UF 50V	1	EA
C532	CCEA1CH101T	CAP , ELECT	100UF 16V	1	EA
C533	CCEA1CH101T	CAP , ELECT	100UF 16V	1	EA
C534	CCEA1CH101T	CAP , ELECT	100UF 16V	1	EA
C535	CCBS1H223ZFT	CAP , CERAMIC(22000PF/50V)	0.022UF 50V	1	EA
C536	CCEA1AH471T	CAP , ELECT	470UF 10V	1	EA
C537	CCEA1CH101T	CAP , ELECT	100UF 16V	1	EA
C538	CCEA1CH101T	CAP , ELECT	100UF 16V	1	EA
C539	CCBS1H104ZFT	CAP , CERAMIC	0.1UF 50V Z	1	EA
C543	CCBS1H104ZFT	CAP , CERAMIC	0.1UF 50V Z	1	EA
C544	CCEA1CH101T	CAP , ELECT	100UF 16V	1	EA
C548	CCBS1H104ZFT	CAP , CERAMIC	0.1UF 50V Z	1	EA
C549	CCEA1CH101T	CAP , ELECT	100UF 16V	1	EA
C552	CCBS1H223ZFT	CAP , CERAMIC(22000PF/50V)	0.022UF 50V	1	EA
C553	CCBS1H223ZFT	CAP , CERAMIC(22000PF/50V)	0.022UF 50V	1	EA
C554	CCBS1H223ZFT	CAP , CERAMIC(22000PF/50V)	0.022UF 50V	1	EA
C555	CCBS1C272MXT	CAP , CERAMIC(2700PF/16V)	2700PF 16V	1	EA
C559	CCEA1HH1R0T	CAP , ELECT	1UF 50V	1	EA
C601	CCBS1H220JCT	CAP , CERAMIC(22PF/50V)	22 PF 50V	1	EA
C602	CCEA0JH102T	CAP , ELECT	1000UF 6.3V	1	EA
C603	CCBS1H220JCT	CAP , CERAMIC(22PF/50V)	22 PF 50V	1	EA
C604	CCEA0JH102T	CAP , ELECT	1000UF 6.3V	1	EA
C605	CCBS1H220JCT	CAP , CERAMIC(22PF/50V)	22 PF 50V	1	EA
C606	CCEA0JH102T	CAP , ELECT	1000UF 6.3V	1	EA
C611	CCBS1H220JCT	CAP , CERAMIC(22PF/50V)	22 PF 50V	1	EA
C612	CCEA1HH100T	CAP , ELECT	10UF 50V	1	EA
C613	CCBS1H220JCT	CAP , CERAMIC(22PF/50V)	22 PF 50V	1	EA
C614	CCEA1HH100T	CAP , ELECT	10UF 50V	1	EA
C615	CCBS1H220JCT	CAP , CERAMIC(22PF/50V)	22 PF 50V	1	EA
C616	CCEA1HH100T	CAP , ELECT	10UF 50V	1	EA
C621	CCBS1H220JCT	CAP , CERAMIC(22PF/50V)	22 PF 50V	1	EA
C622	CCEA1HH100T	CAP , ELECT	10UF 50V	1	EA
C623	CCBS1H220JCT	CAP , CERAMIC(22PF/50V)	22 PF 50V	1	EA
C624	CCEA1HH100T	CAP , ELECT	10UF 50V	1	EA
C625	CCBS1H220JCT	CAP , CERAMIC(22PF/50V)	22 PF 50V	1	EA
C626	CCEA1HH100T	CAP , ELECT	10UF 50V	1	EA
C671	CCEA1CH101T	CAP , ELECT	100UF 16V	1	EA
C672	CCBS1H104ZFT	CAP , CERAMIC	0.1UF 50V Z	1	EA
C673	CCEA1HH100T	CAP , ELECT	10UF 50V	1	EA
C701	CCBS1H330JT	CAP , CERAMIC(33PF/50V)	33 PF 50V	1	EA
C702	CCBS1H330JT	CAP , CERAMIC(33PF/50V)	33 PF 50V	1	EA
C705	CCBS1H181KBT	CAP , CERAMIC(180PF/50V)	180 PF 50V	1	EA

Ref. Designator	Part Number	Description		Qty	
PCB , VIDEO		CUP12030			
C708	CCEA1HHR47T	CAP , ELECT	0.47UF 50V	1	EA
C711	CCEA1AH471T	CAP , ELECT	470UF 10V	1	EA
C717	CCBS1H220JCT	CAP , CERAMIC(22PF/50V)	22PF 50V	1	EA
C721	CCBS1H560JT	CAP , CERAMIC(56PF/50V)	56PF 10V	1	EA
C722	CCBS1H220JCT	CAP , CERAMIC(22PF/50V)	22PF 50V	1	EA
C723	CCEA1HH0R1T	CAP , ELECT	0.1UF 50V	1	EA
C725	HCQ11H682JZT	CAP , MYLAR	6800PF 50V J	1	EA
C726	CCEA1HKS1R0T	CAP , ELECT	1UF 50V SMALL SIZE	1	EA
C731	CCBS1H220JCT	CAP , CERAMIC(22PF/50V)	22PF 50V	1	EA
C732	CCBS1H330JT	CAP , CERAMIC(33PF/50V)	33PF 50V	1	EA
C733	CCBS1H223ZFT	CAP , CERAMIC(22000PF/50V)	0.022UF 50V	1	EA
C734	CCEA1HH1R0T	CAP , ELECT	1UF 50V	1	EA
C736	CCBS1H223ZFT	CAP , CERAMIC(22000PF/50V)	0.022UF 50V	1	EA
C737	CCEA1CH101T	CAP , ELECT	100UF 16V	1	EA
C741	CCBS1H223ZFT	CAP , CERAMIC(22000PF/50V)	0.022UF 50V	1	EA
C712	CCEA0JKR3222E	CAP , ELECT	2200UF 6.3V	1	EA
<i>Semiconductors</i>					
IC41	CVINJM2595MTE1	I.C , VIDEO S/W	JRC(NJM2595MTE1)	1	EA
IC42	CVINJM2595MTE1	I.C , VIDEO S/W	JRC(NJM2595MTE1)	1	EA
IC43	CVINJM2595MTE1	I.C , VIDEO S/W	JRC(NJM2595MTE1)	1	EA
IC51	HVIHCF4053M013T	TRIPLE 2 CHAN ANALOG MULT/ DEMULTIP	ST(HCF4053M013T)	1	EA
IC52	HVIHCF4053M013T	TRIPLE 2 CHAN ANALOG MULT/ DEMULTIP	ST(HCF4053M013T)	1	EA
IC53	CVINJM2587V	6CH VIDEO AMPLIFIER	JRC(NJM2587VTE2)	1	EA
IC54	HVIMM1511XNRE	IC, Y/C-MIX	MITSUMI(MM1511XNRE)	1	EA
IC61	CVINJW1321FP1	I.C , VIDEO S/W	JRC(NJW1321FP1)	1	EA
IC71	HVILC74763M	I.C , OSD	SANYO(LC74763M)	1	EA
IC72	HVI74ACT04MTR	I.C , HEX INVERTER	FARICHILD(74ACT04MTR)	1	EA
D500	CVD1SS133MT	DIODE	1SS133	1	EA
D501	CVD1SS133MT	DIODE	1SS133	1	EA
D502	CVD1SS133MT	DIODE	1SS133	1	EA
D505	CVD1SS133MT	DIODE	1SS133	1	EA
D512	CVD1SS133MT	DIODE	1SS133	1	EA
D514	CVD1SS133MT	DIODE	1SS133	1	EA
D741	CVD1SS133MT	DIODE	1SS133	1	EA
Q501	HVTKSA733CYT	TRANSISTOR PNP	KSA733CYT	1	EA
Q504	HVTKTC2874BT	TRANSISTOR , MUTE NPN	KTC2874B	1	EA
Q505	HVTKRA107MT	TRANSISTOR PNP	KRA107M	1	EA
Q507	HVTKRC107MT	TRANSISTOR NPN	KRC107M	1	EA
Q511	HVTKSA733CYT	TRANSISTOR PNP	KSA733CYT	1	EA
Q512	HVTKRC107MT	TRANSISTOR NPN	KRC107M	1	EA
Q515	HVTKRA107MT	TRANSISTOR PNP	KRA107M	1	EA
Q516	HVTKRC107MT	TRANSISTOR NPN	KRC107M	1	EA
Q517	HVTKRC107MT	TRANSISTOR NPN	KRC107M	1	EA
Q518	HVTKRC107MT	TRANSISTOR NPN	KRC107M	1	EA
Q536	HVTKSA1175YT	TRANSISTOR PNP	KSA1175Y	1	EA
Q551	HVTKTD1302T	TRANSISTOR NPN	KTD1302	1	EA
Q552	HVTKRA104MT	TRANSISTOR PNP	KRA104M	1	EA
Q555	HVTKTD1302T	TRANSISTOR NPN	KTD1302	1	EA
Q556	HVTKRA104MT	TRANSISTOR PNP	KRA104M	1	EA
Q712	HVTKSA1175YT	TRANSISTOR PNP	KSA1175Y	1	EA
Q716	HVTKSC2785YT	TRANSISTOR NPN	KSC2785Y	1	EA
<i>Resistors</i>					
R401	CRD20TJ750T	RES , CARBON	75 OHM 1/5W J	1	EA
R402	CRD20TJ750T	RES , CARBON	75 OHM 1/5W J	1	EA
R403	CRD20TJ750T	RES , CARBON	75 OHM 1/5W J	1	EA
R404	CRD20TJ332T	RES , CARBON	3.3K OHM 1/5W J	1	EA
R405	CRD20TJ332T	RES , CARBON	3.3K OHM 1/5W J	1	EA

Ref. Designator	Part Number	Description		Qty	
PCB , VIDEO		CUP12030			
R411	CRD20TJ750T	RES , CARBON	75 OHM 1/5W J	1	EA
R412	CRD20TJ750T	RES , CARBON	75 OHM 1/5W J	1	EA
R413	CRD20TJ750T	RES , CARBON	75 OHM 1/5W J	1	EA
R421	CRD20TJ750T	RES , CARBON	75 OHM 1/5W J	1	EA
R422	CRD20TJ750T	RES , CARBON	75 OHM 1/5W J	1	EA
R423	CRD20TJ750T	RES , CARBON	75 OHM 1/5W J	1	EA
R451	CRD20TJ750T	RES , CARBON	75 OHM 1/5W J	1	EA
R452	CRD20TJ750T	RES , CARBON	75 OHM 1/5W J	1	EA
R453	CRD20TJ750T	RES , CARBON	75 OHM 1/5W J	1	EA
R461	CRD20TJ102T	RES , CARBON	1K OHM 1/5W J	1	EA
R466	CRD20TJ102T	RES , CARBON	1K OHM 1/5W J	1	EA
R471	CRD20TJ102T	RES , CARBON	1K OHM 1/5W J	1	EA
R491	CRD20TJ750T	RES , CARBON	75 OHM 1/5W J	1	EA
R492	CRD20TJ750T	RES , CARBON	75 OHM 1/5W J	1	EA
R493	CRD20TJ750T	RES , CARBON	75 OHM 1/5W J	1	EA
R500	CRD20TJ4R7T	RES , CARBON	4.7 OHM 1/5W J	1	EA
R501	CRD20TJ333T	RES , CARBON	33K OHM 1/5W J	1	EA
R502	CRD20TJ680T	RES , CARBON	68 OHM 1/5W J	1	EA
R503	CRD20TJ123T	RES , CARBON	12K OHM 1/5W J	1	EA
R504	CRD20TJ223T	RES , CARBON	22K OHM 1/5W J	1	EA
R505	CRD20TJ102T	RES , CARBON	1K OHM 1/5W J	1	EA
R506	CRD20TJ103T	RES , CARBON	10K OHM 1/5W J	1	EA
R507	CRD20TJ103T	RES , CARBON	10K OHM 1/5W J	1	EA
R511	CRD20TJ333T	RES , CARBON	33K OHM 1/5W J	1	EA
R512	CRD20TJ680T	RES , CARBON	68 OHM 1/5W J	1	EA
R513	CRD20TJ123T	RES , CARBON	12K OHM 1/5W J	1	EA
R514	CRD20TJ102T	RES , CARBON	1K OHM 1/5W J	1	EA
R515	CRD20TJ103T	RES , CARBON	10K OHM 1/5W J	1	EA
R516	CRD20TJ103T	RES , CARBON	10K OHM 1/5W J	1	EA
R517	CRD20TJ223T	RES , CARBON	22K OHM 1/5W J	1	EA
R518	CRD20TJ103T	RES , CARBON	10K OHM 1/5W J	1	EA
R519	USE BUSS WIRE	WIRE , COPPER		1	EA
R521	CRD20TJ100T	RES , CARBON	10 OHM 1/5W J	1	EA
R523	CRD20TJ100T	RES , CARBON	10 OHM 1/5W J	1	EA
R531	CRD20TJ100T	RES , CARBON	10 OHM 1/5W J	1	EA
R533	CRD20TJ2R2T	RES , CARBON	2.2 OHM 1/5W J	1	EA
R534	CRD20TJ100T	RES , CARBON	10 OHM 1/5W J	1	EA
R536	CRD20TJ101T	RES , CARBON	100 OHM 1/5W J	1	EA
R537	CRD20TJ183T	RES , CARBON	18K OHM 1/5W J	1	EA
R539	CRD20TJ181T	RES , CARBON	180 OHM 1/5W J	1	EA
R540	CRD20TJ101T	RES , CARBON	100 OHM 1/5W J	1	EA
R541	CRD20TJ181T	RES , CARBON	180 OHM 1/5W J	1	EA
R542	CRD20TJ392T	RES , CARBON	3.9K OHM 1/5W J	1	EA
R543	CRD20TJ1R8T	RES , CARBON	1.8 OHM 1/5W J	1	EA
R545	CRD20TJ181T	RES , CARBON	180 OHM 1/5W J	1	EA
R546	CRD20TJ181T	RES , CARBON	180 OHM 1/5W J	1	EA
R547	CRD20TJ183T	RES , CARBON	18K OHM 1/5W J	1	EA
R548	CRD20TJ1R0T	RES , CARBON	1 OHM 1/5W J	1	EA
R551	CRD20TJ105T	RES , CARBON	1M OHM 1/5W J	1	EA
R552	CRD20TJ223T	RES , CARBON	22K OHM 1/5W J	1	EA
R553	CRD20TJ332T	RES , CARBON	3.3K OHM 1/5W J	1	EA
R555	CRD20TJ562T	RES , CARBON	5.6K OHM 1/5W J	1	EA
R556	CRD20TJ472T	RES , CARBON	4.7K OHM 1/5W J	1	EA
R558	CRD20TJ222T	RES , CARBON	2.2K OHM 1/5W J	1	EA
R581	CRD20TJ4R7T	RES , CARBON	4.7 OHM 1/5W J	1	EA
R582	CRD20TJ101T	RES , CARBON	100 OHM 1/5W J	1	EA
R583	CRD20TJ101T	RES , CARBON	100 OHM 1/5W J	1	EA
R584	CRD20TJ474T	RES , CARBON	470K OHM 1/5W J	1	EA
R585	CRD20TJ474T	RES , CARBON	470K OHM 1/5W J	1	EA
R601	CRD20TJ680T	RES , CARBON	68 OHM 1/5W J	1	EA
R603	CRD20TJ560T	RES , CARBON	56 OHM 1/5W J	1	EA

Ref. Designator	Part Number	Description		Qty	
PCB , VIDEO		CUP12030			
R605	CRD20TJ620T	RES , CARBON	1/5W 62 OHM	1	EA
R611	CRD20TJ750T	RES , CARBON	75 OHM 1/5W J	1	EA
R613	CRD20TJ750T	RES , CARBON	75 OHM 1/5W J	1	EA
R615	CRD20TJ750T	RES , CARBON	75 OHM 1/5W J	1	EA
R621	CRD20TJ750T	RES , CARBON	75 OHM 1/5W J	1	EA
R623	CRD20TJ750T	RES , CARBON	75 OHM 1/5W J	1	EA
R625	CRD20TJ750T	RES , CARBON	75 OHM 1/5W J	1	EA
R641	USE BUSS WIRE	WIRE , COPPER		1	EA
R642	USE BUSS WIRE	WIRE , COPPER		1	EA
R674	CRD20TJ102T	RES , CARBON	1K OHM 1/5W J	1	EA
R675	CRD20TJ102T	RES , CARBON	1K OHM 1/5W J	1	EA
R701	USE BUSS WIRE	WIRE , COPPER		1	EA
R705	CRD20TJ102T	RES , CARBON	1K OHM 1/5W J	1	EA
R706	CRD20TJ102T	RES , CARBON	1K OHM 1/5W J	1	EA
R707	CRD20TJ102T	RES , CARBON	1K OHM 1/5W J	1	EA
R711	CRD20TJ104T	RES , CARBON	100K OHM 1/5W J	1	EA
R712	CRD20TJ103T	RES , CARBON	10K OHM 1/5W J	1	EA
R713	CRD20TJ223T	RES , CARBON	22K OHM 1/5W J	1	EA
R714	CRD20TJ122T	RES , CARBON	1.2K OHM 1/5W J	1	EA
R715	CRD20TJ822T	RES , CARBON	8.2K OHM 1/5W J	1	EA
R716	CRD20TJ103T	RES , CARBON	10K OHM 1/5W J	1	EA
R717	CRD20TJ271T	RES , CARBON	270 OHM 1/5W J	1	EA
R721	CRD20TJ222T	RES , CARBON	2.2K OHM 1/5W J	1	EA
R724	CRD20TJ393T	RES , CARBON	39K OHM 1/5W J	1	EA
R725	CRD20TJ152T	RES , CARBON	1.5K OHM 1/5W J	1	EA
R726	CRD20TJ682T	RES , CARBON	6.8K OHM 1/5W J	1	EA
R727	CRD20TJ102T	RES , CARBON	1K OHM 1/5W J	1	EA
R728	CRD20TJ102T	RES , CARBON	1K OHM 1/5W J	1	EA
R735	CRD20TJ102T	RES , CARBON	1K OHM 1/5W J	1	EA
R737	CRD20TJ104T	RES , CARBON	100K OHM 1/5W J	1	EA
R742	CRD20TJ102T	RES , CARBON	1K OHM 1/5W J	1	EA
R743	CRD20TJ102T	RES , CARBON	1K OHM 1/5W J	1	EA
R744	CRD20TJ102T	RES , CARBON	1K OHM 1/5W J	1	EA
R746	CRD20TJ103T	RES , CARBON	10K OHM 1/5W J	1	EA
R747	CRD20TJ332T	RES , CARBON	3.3K OHM 1/5W J	1	EA
<i>Miscellaneous</i>					
BN14	CJP13GA117ZY	WAFER , CARD CABLE	WAFER	1	EA
BN19	CJP07GA117ZY	WAFER	WAFER	1	EA
CN41	CJP07GA19ZY	WAFER , STRAIGHT(7PIN)	WAFER	1	EA
CN43	CJP03GA01ZY	WAFER	WAFER	1	EA
CN45	CJP07GA117ZY	WAFER	WAFER	1	EA
CN46	CJP03GA19ZY	WAFER , STRAIGHT(3PIN)	WAFER	1	EA
CN47	CJP07GA117ZY	WAFER	WAFER	1	EA
	CWZAVR155JW97	WIRE , ASS'Y	WIRE	1	EA
JK40	CJJ9P003Z	JACK , S-VIDEO+CVBS	JACK	1	EA
JK41	CJJ9R001Z	JACK , S-VIDEO+CVBS	JACK	1	EA
JK43	CJJ2D008Z	JACK , STEREO	JACK	1	EA
JK62	CJJ4R045Z	JACK , BOARD	JACK	1	EA
JK69	CJJ4S030Z	JACK , BOARD	JACK	1	EA
X701	HOX14318E220C	CRYSTAL	14.318Mhz	1	EA
L731	KLQ5R6J405T	COIL , PEAKING(RADIAL)	5.6UH J 4X5	1	EA
L736	HLQ02C101JT	COIL , AXAIL	100UH,J	1	EA
HDMI PCB		(CUP12109)			
<i>Capacitors</i>					
C637	CCUS1H104KC	CAP , CHIP	0.1UF 50V K	1	EA
C901	CCUS1H104KC	CAP , CHIP	0.1UF 50V K	1	EA

Ref. Designator	Part Number	Description		Qty	
HDMI PCB		(CUP12109)			
C903	CCUS1H104KC	CAP , CHIP	0.1UF 50V K	1	EA
C904	CCUS1H104KC	CAP , CHIP	0.1UF 50V K	1	EA
C905	CCUS1H104KC	CAP , CHIP	0.1UF 50V K	1	EA
C906	CCUS1H104KC	CAP , CHIP	0.1UF 50V K	1	EA
C907	CCUS1H104KC	CAP , CHIP	0.1UF 50V K	1	EA
C908	CCUS1H104KC	CAP , CHIP	0.1UF 50V K	1	EA
C909	CCUS1H104KC	CAP , CHIP	0.1UF 50V K	1	EA
C910	CCUS1H104KC	CAP , CHIP	0.1UF 50V K	1	EA
C911	CCUS1A105KC	CAP , CHIP	1UF 10V K	1	EA
C912	CCUS1H104KC	CAP , CHIP	0.1UF 50V K	1	EA
C913	CCUS1H104KC	CAP , CHIP	0.1UF 50V K	1	EA
C914	CCUS1H104KC	CAP , CHIP	0.1UF 50V K	1	EA
C915	CCUS1H104KC	CAP , CHIP	0.1UF 50V K	1	EA
C916	CCUS1H104KC	CAP , CHIP	0.1UF 50V K	1	EA
C917	CCUS1H104KC	CAP , CHIP	0.1UF 50V K	1	EA
C918	CCUS1H104KC	CAP , CHIP	0.1UF 50V K	1	EA
C919	CCUS1H104KC	CAP , CHIP	0.1UF 50V K	1	EA
C920	CCUS1H104KC	CAP , CHIP	0.1UF 50V K	1	EA
C921	CCSJA0J220B	CAP , CHIP TANTAL(A TYPE, ELNA)	22uF/6.3V	1	EA
C922	CCSJA0J220B	CAP , CHIP TANTAL(A TYPE, ELNA)	22uF/6.3V	1	EA
C923	CCSJA0J220B	CAP , CHIP TANTAL(A TYPE, ELNA)	22uF/6.3V	1	EA
C924	CCUS1H104KC	CAP , CHIP	0.1UF 50V K	1	EA
C925	CCUS1H104KC	CAP , CHIP	0.1UF 50V K	1	EA
C926	HCEC1CRV2220T	CAP , CHIP ELECT	22UF/16V	1	EA
C927	CCUS1H104KC	CAP , CHIP	0.1UF 50V K	1	EA
C928	HCEC1CRV2220T	CAP , CHIP ELECT	22UF/16V	1	EA
C929	CCUS1H104KC	CAP , CHIP	0.1UF 50V K	1	EA
C930	HCEC1CRV2220T	CAP , CHIP ELECT	22UF/16V	1	EA
<i>Semiconductors</i>					
IC91	CVISII9185ACTU	I.C , HDMI RX SW(80PIN TQFP)	SILICON IMAGE(SII9185ACTU)	1	EA
IC92	CVIKIA1117S50	I.C , REGULATOR(SOT-223)	KEC(KIA1117S50-RTK/P)	1	EA
IC93	CVIKIA1117S33	I.C , REGULATOR(SOT-223)	KEC(KIA1117S/F33, SOT-223)	1	EA
IC94	CVIKIA1117S18	I.C , REGULATOR(SOT-223)	KEC(KIA1117S/F18, SOT-223)	1	EA
Q901	HVTKRA102S	TRANSISTOR , PNP, CHIP	KRA102S	1	EA
Q902	CVTKRC103S	TRANSISTOR , PNP, CHIP	KRC103S	1	EA
Q903	HVTKRA102S	TRANSISTOR , PNP, CHIP	KRA102S	1	EA
Q904	CVTKRC103S	TRANSISTOR , PNP, CHIP	KRC103S	1	EA
Q905	HVTKRA102S	TRANSISTOR , PNP, CHIP	KRA102S	1	EA
Q906	CVTKRC103S	TRANSISTOR , PNP, CHIP	KRC103S	1	EA
<i>Resistors</i>					
R901	CRJ10DJ102T	RES , CHIP	1K OHM	1	EA
R902	CRJ10DJ223T	RES , CHIP	22K OHM	1	EA
R911	CRJ10DJ102T	RES , CHIP	1K OHM	1	EA
R912	CRJ10DJ223T	RES , CHIP	22K OHM	1	EA
R915	CRJ10DJ103T	RES , CHIP	10K OHM	1	EA
R916	CRJ10DJ103T	RES , CHIP	10K OHM	1	EA
R921	CRJ10DJ102T	RES , CHIP	1K OHM	1	EA
R922	CRJ10DJ223T	RES , CHIP	22K OHM	1	EA
R932	CRJ10DJ473T	RES , CHIP	47K OHM	1	EA
R933	CRJ10DJ152T	RES , CHIP	1.5K OHM	1	EA
R934	CRJ10DJ152T	RES , CHIP	1.5K OHM	1	EA
R935	CRJ10DJ473T	RES , CHIP	47K OHM	1	EA
R936	CRJ10DJ473T	RES , CHIP	47K OHM	1	EA
R937	CRJ10DJ202T	RES , CHIP	2K OHM	1	EA
R938	CRJ10DJ202T	RES , CHIP	2K OHM	1	EA
R939	CRJ10DJ221T	RES , CHIP	220 OHM	1	EA
R940	CRJ10DJ221T	RES , CHIP	220 OHM	1	EA

Ref. Designator	Part Number	Description		Qty	
HDMI PCB		(CUP12109)			
R941	CRJ10DJ221T	RES , CHIP	220 OHM	1	EA
R963	CRJ10DJ473T	RES , CHIP	47K OHM	1	EA
R964	CRJ10DJ101T	RES , CHIP	100 OHM	1	EA
<i>Miscellaneous</i>					
CN45	CJP07GA193ZY	WAFER , CARD CABLE SMD	WAFER	1	EA
JK81	HJJ9H003Z	JACK , HDMI(JALCO)	YKF45-7009	1	EA
JK82	HJJ9H003Z	JACK , HDMI(JALCO)	YKF45-7009	1	EA
JK83	HJJ9H003Z	JACK , HDMI(JALCO)	YKF45-7009	1	EA
JK84	HJJ9H003Z	JACK , HDMI(JALCO)	YKF45-7009	1	EA
L823	CLZ9R009Z	CHOKO COIL, CHIP (FOR HDMI)	CMM21T-900M-3H	1	EA
L824	CLZ9R009Z	CHOKO COIL, CHIP (FOR HDMI)	CMM21T-900M-3H	1	EA
L825	CLZ9R009Z	CHOKO COIL, CHIP (FOR HDMI)	CMM21T-900M-3H	1	EA
L826	CLZ9R009Z	CHOKO COIL, CHIP (FOR HDMI)	CMM21T-900M-3H	1	EA
L901	CLZ9Z014Z	FERRITE , CHIP BEAD(60ohm, 4516)	HCB4516KF-600T60	1	EA
L902	CLZ9R005Z	FERRITE , CHIP BEAD(60ohm, 1608)	HCB1608KF-600T30	1	EA
L903	CLZ9Z014Z	FERRITE , CHIP BEAD(60ohm, 4516)	HCB4516KF-600T60	1	EA
AVR 154 TUNER MODULE		CNVM9001MS0J73L			



AK4589

2/8-Channel Audio CODEC with DIR

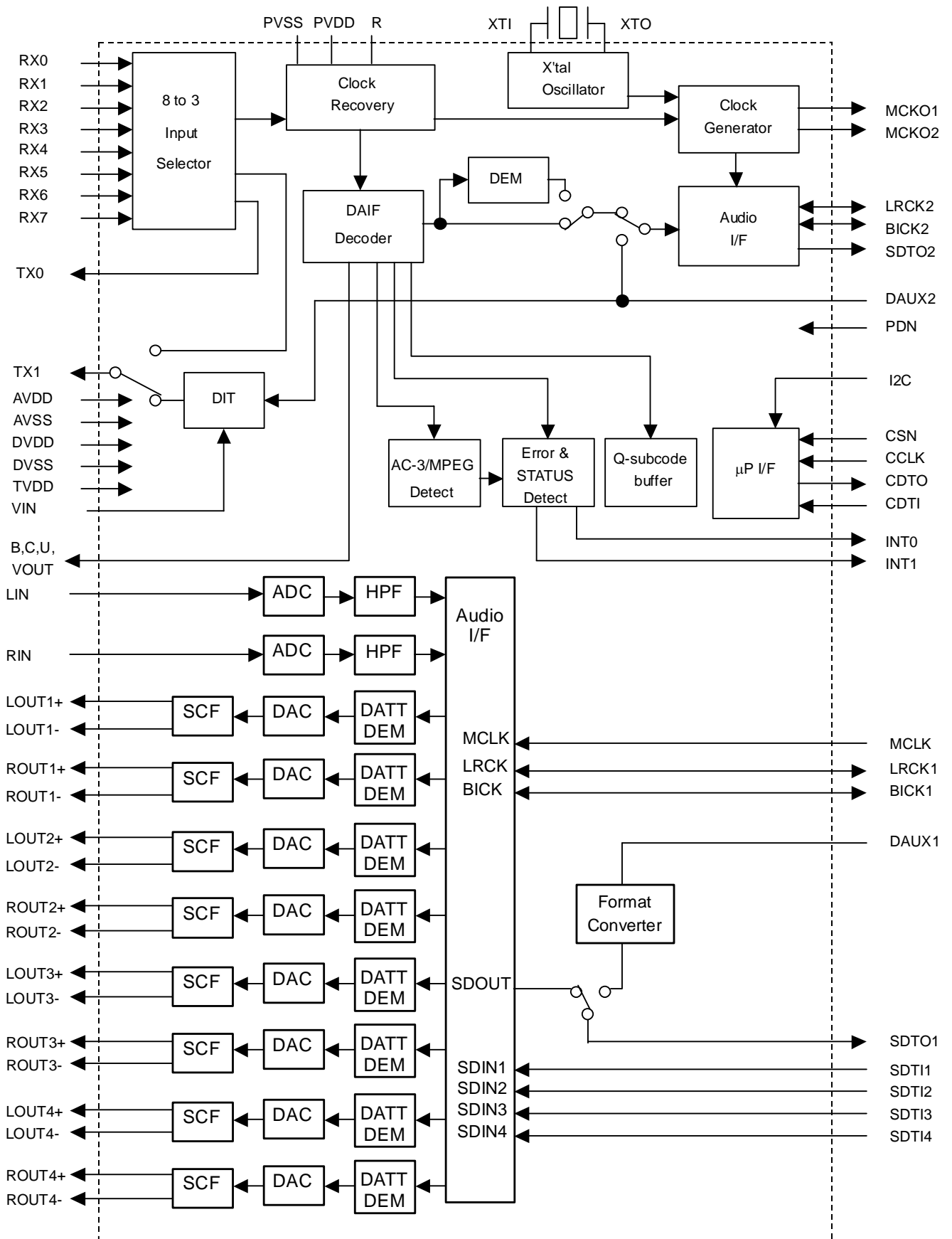

■ オーダリングガイド

AK4589VQ
AKD4589

-10 ~ +70°C
評価ボード

80pin LQFP(0.5mm pitch)

■ ピン配置

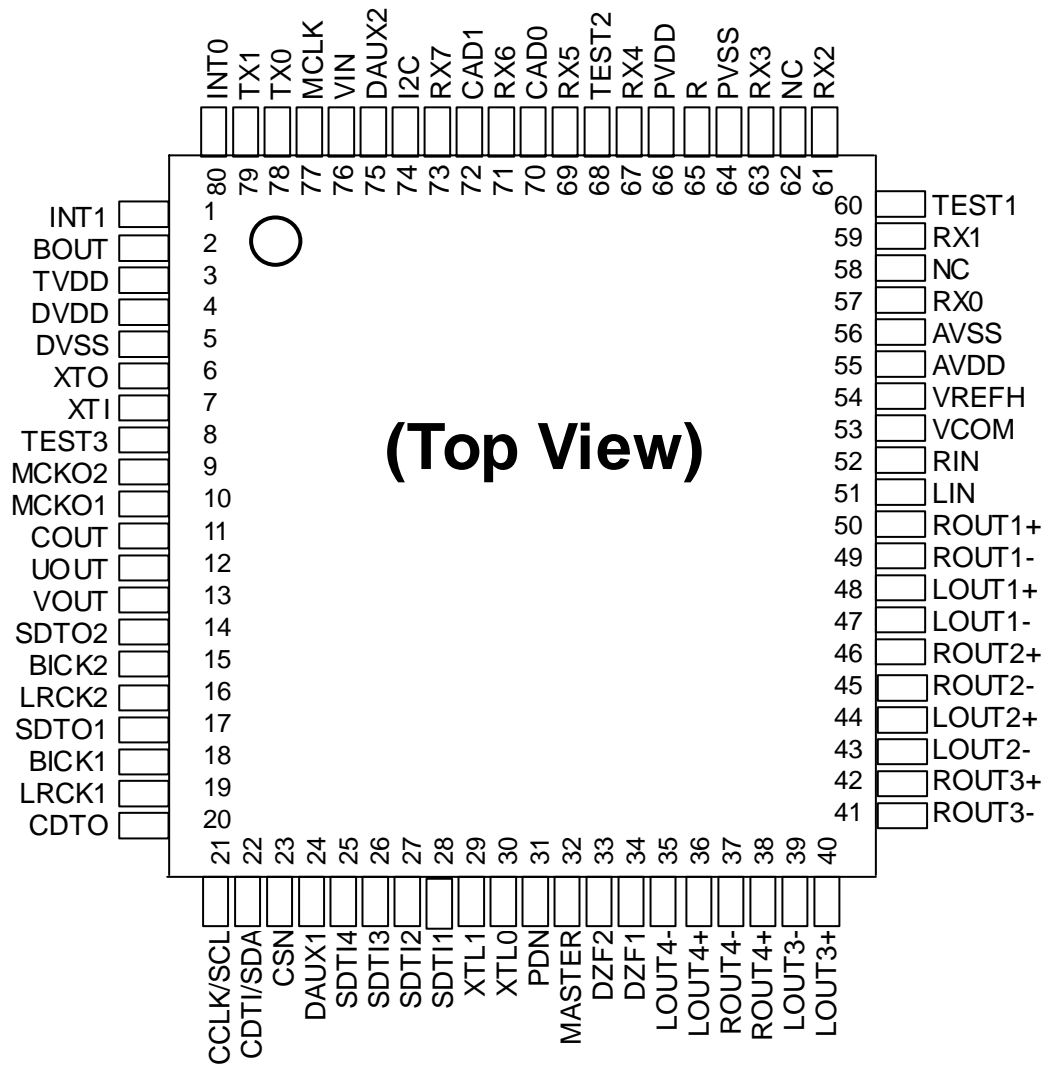

■ AK4588 との相違点

Functions	AK4588	AK4589
DAC 出力	シングルエンド	差動
DAC S/(N+D)	90dB	94dB
DAC S/N	106dB	114dB
DAC Output voltage	Typ 3.0Vpp	Typ ± 2.7 Vpp
DAC AOUT	AOUT=0.6xVREFH	AOUT=0.54xVREFH
Load Resistance	5k ohm	2k ohm
Frequency Response 80kHz	± 1.0	+0/-0.6
アナログ出力ピン	#35, #37, #39, #41, #43, #45, #47, #49	#35 - #50
電源電圧	Min=4.5V, Max=5.5V	Min=4.75V, Max=5.25V

(注)AK4589 は内部に ADC/DAC 部レジスタ(AK4588 レジスタ互換)と DIR/DIT 部レジスタ(AK4588 レジスタ互換)の 2 つのレジスタをもちます。それぞれのレジスタはチップアドレスで指定します。

ピン / 機能

No.	Pin Name	I/O	Function
1	INT1	O	Interrupt 1 Pin
2	BOUT	O	Block-Start Output Pin for Receiver Input “H” during first 40 frames.
3	TVDD	-	Output Buffer Power Supply Pin, 2.7V~5.25V
4	DVDD	-	Digital Power Supply Pin, 4.75V~5.25V
5	DVSS	-	Digital Ground Pin
6	XTO	O	X'tal Output Pin
7	XTI	I	X'tal Input Pin
8	TEST3	I	Test 3 Pin This pin should be connected to DVSS.
9	MCKO2	O	Master Clock Output 2 Pin
10	MCKO1	O	Master Clock Output 1 Pin
11	COUT	O	C-bit Output Pin for Receiver Input
12	UOUT	O	U-bit Output Pin for Receiver Input
13	VOUT	O	V-bit Output Pin for Receiver Input
14	SDTO2	O	Audio Serial Data Output Pin (DIR/DIT part)
15	BICK2	I/O	Audio Serial Data Clock Pin (DIR/DIT part)
16	LRCK2	I/O	Channel Clock Pin (DIR/DIT part)
17	SDTO1	O	Audio Serial Data Output Pin (ADC/DAC part)
18	BICK1	I/O	Audio Serial Data Clock Pin (ADC/DAC part)
19	LRCK1	I/O	Input Channel Clock Pin
20	CDTO	O	Control Data Output Pin in Serial Mode, I2C= “L”.
21	CCLK	I	Control Data Clock Pin in Serial Mode, I2C= “L”
	SCL	I	Control Data Clock Pin in Serial Mode, I2C= “H”
22	CDTI	I	Control Data Input Pin in Serial Mode, I2C= “L”.
	SDA	I/O	Control Data Pin in Serial Mode, I2C= “H”.
23	CSN	I	Chip Select Pin in Serial Mode, I2C= “L”.
		I	This pin should be connected to DVSS, I2C= “H”.
24	DAUX1	I	AUX Audio Serial Data Input Pin (ADC/DAC part)
25	SDTI4	I	DAC4 Audio Serial Data Input Pin
26	SDTI3	I	DAC3 Audio Serial Data Input Pin
27	SDTI2	I	DAC2 Audio Serial Data Input Pin
28	SDTI1	I	DAC1 Audio Serial Data Input Pin
29	XTL1	I	X'tal Frequency Select 0 Pin
30	XTL0	I	X'tal Frequency Select 1 Pin

No.	Pin Name	I/O	Function
31	PDN	I	Power-Down Mode Pin When “L”, the AK4589 is powered-down, all digital output pins go “L”, all registers are reset. When CAD1/0 pins are changed, the AK4589 should be reset by PDN pin.
32	MASTER	I	Master Mode Select Pin “H”: Master mode, “L”: Slave mode
33	DZF2	O	Zero Input Detect 2 Pin (Table 13) When the input data of the group 1 follow total 8192 LRCK cycles with “0” input data, this pin goes to “H”. And when RSTN bit is “0”, PWDAN bit is “0”, this pin goes to “H”. It always is in “L” when P/S pin is “H”.
	OVF	O	Analog Input Overflow Detect Pin This pin goes to “H” if the analog input of Lch or Rch overflows.
34	DZF1	O	Zero Input Detect 1 Pin (Table 13) When the input data of the group 1 follow total 8192 LRCK cycles with “0” input data, this pin goes to “H”. And when RSTN bit is “0”, PWDAN bit is “0”, this pin goes to “H”. Output is selected by setting DZFE pin when P/S pin is “H”.
35	LOUT4-	O	DAC4 Lch Negative Analog Output Pin
36	LOUT4+	O	DAC4 Lch Positive Analog Output Pin
37	ROUT4-	O	DAC4 Rch Negative Analog Output Pin
38	ROUT4+	O	DAC4 Rch Positive Analog Output Pin
39	LOUT3-	O	DAC3 Lch Negative Analog Output Pin
40	LOUT3+	O	DAC3 Lch Positive Analog Output Pin
41	ROUT3-	O	DAC3 Rch Negative Analog Output Pin
42	ROUT3+	O	DAC3 Rch Positive Analog Output Pin
43	LOUT2-	O	DAC2 Lch Negative Analog Output Pin
44	LOUT2+	O	DAC2 Lch Positive Analog Output Pin
45	ROUT2-	O	DAC2 Rch Negative Analog Output Pin
46	ROUT2+	O	DAC2 Rch Positive Analog Output Pin
47	LOUT1-	O	DAC1 Lch Negative Analog Output Pin
48	LOUT1+	O	DAC1 Lch Positive Analog Output Pin
49	ROUT1-	O	DAC1 Rch Negative Analog Output Pin
50	ROUT1+	O	DAC1 Rch Positive Analog Output Pin
51	LIN	I	Lch Analog Input Pin
52	RIN	I	Rch Analog Input Pin
53	VCOM	-	Common Voltage Output Pin 2.2 μ F capacitor should be connected to AVSS externally.
54	VREFH	-	Positive Voltage Reference Input Pin, AVDD

No.	Pin Name	I/O	Function
55	AVDD	-	Analog Power Supply Pin, 4.75V~5.25V
56	AVSS	-	Analog Ground Pin, 0V
57	RX0	I	Receiver Channel 0 Pin (Internal biased pin. Internally biased at PVDD/2)
58	NC	-	No Connect pin No internal bonding. This pin should be connected to PVSS.
59	RX1	I	Receiver Channel 1 Pin (Internal biased pin. Internally biased at PVDD/2)
60	TEST1	I	Test 1 Pin This pin should be connected to PVSS.
61	RX2	I	Receiver Channel 2 Pin (Internal biased pin. Internally biased at PVDD/2)
62	NC	-	No Connect pin No internal bonding. This pin should be connected to PVSS.
63	RX3	I	Receiver Channel 3 Pin (Internal biased pin. Internally biased at PVDD/2)
64	PVSS	-	PLL Ground pin
65	R	-	External Resistor Pin 12kΩ +/-1% resistor should be connected to PVSS externally.
66	PVDD	-	PLL Power supply Pin, 4.75V~5.25V
67	RX4	I	Receiver Channel 4 Pin (Internal biased pin. Internally biased at PVDD/2)
68	TEST2	I	Test 2 Pin This pin should be connected to PVSS.
69	RX5	I	Receiver Channel 5 Pin (Internal biased pin. Internally biased at PVDD/2)
70	CAD0	I	Chip Address 0 Pin (ADC/DAC part)
71	RX6	I	Receiver Channel 6 Pin (Internal biased pin. Internally biased at PVDD/2)
72	CAD1	I	Chip Address 1 Pin (ADC/DAC part)
73	RX7	I	Receiver Channel 7 Pin (Internal biased pin. Internally biased at PVDD/2)
74	I2C	I	Control Mode Select Pin. “L”: 4-wire Serial, “H”: I ² C Bus
75	DAUX2	I	Auxiliary Audio Data Input Pin (DIR/DIT part)
76	VIN	I	V-bit Input Pin for Transmitter Output
77	MCLK	I	Master Clock Input Pin
78	TX0	O	Transmit Channel (Through Data) Output 0 Pin
79	TX1	O	Transmit Channel Output 1 pin When DIT bit = “0”, Through Data. When DIT bit = “1”, DAUX2 Data.
80	INT0	O	Interrupt 0 Pin

Notes: 内部バイアスピピンとアナログ入力ピン(RX0-7, LIN, RIN)を除くすべての入力ピンはフローティングにしないで下さい。

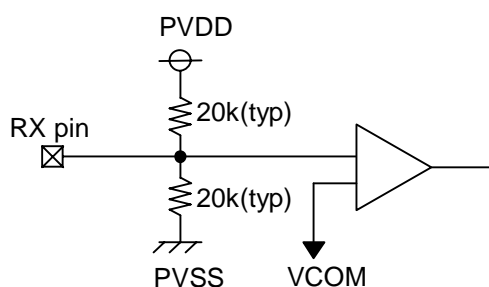

Internal biased pin Circuit

■ 使用しないピンの処理について

使用しない入出力ピンは下記の設定を行い、適切に処理して下さい。

Classification	Pin Name	Setting
Analog	RX0-7, LOUT1-4, ROUT1-4, LIN, RIN	These pins should be open.
Digital	INT0-1, BOUT, XTO, MCKO1-2, COUT, UOUT, VOUT, SDTO1-2, CDTO, DZF1-2, TX1-0	These pins should be open.
	CSN, DAUX1-2, SDTI1-4, XTL0-1	These pins should be connected to DVSS.
	TEST1-3	These pins should be connected to PVSS.

MITSUMI

Video Switch · 75Ω driver · Y/C mix MM1501

Video Switch · 75Ω driver · Y/C mix Monolithic IC MM1501 Series

Outline

This IC extends the series of ICs for video/audio signal switching, with a 2-input 1-output single video switch, video signal/chroma signal 75Ω driver, and Y/C mixing circuit in one small package (SOT-26).

Features

- (1) Low power consumption achieved.
- (2) Low power supply voltage realized.
- (3) Frequency bandwidth without 75Ω driver: 10MHz with 75Ω driver: 7MHz
- (4) Cross talk 70dB When 4.43MHz
- (5) With SAG measures pin (75Ω driver and Y/C mix driver)

Package

- SOT-26A (with 75Ω driver)
- SOT-26B (without 75Ω driver)

Applications

- (1) TV
- (2) VTR
- (3) Video camera
- (4) Digital still camera
- (5) Other visual equipment

Line-up

Functions	Model Name	Input	Output	Clamp	6dB amp	75Ω driver	SAG measures pin	Power supply voltage
Switch	MM1501	2	1	×	×	×	×	4.5~13.0V
	MM1502			×	○	×	×	4.5~13.0V
	MM1503			○	×	×	×	4.5~13.0V
	MM1504			○	○	×	×	4.5~13.0V
	MM1505			×	×	○	×	4.5~13.0V
	MM1506			×	○	○	×	4.5~13.0V
	MM1507			○	×	○	×	4.5~13.0V
	MM1508			○	○	○	×	4.5~13.0V
Driver	MM1509	1	1	×	○	○	○	4.5~13.0V
	MM1510			○	○	○	○	4.5~13.0V
Y/C mix	MM1511	1	1	○/×	×	×	×	4.5~13.0V
	MM1512			○/×	○	○	○	4.5~13.0V

MITSUMI

Video Switch · 75Ω driver · Y/C mix MM1501

Block Diagram

■ MM1501

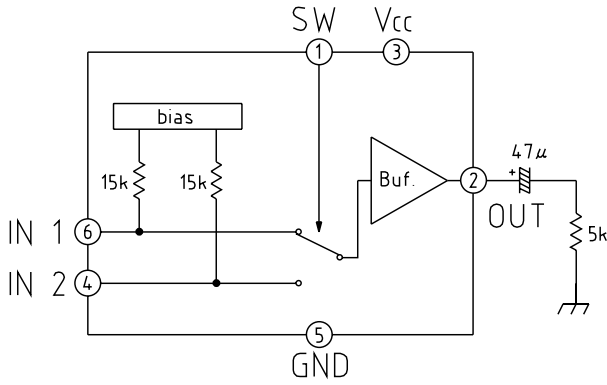

■ MM1502

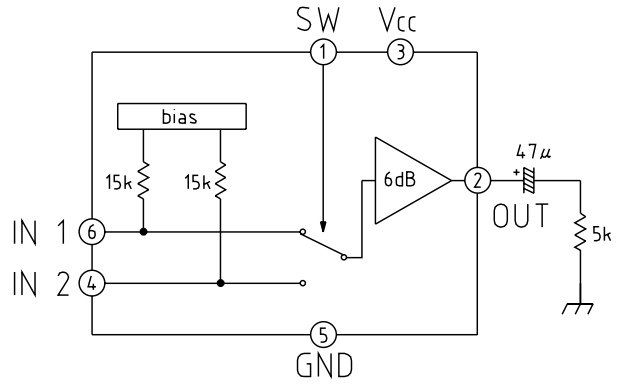

■ MM1503

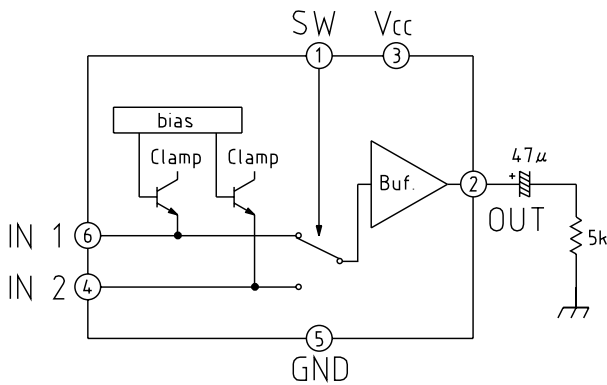

■ MM1504

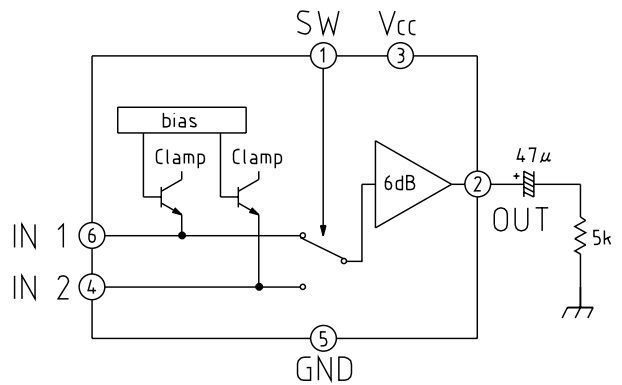

■ MM1505

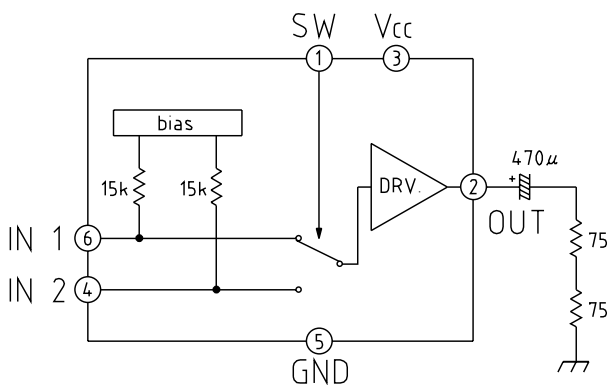

■ MM1506

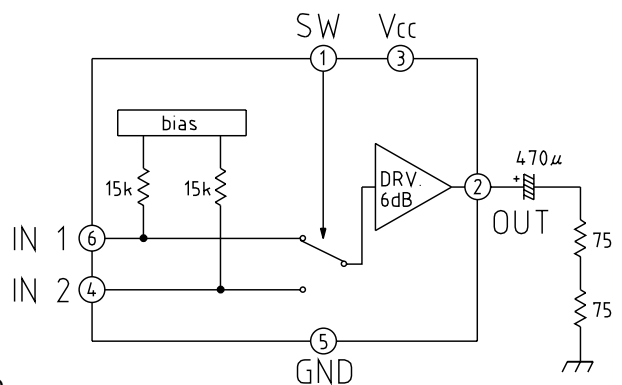

MITSUMI

Video Switch · 75Ω driver · Y/C mix MM1501

MM1507

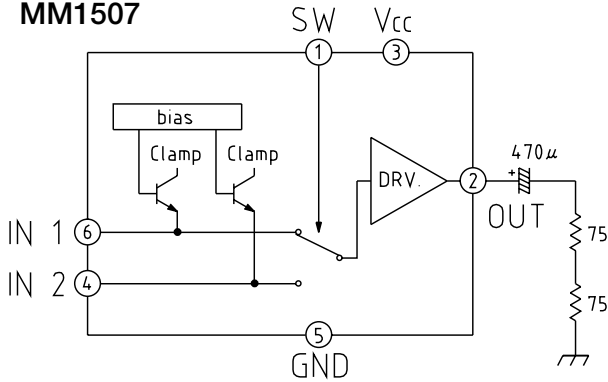

MM1508

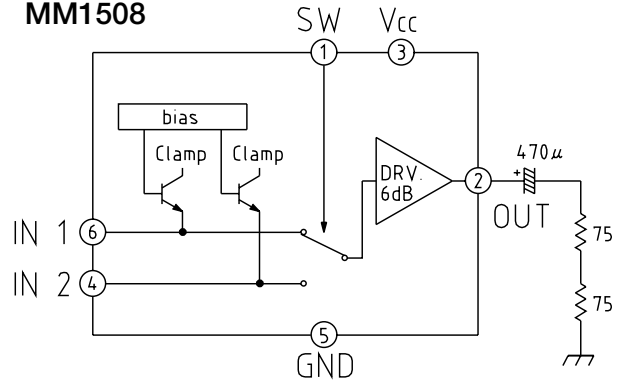

MM1509

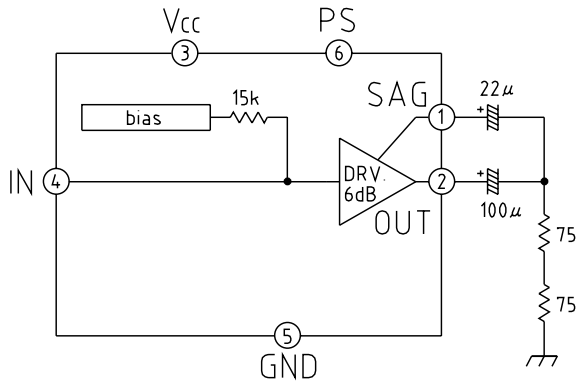

MM1510

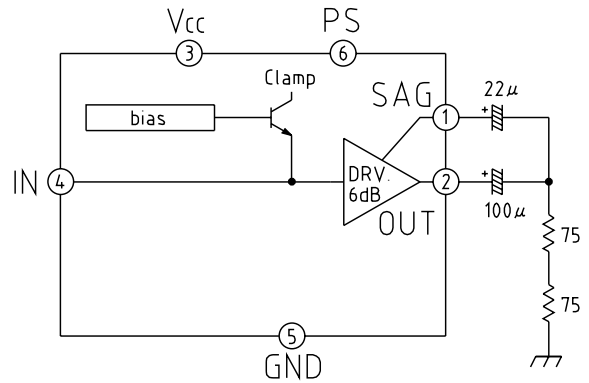

MM1511

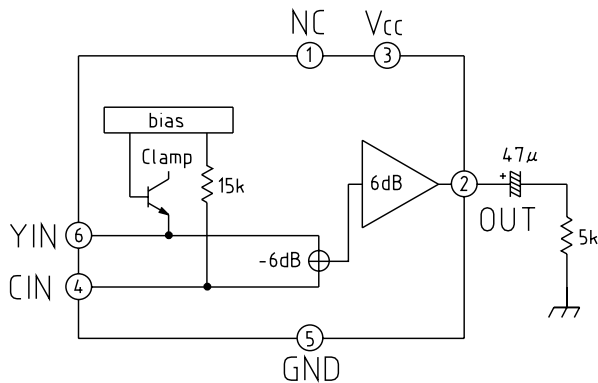

MM1512

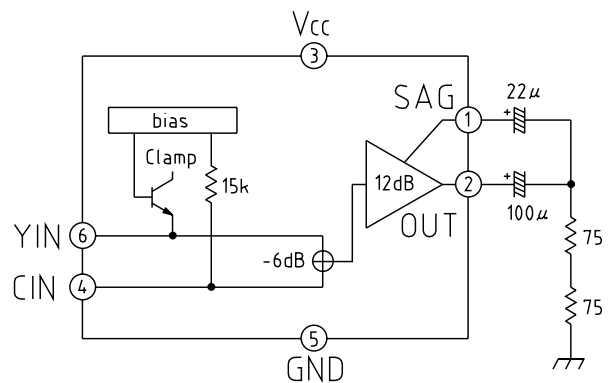



HCF4053B

TRIPLE 2-CHANNEL ANALOG MULTIPLEXER/DEMULTIPLEXER

- LOW "ON" RESISTANCE : 125 Ω (Typ.) OVER 15V p.p SIGNAL-INPUT RANGE FOR $V_{DD} - V_{EE} = 15V$
- HIGH "OFF" RESISTANCE : CHANNEL LEAKAGE $\pm 100pA$ (Typ.) at $V_{DD} - V_{EE} = 18V$
- BINARY ADDRESS DECODING ON CHIP
- HIGH DEGREE OF LINEARITY : < 0.5% DISTORTION TYP. at $f_{IS} = 1KHz$, $V_{IS} = 5 V_{pp}$, $V_{DD} - V_{SS} \geq 10V$, $R_L = 10K\Omega$
- VERY LOW QUIESCENT POWER DISSIPATION UNDER ALL DIGITAL CONTROL INPUT AND SUPPLY CONDITIONS : 0.2 μW (Typ.) at $V_{DD} - V_{SS} = V_{DD} - V_{EE} = 10V$
- MATCHED SWITCH CHARACTERISTICS : $R_{ON} = 5\Omega$ (Typ.) FOR $V_{DD} - V_{EE} = 15V$
- WIDE RANGE OF DIGITAL AND ANALOG SIGNAL LEVELS : DIGITAL 3 to 20, ANALOG TO 20V p.p.
- QUIESCENT CURRENT SPECIF. UP TO 20V
- 5V, 10V AND 15V PARAMETRIC RATINGS
- INPUT LEAKAGE CURRENT $I_l = 100nA$ (MAX) AT $V_{DD} = 18V$ $T_A = 25^\circ C$
- 100% TESTED FOR QUIESCENT CURRENT
- MEETS ALL REQUIREMENTS OF JEDEC JESD13B " STANDARD SPECIFICATIONS FOR DESCRIPTION OF B SERIES CMOS DEVICES"

DESCRIPTION

The HCF4053B is a monolithic integrated circuit fabricated in Metal Oxide Semiconductor

PIN CONNECTION

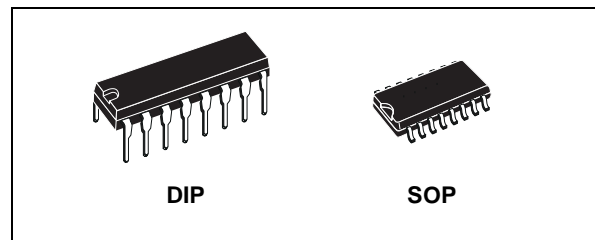
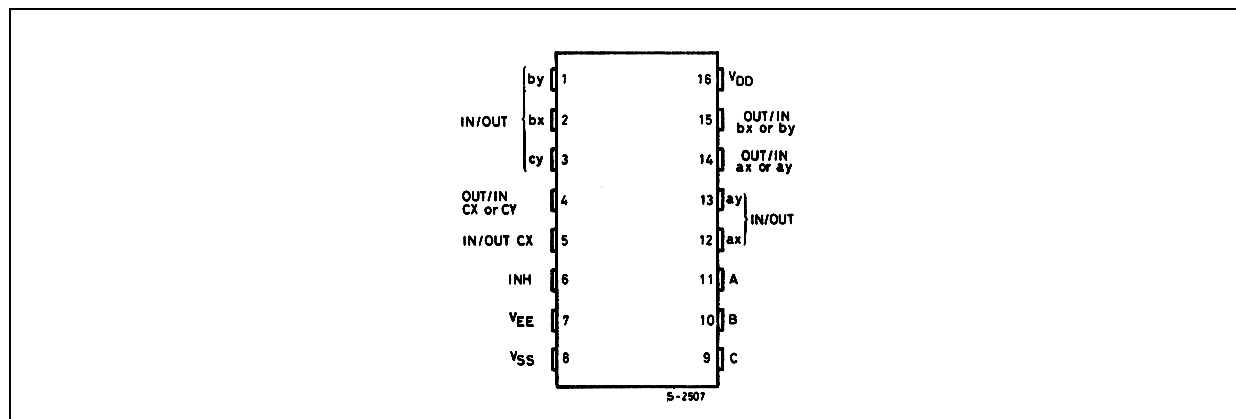

ORDER CODES

PACKAGE	TUBE	T & R
DIP	HCF4053BEY	
SOP	HCF4053BM1	HCF4053M013TR

technology available in DIP and SOP packages.

The HCF4053B analog multiplexer/demultiplexer is a digitally controlled analog switch having low ON impedance and very low OFF leakage current. This multiplexer circuit dissipate extremely low quiescent power over the full $V_{DD} - V_{SS}$ and $V_{DD} - V_{EE}$ supply voltage range, independent of the logic state of the control signals.

When a logic "1" is present at the inhibit input terminal all channel are off. This device is a triple 2-channel multiplexer having three separate digital control inputs, A, B, and C, and an inhibit input. Each control input selects one of a pair of channels which are connected in a single pole double-throw configuration.

HCF4053B

INPUT EQUIVALENT CIRCUIT

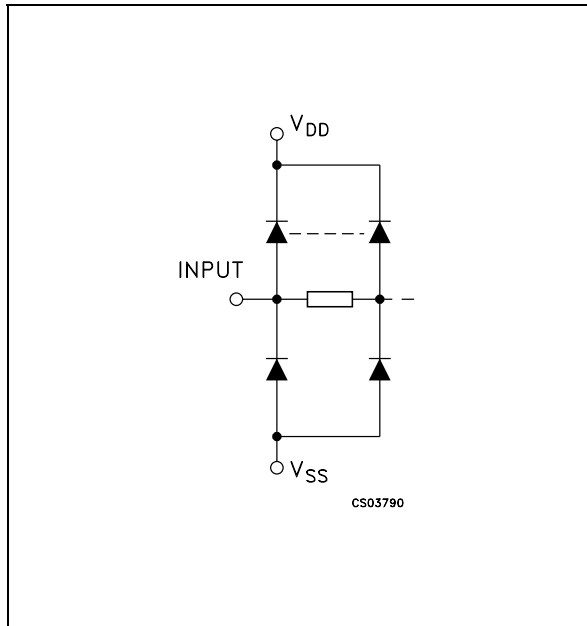

PIN DESCRIPTION

PIN No	SYMBOL	NAME AND FUNCTION
11, 10, 9	A, B, C	Binary Control Inputs
6	INH	Inhibit Inputs
12, 13, 2, 1, 5, 3	IN/OUT	$a_x, a_y, b_x, b_y, c_x, c_y$ Input/Output
14	OUT/IN	a_x or a_y
15	OUT/IN	b_x or b_y
4	OUT/IN	c_x or c_y
7	V_{EE}	Supply Voltage
8	V_{SS}	Negative Supply Voltage
16	V_{DD}	Positive Supply Voltage

TRUTH TABLE

INHIBIT	C or B or A	
0	0	a_x or b_x or c_x
0	1	a_y or b_y or c_y
1	X	NONE

X : Don't Care

FUNCTIONAL DIAGRAM

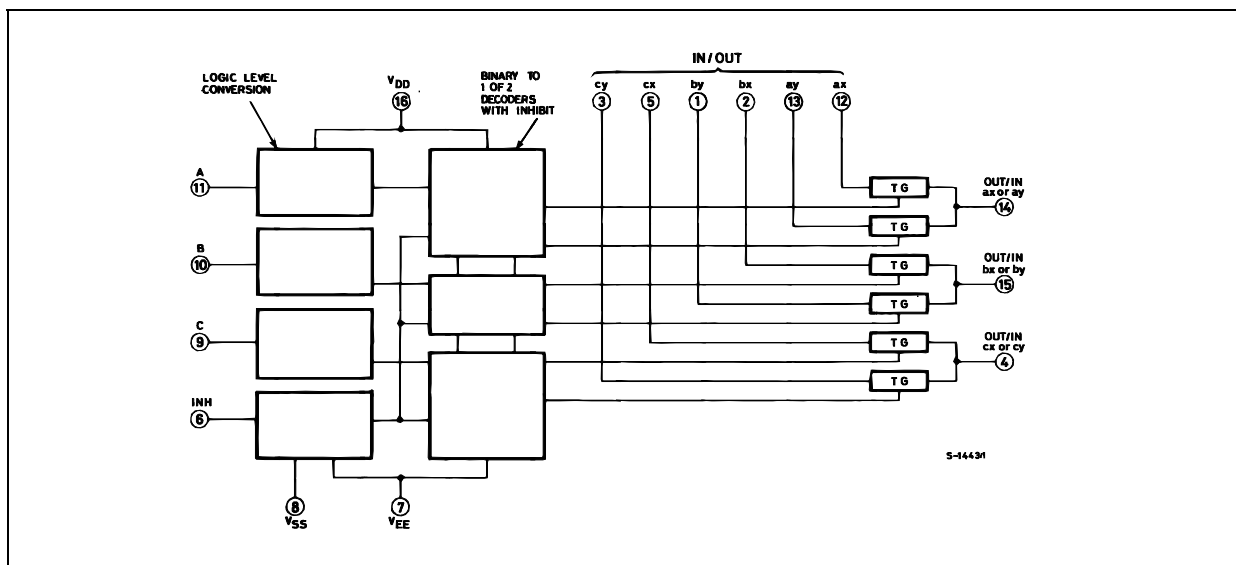



CS495xx Data Sheet

FEATURES

- Powerful 32-bit Dual-core Audio DSP
- Multi-standard 32-bit Audio Decoding plus Post Processing, Dual-decode Capable
- Framework Applications Library
 - Dolby® Digital Pro Logic® IIx, Dolby® Digital EX, Dolby® Digital Headphone™, Dolby® Digital Virtual Speaker™
 - DTS-ES 96/24™, DTS-ES™ Discrete 6.1, DTS-ES™ Matrix 6.1, DTS® Digital Surround
 - MPEG-2 Multichannel
 - AAC™ Multichannel 5.1
 - MP3 - MPEG-1/2, Layer III
 - THX® Surround EX™, THX® Ultra2 Cinema™
 - DVD Audio/Video/SACD Multichannel Bass Management
- 10 Channels of 32-bit Serial Audio Input
- 16 Channels of 32-bit PCM Output
- Two Master/slave SPI or I²C Format Control Ports for Audio Subsystem Management
- Parallel Host Control & UART
- Customer Software Security Keys
- Large On-chip X, Y, and Program RAM & ROM
- SDRAM, SRAM, and FLASH Memory Support
- Dual 192-kHz SPDIF Transmitters

32-bit Audio Decoder DSP Family

The CS495xx DSP family integrates two programmable, 32-bit DSP cores and a DMA engine with a full set of audio peripherals. Feature-rich AVR designs can be easily developed using the Framework applications library, which includes both certified application programs and a modular programming environment for easy customization. The framework includes certified state-of-the-art audio decoders, virtualizers, surround simulators, and audio enhancement algorithms.

The CS495xx family was designed to reduce system costs and development time and to provide advanced features and flexibility for competitive system-level solutions. The difficult processing tasks of Dolby® Digital Surround EX™, AAC multichannel, DTS-ES 96/24, and THX Ultra2 Cinema can be accomplished without the expense of external logic or memory. Additionally, the CS495xx can meet the needs of dual-decode applications with twin DSP cores, and audio-I/O-intensive designs with support for up to 10 input and 16 output channels.

Ordering Information

See page 33 for ordering information

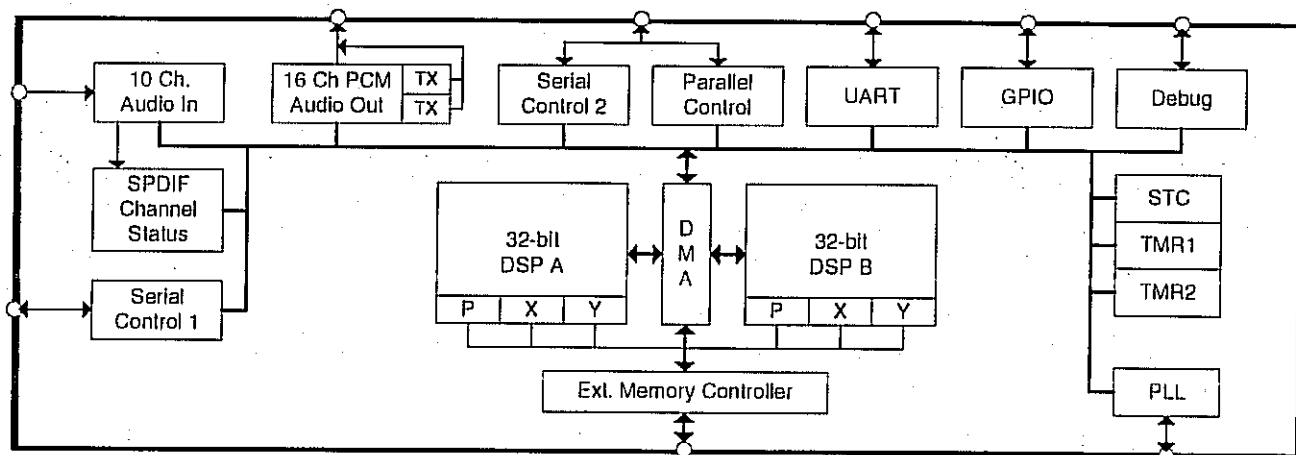

Preliminary Product Information

This document contains information for a new product. Cirrus Logic reserves the right to modify this product without notice.



©Copyright 2005 Cirrus Logic, Inc.

NOV '05
DS631PP4

CS495xx Data Sheet
32-bit Audio Decoder DSP Family



Device	Firmware	Decoder	Mid-Processor	Post-Processor
CS495002 -CQZ 90 MHz 1080 MOPS -DQZ 80 MHz 960 MOPS	Firmware Pack	Dolby Digital DTS-ES DTS96/24 MPEG SGEN PCM (2Fs) AAC	PLIIx DTS Neo:6 Downmix Cirrus Original Surround	Tone Control Parametric EQ Bass Manager Delay
	Unbundled Code		Circle Surround (1Fs) Tru-Surround XT (1Fs)	Auto Speaker Setup (IRC1)
CS495102 <i>(Superset of CS495002)</i> -CQZ 110 MHz 1320 MOPS -DQZ 90 MHz 1080 MOPS	Firmware Pack	Dolby Digital DTS-ES DTS-ES96/24 MPEG SGEN PCM (2Fs) AAC	PLIIx DTS Neo:6 Downmix Cirrus Original Multichannel Surround	Tone Control Parametric EQ Bass Manager Delay
	Unbundled Code		Tru-Surround XT Circle Surround	Automatic Room EQ (IRC2) Dolby Headphone Dolby Headphone 2 Dolby Virtual Speaker Dolby Virtual Speaker 2
CS495202 <i>(Superset of CS495102)</i> -CQZ 120 MHz 1440 MOPS -DQZ 100 MHz 1200 MOPS	Firmware Pack	Dolby Digital DTS-ES DTS-ES96/24 MPEG SGEN PCM AAC	PLIIx DTS Neo:6 Downmix Cirrus Original Multichannel Surround	Tone Control 11-Band PEQ Bass Manager Delay THX Select THX Select2 THX Ultra2
	Unbundled Code		Tru-Surround XT Circle Surround	Automatic Room EQ (IRC2) Dolby Headphone Dolby Headphone 2 Dolby Virtual Speaker Dolby Virtual Speaker 2

Table 1. Device and Firmware Selection Guide



4. Hardware Functional Description

4.1 DSP Core

The CS495xx is a dual-core DSP with separate X- and Y-data memory spaces, and a separate P-code memory space. Each core is a high-performance, 32-bit, user-programmable, fixed-point DSP that is capable of performing two memory access control (MAC) operations per clock cycle. Each core has eight 72-bit accumulators, four X- and four Y-data registers, and 12 index registers.

Both DSP cores are coupled to a flexible DMA engine. The DMA engine can move data between peripherals such as the DAI and DAO, external memory, or any DSP core memory, all without the intervention of the DSP. The DMA engine offloads data move instructions from the DSP core, leaving more MIPS available for signal processing instructions.

The DSP obtains its functionality from application codes that are downloaded to the CS495xx and are provided through the Cirrus Logic Crystal Ware™ Software Licensing Program.

Both DSP cores are user-programmable in order to offer the customer the ability to implement unique post-processing algorithms. Additionally, users can choose to download standard audio decoder and post-processing modules which are available through the Cirrus Logic Crystal Ware™ Software Licensing Program.

The CS495xx is suitable for AVR/Outboard Decoder, DVD Audio/Video Player, and Digital Broadcast applications.

4.1.1 DSP Memory

Each DSP core has its own on-chip data and program memory and does not require external memory for any of today's popular audio algorithms including Dolby Digital Surround EX, AAC Multichannel, DTS-ES 96/24, and THX Ultra2 Cinema.

The memory maps for the DSPs are as follows. All memory sizes are composed of 32-bit words.

Memory Type	DSP A	DSP B
X	16k SRAM, 32k ROM	8k SRAM, 8k ROM
Y	16k SRAM, 32k ROM	16k SRAM, 8k ROM
P	8k SRAM, 32k ROM	8k SRAM, 8k ROM

Table 2. DSP Memory Sizes

4.1.2 DMA Controller

The powerful 12-channel DMA controller can move data between 8 on-chip resources. Each resource has its own arbiter: X-, Y-, and P-RAMs on DSP A; X-, Y-, P-RAMs on DSP B; external memory; and the peripheral bus. Modulo and linear addressing modes are supported, with flexible start address and increment controls. The service interval for each DMA channel as well as up to 6 interrupt events, is programmable.

4.2 On-chip DSP Peripherals

4.2.1 Digital Audio Input Port (DAI)

The 10-channel DAI port supports a wide variety of data input formats. The port is capable of accepting PCM or IEC61937. Up to 32-bit PCM and 16-bit compressed data input word lengths are supported. The port has two independent slave-only clock domains, each data input can be independently assigned to a clock domain. The sample rate of the input clock domains can be determined automatically by the DSP, eliminating the host from the task of monitoring the SPDIF receiver. A special channel status word function separates IEC channel status data from PCM data and places it into a separate data buffer for analysis by the DSP. A time-stamping feature allows the input data to be sample-rate converted via software.

4.2.2 Digital Audio Output Port (DAO)

There are two DAO ports, each port can output 8 channels of up to 32-bit PCM data. The port supports data rates from 32kHz to 192kHz. Each port can be configured as an independent clock domain in slave mode, or the ratio of the two clocks can be set to even multiples of each other in master mode. The two ports can be ganged together into a single clock domain. Each port has a 192kHz SPDIF transmitter that can be used instead of a PCM output.

4.2.3 Serial Control Port 1 & 2 (I²C or SPI)

There are two on-chip serial control ports that are capable of operating in master or slave mode in either I²C or SPI modes. Serial control port 2 shares pins with the parallel control port.

4.2.4 Parallel Control Port

The CS495xx parallel port can be used for either parallel control (Motorola[®], Intel[®], or multiplexed Intel modes). The parallel port pins are muxed with serial control port 2.

4.2.5 External Memory Interface

The external memory interface controller supports up to 128 Mbit of SDRAM, using a 16-bit data bus. The memory controller supports up to 1MB of SRAM and 1MB of FLASH memory in either 8-bit or 16-bit bus widths.

4.2.6 GPIO

The CS495xx has 42 GPIO pins multiplexed with other peripheral functions. Each GPIO can be configured as an output, an input, or an input with interrupt. Each input-pin interrupt can be configured as rising edge, falling edge, active-low, or active-high.

4.2.7 Channel Status Word (CSW)

The Channel Status Word peripheral extracts SPDIF IEC data and stores it in the CS495xx's internal memory for use by application code. The CSW operates in two modes: 1. extracting data from a DAI channel that is connected to a SPDIF receiver such as the Cirrus Logic CS8416 configured in IEC format mode (IEC data embedded in the I²S stream); or 2. capturing IEC data output from a SPDIF receiver on discrete data, clock, and frame clock pins. The CSW has two data input pins to capture two simultaneous synchronous data streams (U and C).

4.2.8 PLL-based Clock Generator

The PLL-based clock generator provides clock generation and system synchronization for the device. The low-jitter PLL generates integer multiples of a reference frequency which are used to clock the DSP core and peripherals. A second, dependent clock domain can be output on the DAO port for driving Delta-Sigma audio converters. The CS495xx is clocked from the external reference frequency until the



PLL is configured and locked, at which time the clocks can be switched. A built-in crystal oscillator circuit with dedicated, buffered output pin is provided to eliminate an external crystal oscillator.

4.3 DSP I/O Description

4.3.1 Multiplexed Pins

The CS495xx incorporates a large amount of flexibility into a 144-pin package. The pins are internally multiplexed to serve multiple purposes. Some pins are designed to operate in one mode at power up, and serve a different purpose when the DSP is running. Other pins have functionality which can be controlled by the application running on the DSP. In order to better explain the behavior of the part, the pins which are multiplexed have been given multiple names. Each name is specific to the pin's operation in a particular mode.

4.3.2 Termination Requirements

The CS495xx incorporates open-drain pins which must be pulled high for proper operation. PCP_IRQ# and SCP_IRQ# are always open drain which requires a pull-up for proper operation. The SCP_SDA and SCP_CLK lines are open drain in I²C communication mode.

The specific termination requirements may vary since the state of some of the GPIO pins will determine the communication mode at the rising edge of Reset. For the explicit termination requirements of each communication mode please see the *Typical Connection* diagrams in the *CS495xx Hardware User's Manual*.

Generally a 3.3 k Ω resistor is recommended for open-drain and mode-select pins. A 10 k Ω resistor is sufficient for all other unused inputs.

4.3.3 Pads

The CS495xx has two different I/O voltage levels. All signal pins operate from the 3.3 V supply and are 5 V-tolerant.

4.4 Application Code Security

The external program code is encrypted by the programmer to protect any intellectual property it may contain. A secret, customer-specific key is used to encrypt the program code that is to be stored external to the device.



7. Package Pinout, 144-Pin QFP/LQFP

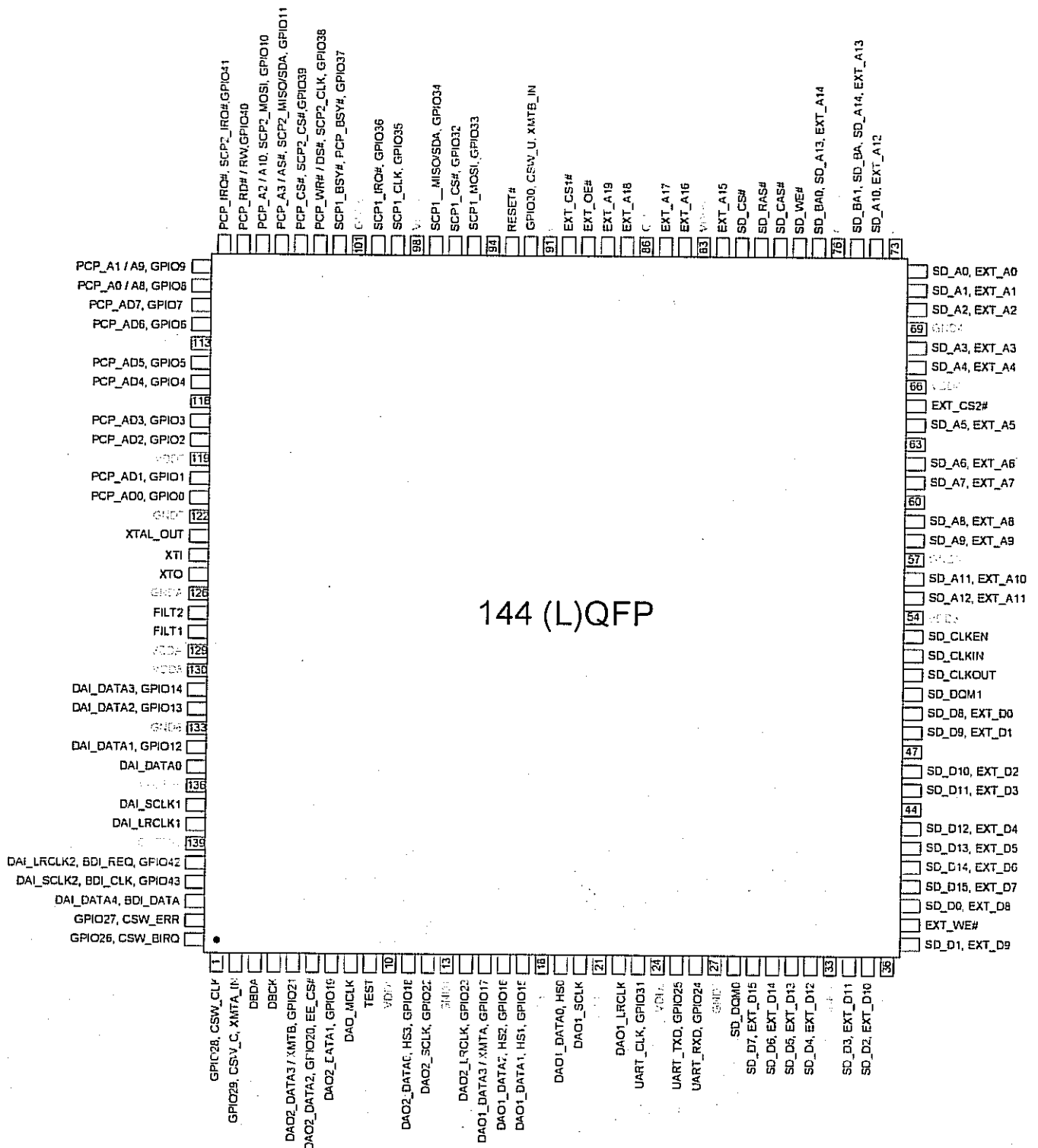

Figure 23. 144-Pin (L)QFP Package Pinout



NJW1321

WIDE BAND VIDEO SWITCH WITH I²C BUS

GENERAL DESCRIPTION

The NJW1321 is a Wide Band Video Switch with I²C BUS.

The NJW1321 includes switch of 4-input 2-output and 6dB amplifier. It is suitable for RGB or Y, Pb, and Pr signal because frequency range is 100MHz.

The NJW1321 includes external logic control terminals and external logic discernment terminals.

The NJW1321 is suitable for PTV, DTV, PDP and other high quality AV systems.

PACKAGE OUTLINE



NJW1321FP1

FEATURES

- Operating Voltage +9.0V
- I²C BUS Interface
- 4-input 2-output 3-Circuits
- Wide frequency range 0dB at 100MHz typ.
-3dB at 300MHz typ.
- Internal 6dB amplifier (Selectable Bypass or 6dB)
- External logic discernment terminal
- External logic control terminal
- Selectable slave address
- Power Save Circuit
- Bi-CMOS Technology
- Package Outline QFP48

BLOCK DIAGRAM

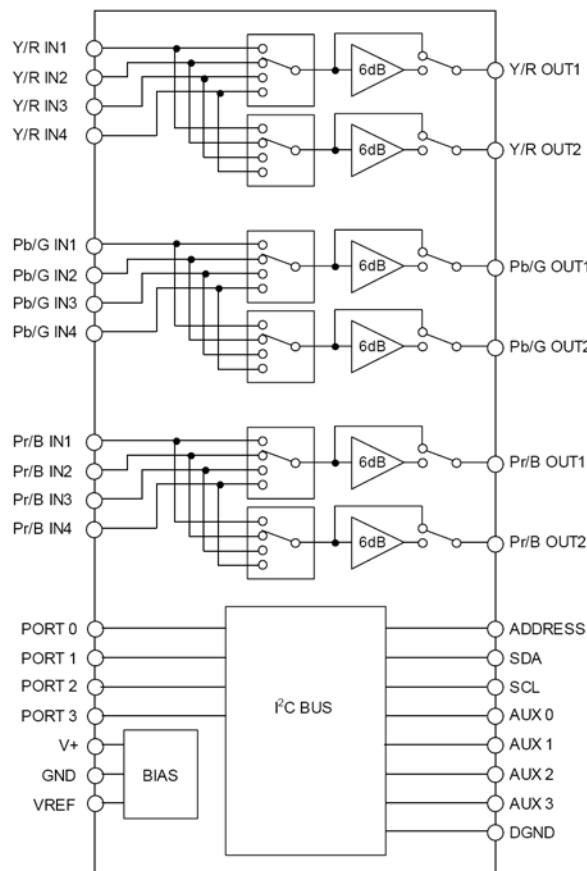

NJW1321

PIN CONFIGURATION

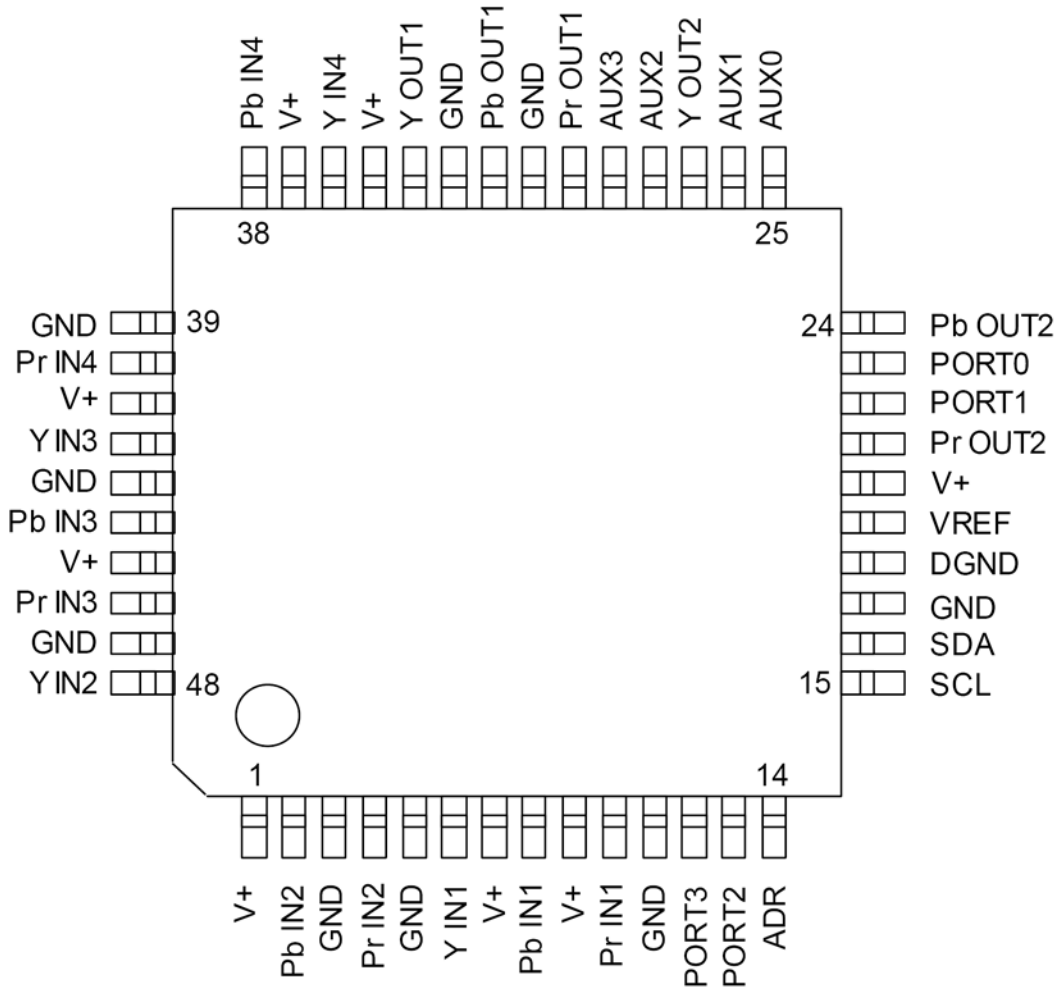

1. V+	13. PORT2	25. AUX0	37. V+
2. Pb IN2	14. ADR	26. AUX1	38. Pb IN4
3. GND	15. SCL	27. Y OUT2	39. GND
4. Pr IN2	16. SDA	28. AUX2	40. Pr IN4
5. GND	17. GND	29. AUX3	41. V+
6. Y IN1	18. DGND	30. Pr OUT1	42. Y IN3
7. V+	19. VREG	31. GND	43. GND
8. Pb IN1	20. V+	32. Pb OUT1	44. Pb IN3
9. V+	21. Pr OUT2	33. GND	45. V+
10. Pr IN1	22. PORT1	34. Y OUT1	46. Pr IN3
11. GND	23. PORT0	35. V+	47. GND
12. PORT3	24. Pb OUT2	36. Y IN4	48. Y IN2

NJW1321

■EQUIVALENT CIRCUIT

PIN No.	NAME	FUNCTION	INSIDE EQUIVALENT CIRCUIT	VOLTAGE
6 8 10 48 2 4 42 44 46 36 38 40	Y IN1 Pb IN1 Pr IN1 Y IN2 Pb IN2 Pr IN2 Y IN3 Pb IN3 Pr IN3 Y IN4 Pb IN4 Pr IN4	Y,Pb,Pr Input RGB Input		4.4V
34 32 30 27 24 21	Y OUT1 Pb OUT1 Pr OUT1 Y OUT2 Pb OUT2 Pr OUT2	Y,Pb,Pr Output RGB Output		3.7V
23 22 13 12	PORT0 PORT1 PORT2 PORT3	Logic input terminal		-
25 26 28 29	AUX0 AUX1 AUX2 AUX3	Auxiliary 3 values voltage output terminal		0V 1.9V 5.0V

NJW1321

PIN No.	NAME	FUNCTION	INSIDE EQUIVALENT CIRCUIT	VOLTAGE
14	ADR	Slave address setting terminal		-
15 16	SCL SDA	I ² C clock terminal I ² C data terminal		-
19	VREF	Reference voltage terminal		4.8V
1 7 9 20 35 37 41 45	V+	Supply voltage terminal		-
3 5 11 17 31 33 39 43 47	GND	Ground terminal		-
18	DGND	Ground terminal		-



NJM2587

6CH VIDEO AMPLIFIER FOR DVD

■GENERAL DESCRIPTION

The NJM2587 is a dual supply voltage 6ch Video Amplifier. It includes 6dB amplifier and 75Ω driver, Low Pass Filter.

The input corresponds to the composite signal, the Y/C signal, and the component signal.

The NJM2587 is suitable for the DVD player and DVD recorder corresponding to the progressive video signal.

■PACKAGE OUTLINE

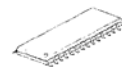

NJM2587V

■FEATURES

- Operating Voltage ±4.5 to ±5.5V
- 6dB amplifier
- Internal LPF
- Internal 75Ω Driver Circuit (2-system drive)
- Power Save Circuit
- Bipolar Technology
- Package Outline SSOP32

■BLOCK DIAGRAM

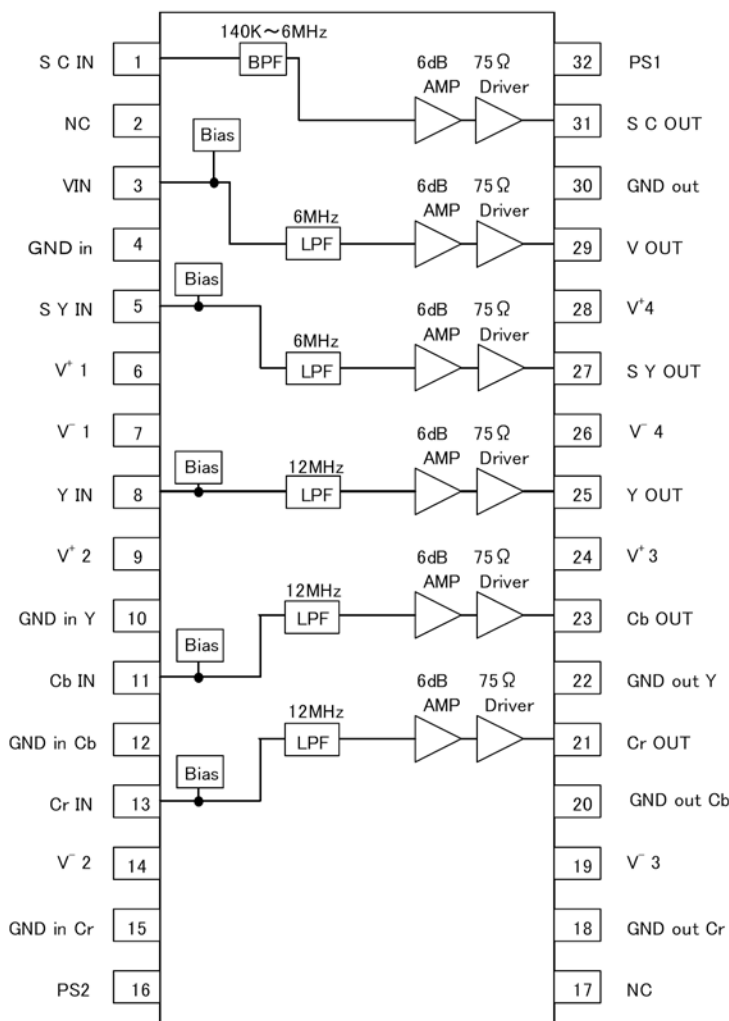



NJM2587

■ TERMINAL DESCRIPTION

No.	SYMBOL	EQUIVALENT CIRCUIT	VOLTAGE	NOTE
1	SCIN		-	
3 5 8 11 13	VIN SYIN YIN CbIN CrIN		0V	
4 10 12 15	GNDIN GNDINY GNDINCb GNDINCr		0V	
18 20 22 30	GNDOUTCr GNDOUTCb GNDOUTY GNDOUT		0V	



NJM2587

No.	SYMBOL	EQUIVALENT CIRCUIT	VOLTAGE	NOTE
25 27 29	YOUT SYOUT VOUT		-0.6V	
31	SCOUT		0.7V	
16 32	PS2 PS1		0V	
21 23	CrOUT CbOUT		-1.2V	

Ordering number : ※EN5039

SANYO	No. ※5039	CMOS IC
		LC74763, 74763M
		On-Screen Display LSI

Preliminary

Overview

The LC74763 and LC74763M are on-screen display CMOS LSIs that superimpose text and low-level graphics onto a TV screen (video signal) under the control of a microcontroller. The display characters have a 12 by 18 dots structure, and 128 characters are provided.

Features

- Display structure: 12 lines by 24 characters (up to 288 characters)
- Maximum character display: Up to 288 characters
- Character configuration: 12 (W) by 18 (H) dots structure
- Number of characters: 128 characters (128 plus space 2 fonts)
- Character sizes: Three sizes (normal, double, and triple sizes)
- Display starting positions: 64 horizontal and 64 vertical locations
- Reverse video function: Characters can be inverted on a per character basis.
- Flashing types: Two types with periods of 0.5 and 1.0 second on a per character basis (duty fixed at 50%)
- Background color: One of eight colors (when internal synchronization used)
- External control input: Serial data input in 8-bit units
- Built-in horizontal/vertical sync separation circuit, AFC circuit, and synchronization detector
- Video output: Composite video signal output in NTSC, PAL, PAL-M, PAL-N, PAL60, NTSC4.43, or SECAM format

Package Dimensions

unit: mm

3196-DIP30SD

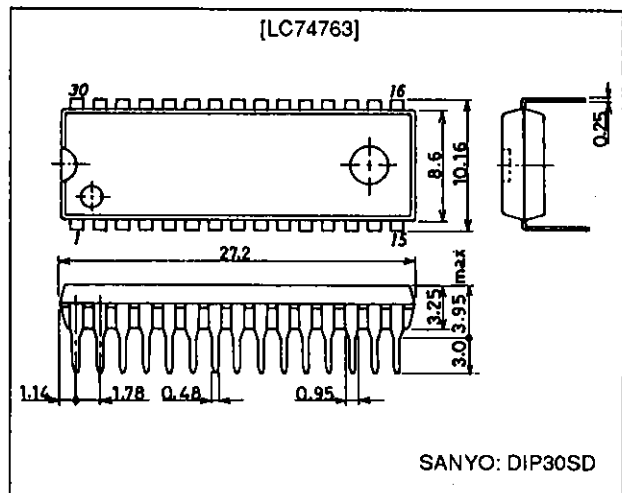

3216A-MFP30S

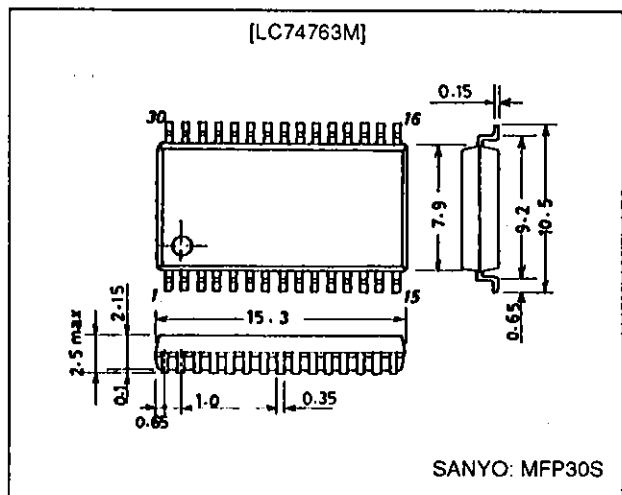

LC74763, 74763M

Pin Functions

Pin No.	Symbol	Function	Description
1	V _{SS}	Ground	Ground connection
2	Xtal _{IN1}	Crystal oscillator connection	Connection for the crystal and capacitor used to form the crystal oscillator that generates the internal synchronization signal. The oscillator can be selected with a command switch.
3	Xtal _{OUT1}		
4	HSYNC _{OUT}	Horizontal synchronization output	Outputs the horizontal synchronization signal (AFC). The output polarity can be selected (metal option). Also functions as general output port (command switch).
5	Xtal _{IN2}	Crystal oscillator connection	Connection for the crystal and capacitor used to form the crystal oscillator that generates the internal synchronization signal.
6	Xtal _{OUT2}		
7	VSYNC _{OUT}	Vertical synchronization output	Outputs the vertical synchronization signal. The output polarity can be selected (metal option). Also functions as general output port (command switch).
8	\overline{CS}	Enable input	Enables/disables serial data input. Serial data is enabled when this pin is low (hysteresis input). Pull-up resistor built in (metal option).
9	SIN	Data input	Serial data input (hysteresis input). Pull-up resistor built in (metal option).
10	SCLK	Clock input	Clock input for serial data input (hysteresis input). Pull-up resistor built in (metal option).
11	SECAM	SECAM mode switch input/output (command switch)	During input, switches between SECAM and other modes. During output, functions as general output port or internal V output (command switch). Low = other modes, high = SECAM mode
12	$\overline{525/625}$	525/625 switch input/output (command switch)	During input, switches between 525 scan lines and 625 scan lines. During output, functions as general output port or character data output (command switch). Low = 525 lines, high = 625 lines
13	$\overline{NTSC/PAL}$	NTSC/PAL switch input/output (command switch)	Switches the color mode between NTSC and PAL. During output, functions as general output port or frame data output (command switch). Low = NTSC, high = PAL
14	$\overline{3.58/4.43}$	3.58/4.43 switch input/output (command switch)	Switch FSC between 3.58 MHz and 4.43 MHz. During output, functions as general output port or halftone output (command switch). Low = 3.58, high = 4.43
15	\overline{RST}	Reset input	System reset input pin, low is active (hysteresis input). Pull-up resistor built in (metal option).
16	CV _{OUT}	Video signal output	Composite video output
17	V _{DD2}	Power supply connection	Power supply connection for composite video signal level generation
18	CV _{IN}	Video signal input	Composite video input
19	CV _{CR}	Video signal input	SECAM chroma signal input
20	SYNC _{IN}	Sync separator circuit input	Built-in sync separator circuit video signal input
21	SEP _C	Sync separator circuit	Built-in sync separator circuit
22	V _{SS}	Ground	Ground connection
23	PD _{OUT}	Control voltage output	AFC control voltage output
24	AMP _{IN}	AFC filter connection	Filter connection
25	AMP _{OUT}		
26	FC	Control voltage input	AFC control voltage input
27	VCO _{IN}	LC oscillator connection	VCO LC oscillator circuit coil and capacitor connection
28	VCO _{OUT}		
29	SYNC _{DET}	External synchronization signal detection output	Outputs the exclusive NOR of the horizontal synchronization signal (AFC) and CSYNC (sync separator). The output polarity can be selected (metal option). Also functions as general output port (command switch).
30	V _{DD1}	Power supply connection	Power supply connection (+5 V; digital system power supply)

LC74763, 74763M

Pin Assignment

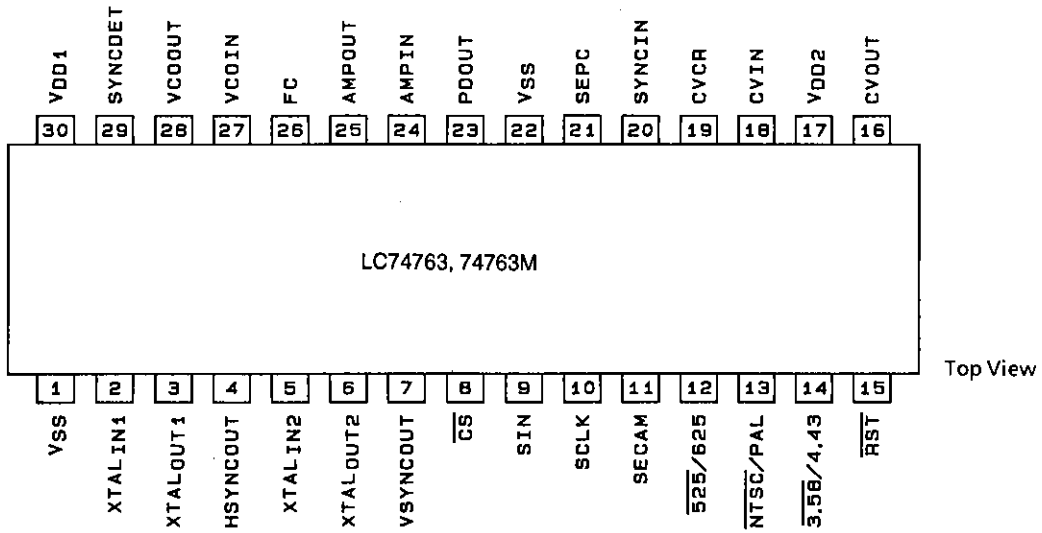

A03518

Serial Data Input Timing

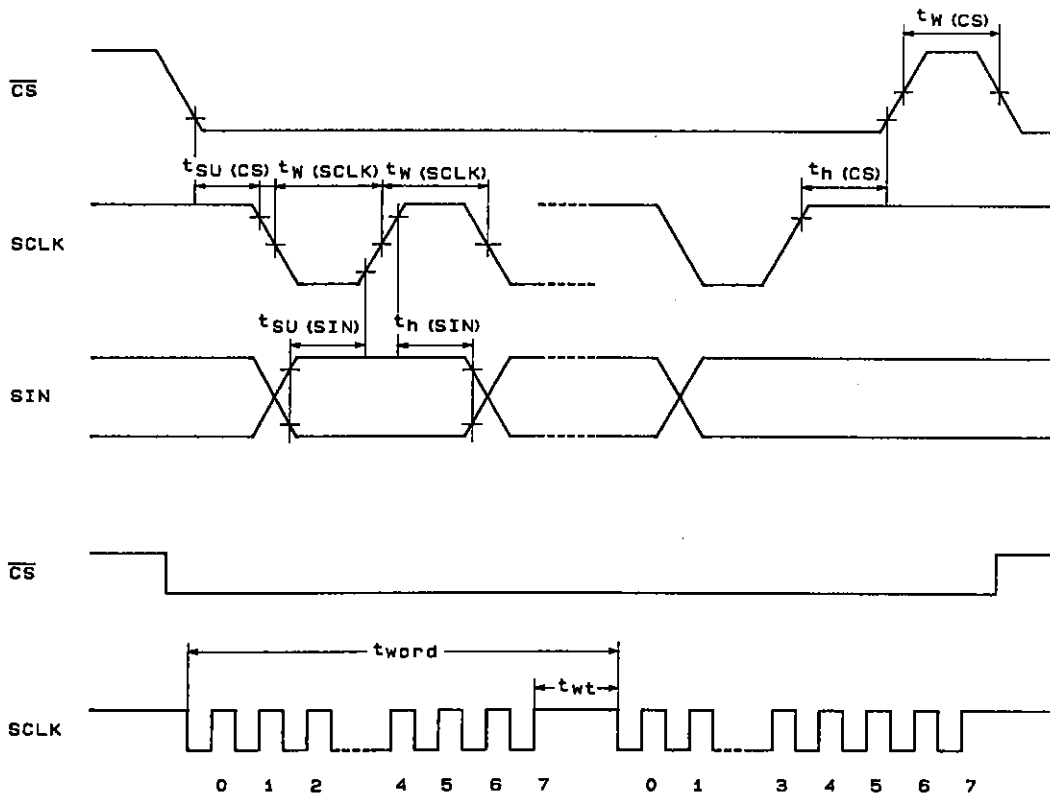

A03519

LC74763, 74763M

System Block Diagram

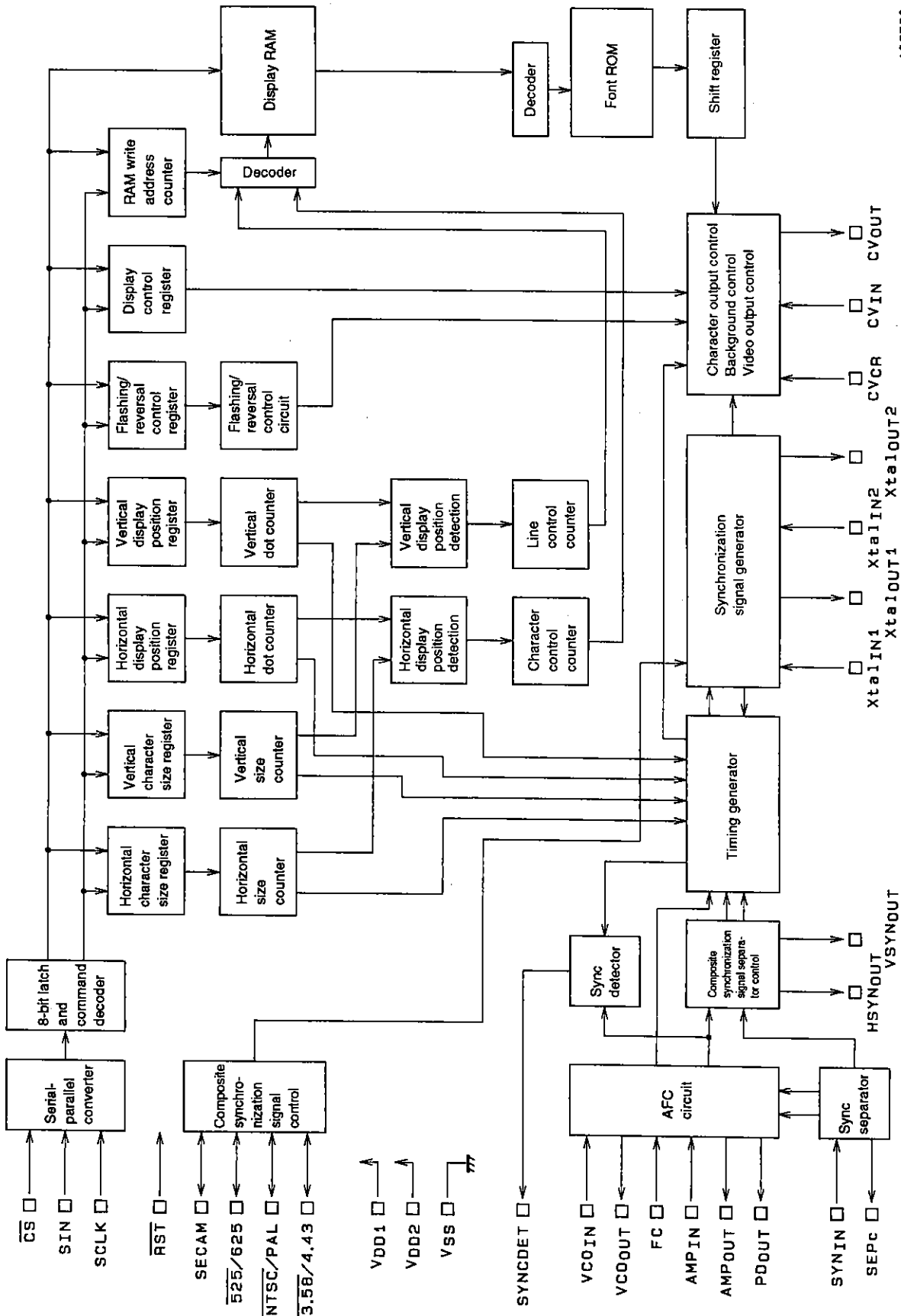

403520



Sil 9185

Three Input, Single Output Deep Color HDMI Switch

Data Sheet

Silicon Image, Inc.

Sil 9185 Pin Mapping

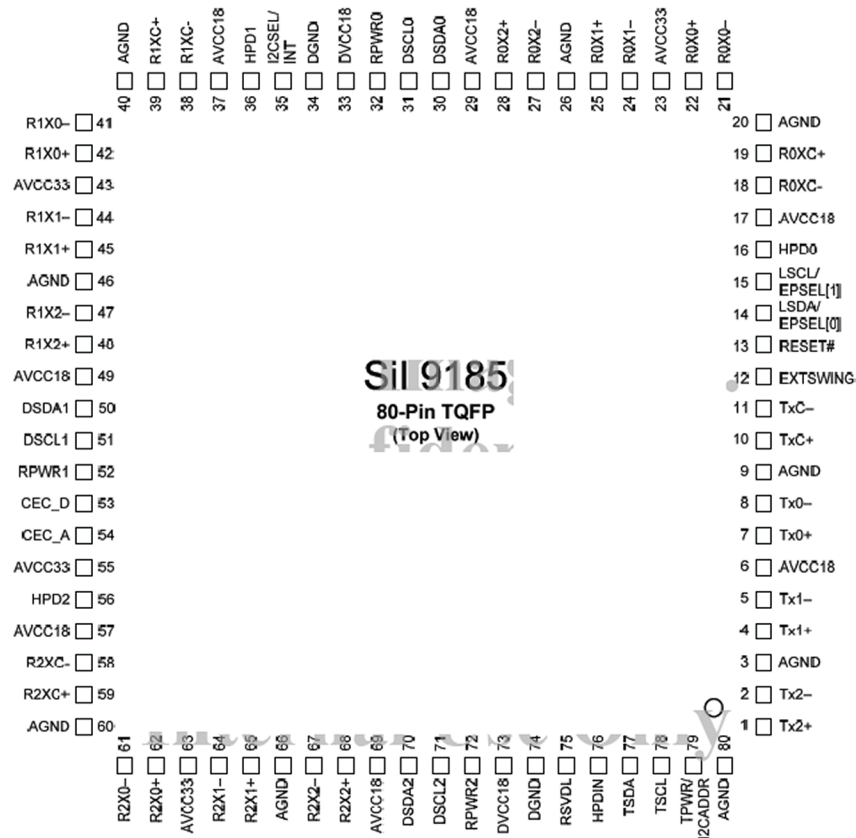

**Sil 9185 Three Input, Single Output Deep Color HDMI Switch
Data Sheet**

Silicon Image, Inc.

Block Level Functionality

The Sil 9185 Three Input, Single Output Deep Color HDMI Switch is used to select a single set of HDMI/DVI signals from one of three HDMI/DVI receiver-ports, and to generate a fully compliant HDMI/DVI stream as an output. It also provides DDC/HDCP, HPD, and +5V switching to allow full compliance to the HDMI/DVI Specification.

The combination of programmable equalizer and state-of-the-art DPLL can overcome signal distortion due to the long lengths of HDMI/DVI cables. Sil 9185-based switches can be cascaded many times to regenerate TMDS and HDCP signals.

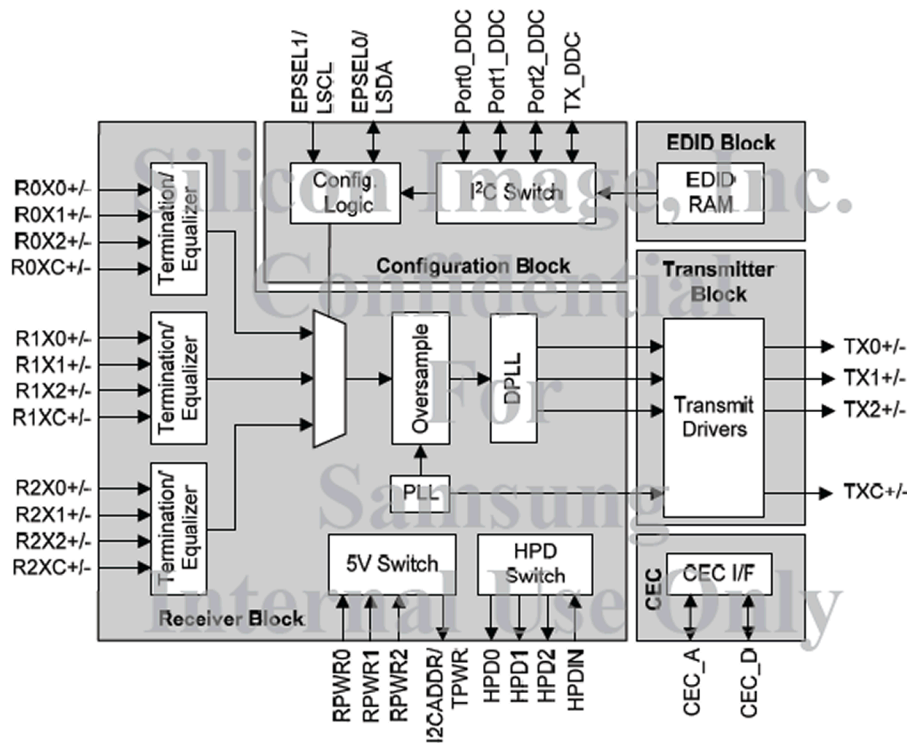

Figure 3. Functional Block Diagram

As shown in Figure 3, the Sil 9185 consists of five major blocks:

- Receiver block
- Transmitter block
- CEC Interface block
- EDID RAM block
- Configuration Block

ES29LV320E

32Mbit(4M x 8/2M x 16)

CMOS 3.0 Volt-only, Boot Sector Flash Memory

GENERAL FEATURES

- **Single power supply operation**
 - 2.7V ~ 3.6V for read, program and erase operations
- **Sector Structure**
 - 8Kbyte x 8 boot sectors
 - 64Kbyte x 63 sectors
 - 256byte security sector
- **Top or Bottom boot block**
 - ES29LV320ET for Top boot block device
 - ES29LV320EB for Bottom boot block device
- **A 256 bytes of extra sector for security code**
 - Factory locked
 - Customer lockable
- **Package Options**
 - 48-pin TSOP
 - 48-ball FBGA
 - Pb-free packages
 - All Pb-free products are RoHS-Compliant
- **Low Vcc write inhibit**
- **Manufactured on 0.18um process technology**
- **Compatible with JEDEC standards**
 - Pinout and software compatible with single-power supply flash standard

DEVICE PERFORMANCE

- **Read access time**
 - 70ns/90ns for normal Vcc range (2.7V ~ 3.6V)
- **Program and erase time**
 - Program time : 6us/byte, 8us/word (typical)
 - Accelerated program time : 4us/word (typical)
 - Sector erase time : 0.7sec/sector (typical)
- **Power consumption (typical values)**
 - 15uA in standby or automatic sleep mode
 - 10mA active read current at 5MHz
 - 15mA active write current during program or erase

- **Minimum 100,000 program/erase cycles per sector**
- **20 Year data retention at 125°C**

SOFTWARE FEATURES

- **Erase Suspend / Erase Resume**
- **Data# poll and toggle for Program/erase status**
- **CFI (Common Flash Interface) supported**
- **Unlock Bypass Program**
- **Autoselect mode**
- **Auto-sleep mode after t_{ACC} + 30ns**

HARDWARE FEATURES

- **Hardware reset input pin (RESET#)**
 - Provides a hardware reset to device
 - Any internal device operation is terminated and the device returns to read mode by the reset
- **Ready/Busy# output pin (RY/BY#)**
 - Provides a program or erase operational status about whether it is finished for read or still being progressed
- **WP#/ACC input pin**
 - Two outermost boot sectors are protected when WP# is set to low, regardless of sector protection
 - Program speed is accelerated by raising WP#/ACC to a high voltage (11.5V~12.5V)
- **Sector protection / unprotection (RESET# , A9)**
 - Hardware method of locking a sector to prevent any program or erase operation within that sector
 - Two methods are provided :
 - In-system method by RESET# pin
 - A9 high-voltage method for PROM programmers
- **Temporary Sector Unprotection (RESET#)**
 - Allows temporary unprotection of previously protected sectors to change data in-system

GENERAL PRODUCT DESCRIPTION

The ES29LV320 is a 32 megabit, 3.0 volt-only flash memory device, organized as 4M x 8 bits (Byte mode) or 2M x 16 bits (Word mode) which is configurable by BYTE#. Eight boot sectors and sixty three main sectors with uniform size are provided : 8Kbytes x 8 and 64Kbytes x 63. The device is manufactured with ESI's proprietary, high performance and highly reliable 0.18um CMOS flash technology. The device can be programmed or erased in-system with standard 3.0 Volt Vcc supply (2.7V~3.6V) and can also be programmed in standard EPROM programmers. The device offers minimum endurance of 100,000 program/erase cycles and more than 10 years of data retention.

The ES29LV320 offers access time as fast as 70ns or 90ns, allowing operation of high-speed microprocessors without wait states. Three separate control pins are provided to eliminate bus contention : chip enable (CE#), write enable (WE#) and output enable (OE#).

All program and erase operation are automatically and internally performed and controlled by embedded program/erase algorithms built in the device. The device automatically generates and times the necessary high-voltage pulses to be applied to the cells, performs the verification, and counts the number of sequences. Some status bits (DQ7, DQ6 and DQ5) read by data# polling or toggling between consecutive read cycles provide to the users the internal status of program/erase operation: whether it is successfully done or still being progressed.

Extra Security Sector of 256 bytes

In the device, an extra security sector of 256 bytes is provided to customers. This extra sector can be used for various purposes such as storing ESN (Electronic Serial Number) or customer's security codes. Once after the extra sector is written, it can be permanently locked by the device manufacturer (**factory-locked**) or a customer(**customer-lockble**). At the same time, a **lock indicator bit (DQ7)** is permanently set to a 1 if the part is factory- locked, or set to 0 if it is customer-lockable. Therefore, this lock indicator bit (DQ7) can be properly used to avoid that any customer-lockable part is used to replace a factory-locked part. The extra security sector is an extra memory space for customers when it is used as a customer-lockable version. So, it can be read and written like any other sectors. But it should be noted that the number of E/W(Erase and Write) cycles is limited to 300 times (maximum) only in the Security Sector.

Special services such as ESN and factory-lock are available to customers (ESI's **Special-Code service**) The ES29LV320 is completely compatible with the JEDEC standard command set of single power supply Flash. Commands are written to the internal command register using standard write timings of microprocessor and data can be read out from the cell array in the device with the same way as used in other EPROM or flash devices.

PRODUCT SELECTOR GUIDE

Family Part Number	ES29LV320E	
Voltage Range	2.7V ~ 3.6 V	
Speed Option	70	90
Max Access Time (ns)	70	90
CE# Access (ns)	70	90
OE# Access (ns)	30	40

FUNCTION BLOCK DIAGRAM

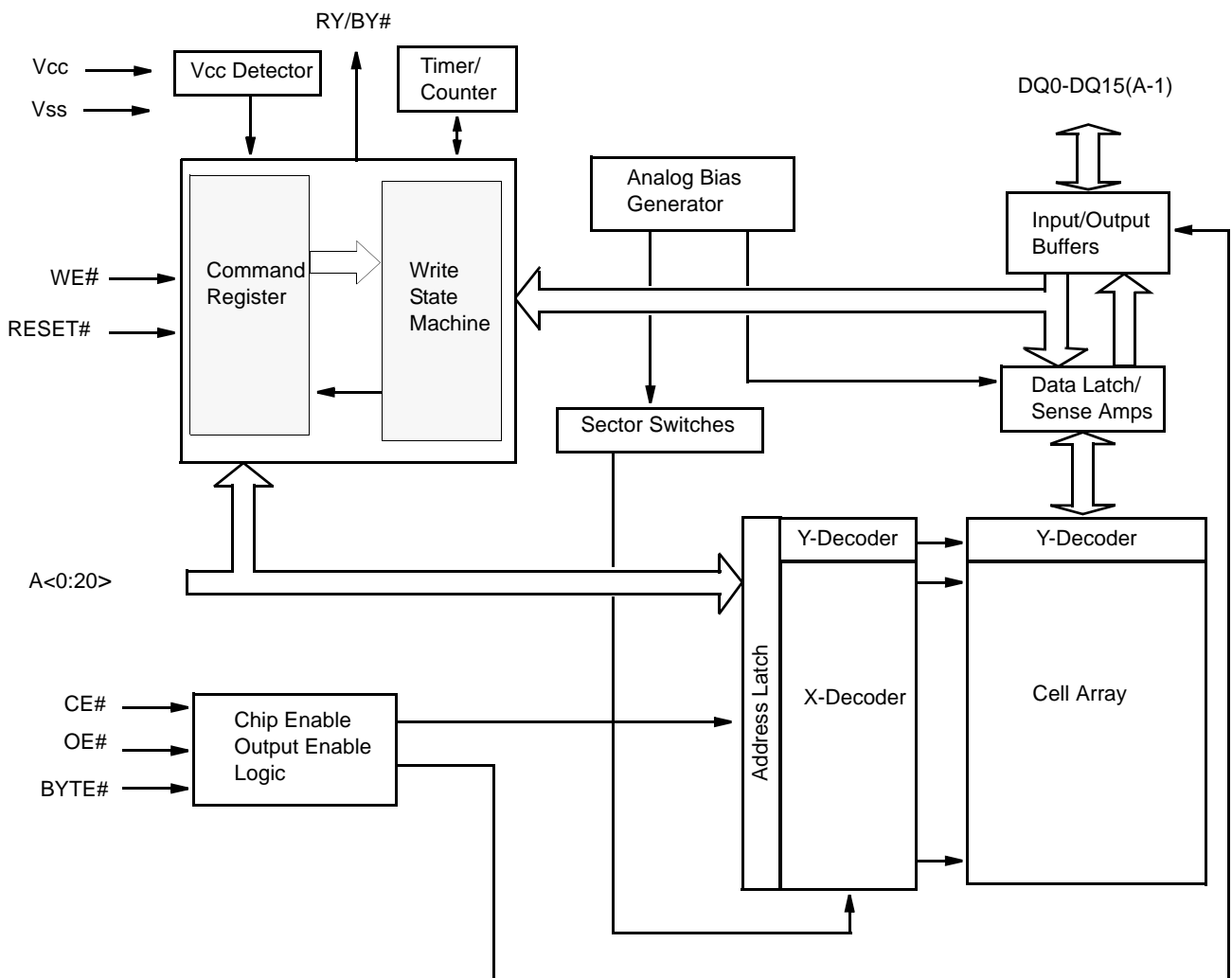

PIN DESCRIPTION

Pin	Description
A0-A20	21 Addresses
DQ0-DQ14	15 Data Inputs/Outputs
DQ15/A-1	DQ15 (Data Input/Output, Word Mode) A-1 (LSB Address Input, Byte Mode)
CE#	Chip Enable
OE#	Output Enable
WE#	Write Enable
WP#/ACC	Hardware Write Protect/Acceleration Pin
RESET#	Hardware Reset Pin, Active Low
BYTE#	Selects 8-bit or 16-bit mode
RY/BY#	Ready/Busy Output
Vcc	3.0 volt-only single power supply (see Product Selector Guide for speed options and voltage supply tolerances)
Vss	Device Ground
NC	Pin Not Connected Internally

LOGIC SYMBOL

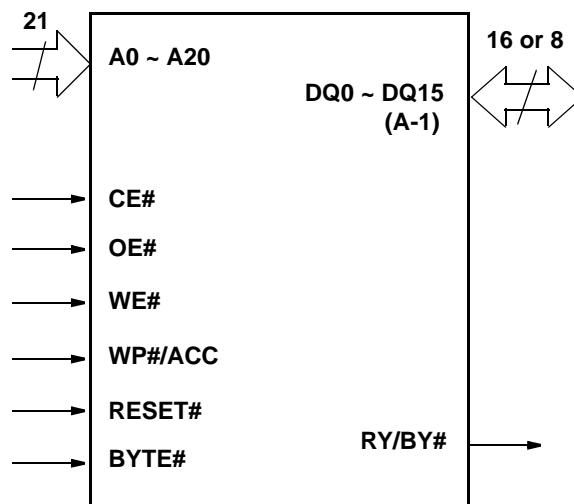

CONNECTION DIAGRAM



48-Ball FBGA 6 x 8 mm)
(Top View, Balls Facing Down)

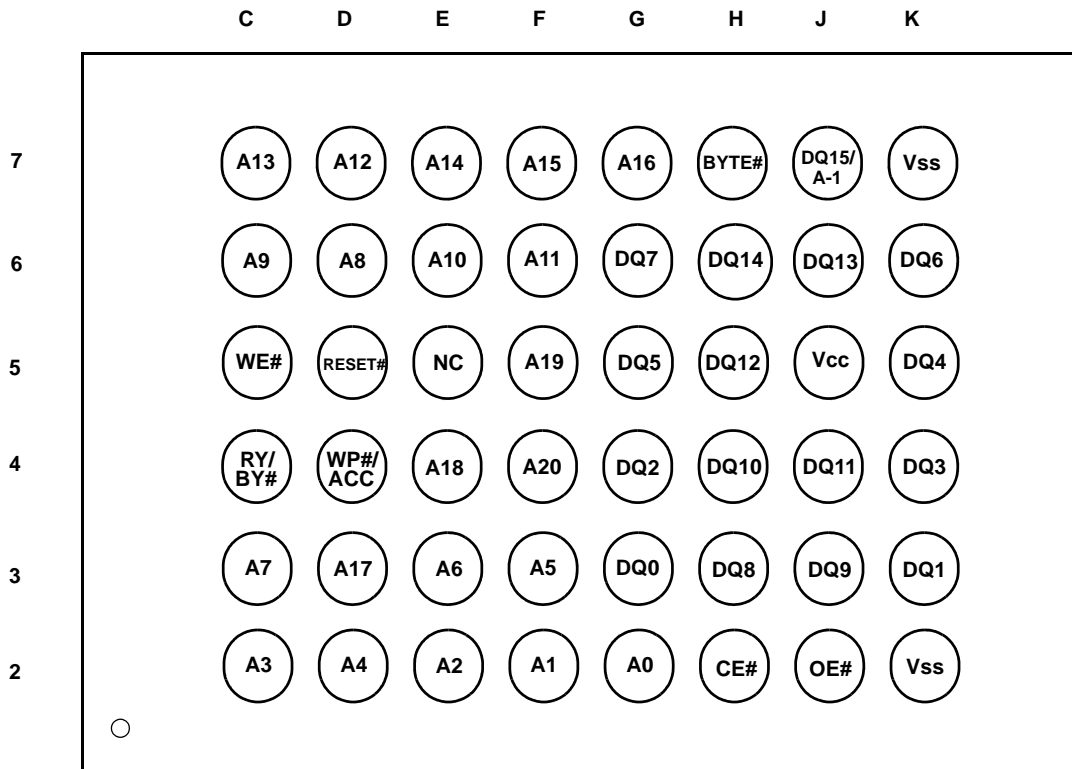

ESMT

M12L16161A

SDRAM

512K x 16Bit x 2Banks Synchronous DRAM

FEATURES

- JEDEC standard 3.3V power supply
- LVTTTL compatible with multiplexed address
- Dual banks operation
- MRS cycle with address key programs
 - CAS Latency (2 & 3)
 - Burst Length (1, 2, 4, 8 & full page)
 - Burst Type (Sequential & Interleave)
- All inputs are sampled at the positive going edge of the system clock
- Burst Read Single-bit Write operation
- DQM for masking
- Auto & self refresh
- 32ms refresh period (2K cycle)

GENERAL DESCRIPTION

The M12L16161A is 16,777,216 bits synchronous high data rate Dynamic RAM organized as 2 x 524,288 words by 16 bits, fabricated with high performance CMOS technology. Synchronous design allows precise cycle control with the use of system clock I/O transactions are possible on every clock cycle. Range of operating frequencies, programmable burst length and programmable latencies allow the same device to be useful for a variety of high bandwidth, high performance memory system applications.

ORDERING INFORMATION

Part NO.	MAX Freq.	PACKAGE	COMMENTS
M12L16161A-5TG	200MHz	TSOP(II)	Pb-free
M12L16161A-7TG	143MHz	TSOP(II)	Pb-free
M12L16161A-7BG	143MHz	VFBGA	Pb-free

PIN CONFIGURATION (TOP VIEW)

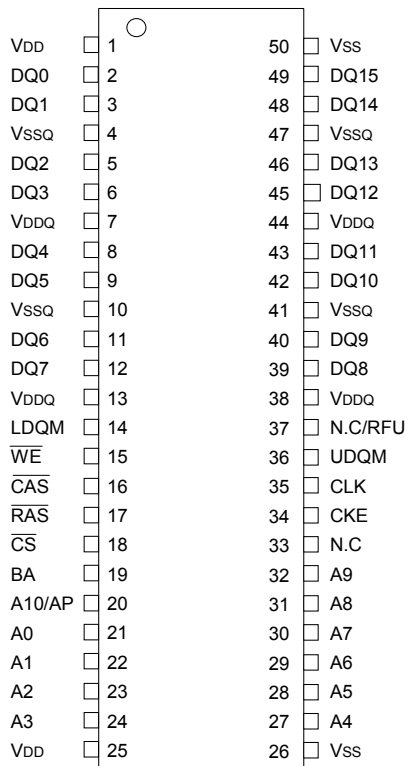

50PIN TSOP(II)
(400mil x 825mil)
(0.8 mm PIN PITCH)

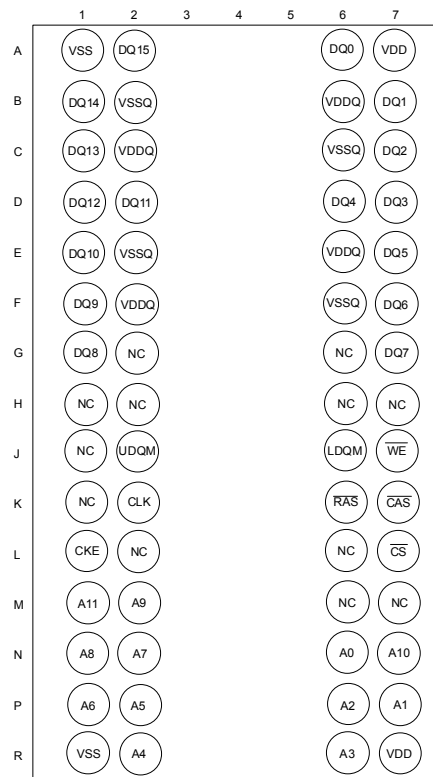

60 Ball VFBGA
(6.4x10.1mm)
(0.65mm ball pitch)

ESMT

M12L16161A

FUNCTIONAL BLOCK DIAGRAM

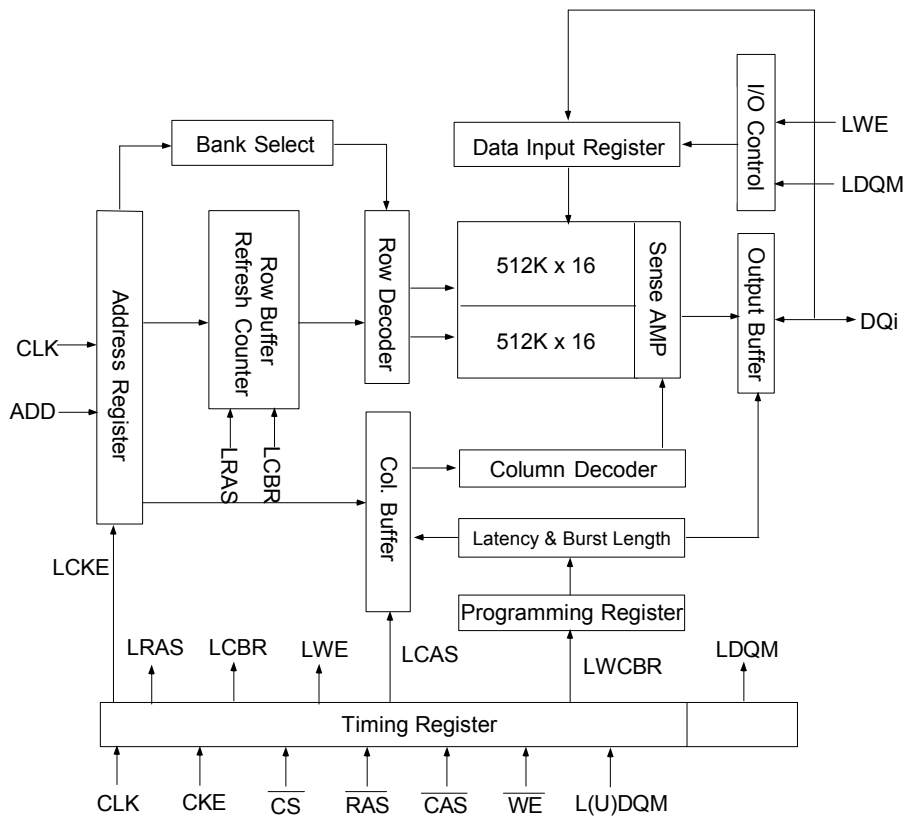

PIN FUNCTION DESCRIPTION

Pin	Name	Input Function
CLK	System Clock	Active on the positive going edge to sample all inputs.
\overline{CS}	Chip Select	Disables or enables device operation by masking or enabling all inputs except CLK, CKE and L(U)DQM.
CKE	Clock Enable	Masks system clock to freeze operation from the next clock cycle. CKE should be enabled at least one cycle prior to new command. Disable input buffers for power down in standby.
A0 ~ A10/AP	Address	Row / column addresses are multiplexed on the same pins. Row address : RA0 ~ RA10, column address : CA0 ~ CA7
BA	Bank Select Address	Selects bank to be activated during row address latch time. Selects bank for read/write during column address latch time.
\overline{RAS}	Row Address Strobe	Latches row addresses on the positive going edge of the CLK with \overline{RAS} low. Enables row access & precharge.
\overline{CAS}	Column Address Strobe	Latches column addresses on the positive going edge of the CLK with \overline{CAS} low. Enables column access.
\overline{WE}	Write Enable	Enables write operation and row precharge. Latches data in starting from \overline{CAS} , \overline{WE} active.
L(U)DQM	Data Input / Output Mask	Makes data output Hi-Z, tSHZ after the clock and masks the output. Blocks data input when L(U)DQM active.
DQ0 ~ 15	Data Input / Output	Data inputs/outputs are multiplexed on the same pins.
VDD/VSS	Power Supply/Ground	Power and ground for the input buffers and the core logic.
VDDQ/VSSQ	Data Output Power/Ground	Isolated power supply and ground for the output buffers to provide improved noise immunity.
N.C/RFU	No Connection/ Reserved for Future Use	This pin is recommended to be left No Connection on the device.

TOSHIBA

TC74HCU04AP/AF/AFN

TOSHIBA CMOS DIGITAL INTEGRATED CIRCUIT SILICON MONOLITHIC

TC74HCU04AP, TC74HCU04AF, TC74HCU04AFN

HEX INVERTER

The TC74HCU04A is a high speed CMOS INVERTER fabricated with silicon gate C²MOS technology. It achieves the high speed operation similar to equivalent LSTTL while maintaining the CMOS low power dissipation. Since the internal circuit is composed of a single stage inverter, it can be used in analog applications such as crystal oscillators. All inputs are equipped with protection circuits against static discharge or transient excess voltage.

FEATURES :

- High Speed..... $t_{pd} = 4ns(\text{typ.})$ at $V_{CC} = 5V$
- Low Power Dissipation..... $I_{CC} = 1\mu A(\text{Max.})$ at $T_a = 25^\circ C$
- High Noise Immunity..... $V_{NIH} = V_{NIH} = 10\%V_{CC}$ (Min.)
- Output Drive Capability..... 10 LSTTL Loads
- Symmetrical Output Impedance... $|I_{OH}| = I_{OL} = 4mA(\text{Min.})$
- Balanced Propagation Delays..... $t_{pLH} \approx t_{pHL}$
- Wide Operating Voltage Range... $V_{CC}(\text{opr.}) = 2V \sim 6V$
- Pin and Function Compatible with 74LS04

(Note) The JEDEC SOP (FN) is not available in Japan.

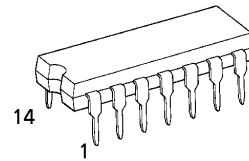

P (DIP14-P-300-2.54)
Weight : 0.96g (Typ.)

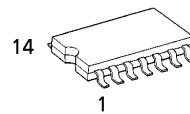

F (SOP14-P-300-1.27)
Weight : 0.18g (Typ.)

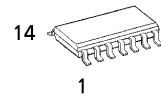

FN (SOL14-P-150-1.27)
Weight : 0.12g (Typ.)

PIN ASSIGNMENT

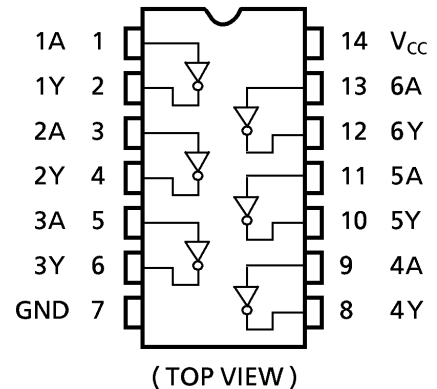

IEC LOGIC SYMBOL

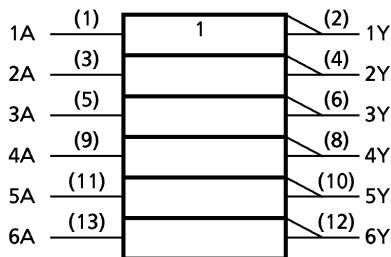

TRUTH TABLE

A	Y
L	H
H	L

NJW1197FC2 [8-CHANNEL ELECTRONIC VOLUME WITH INPUT SELECTOR]

[STRUCTURE] Bi-CMOS
 [CATEGORIES] 3D Surround & Sound Enhancement
 [PACKAGE OUTLINE] QFP100-C2
 [SOLDERING METHOD] For this device, soldering method is recommended Reflow.
 [NOTE] -

BAE-45919-000-00

■ **ABSOLUTE MAXIMUM RATINGS** $T_a=25^\circ\text{C}$

Power Supply Voltage +8/-8 [V]	Operating Temperature Range -40 to +75 [°C]
Maximum Input Voltage V^+/V^- [V]	Storage Temperature Range -40 to +150 [°C]
Power Dissipation 1600 [mW] (Note)	

(Note) EIA/JEDEC STANDARD Test board (76.2 × 114.3 × 1.6mm, 2layer, FR-4) mounting.

■ **BLOCK DIAGRAM**

BDE-45919-000-00

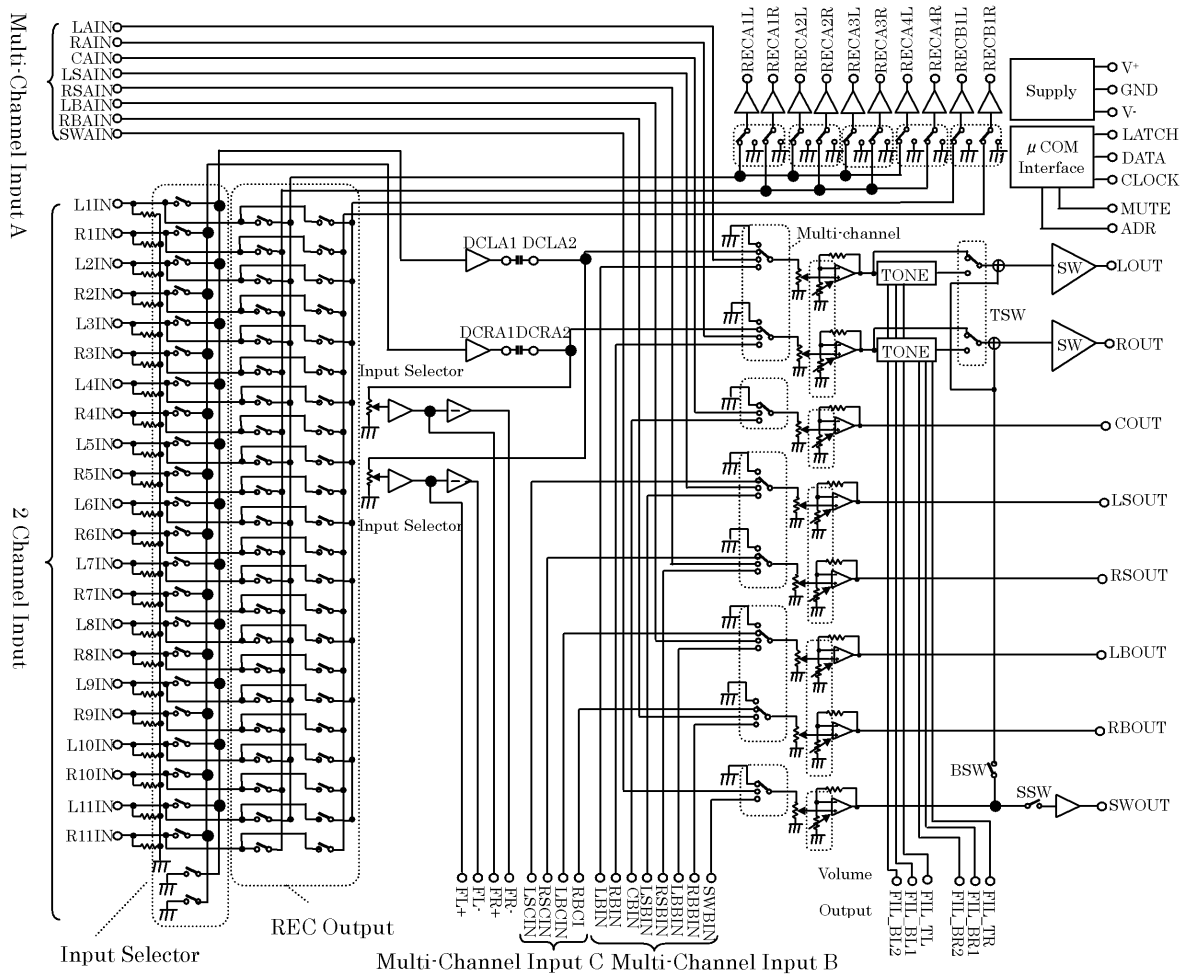

■ PIN CONFIGURAITON

BEE-45919-000-00

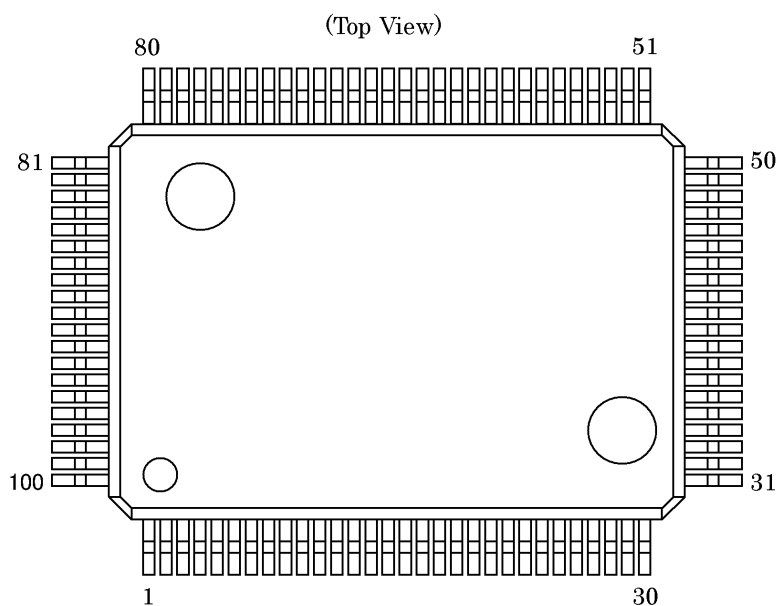

No.	SYMBOL	No.	SYMBOL	No.	SYMBOL	No.	SYMBOL
1	ROUT	26	DCCAP_RS	51	DCR_IN	76	GND
2	COUT	27	L3IN	52	DCR_OUT	77	LSCIN
3	LSOUT	28	DCCAP_LS	53	GND	78	RSCIN
4	RSOUT	29	R3IN	54	DCL_IN	79	LBCIN
5	LBOUT	30	DCCAP_C	55	DCL_OUT	80	RBCIN
6	RBOUT	31	L4IN	56	GND	81	GND
7	SWOUT	32	DCCAP_R	57	REC_B1R	82	LAIN
8	GND	33	R4IN	58	REC_B1L	83	RAIN
9	FIL_BL2	34	DCCAP_L	59	REC_A4R	84	CAIN
10	FIL_BL1	35	L5IN	60	REC_A4L	85	LSAIN
11	FIL_TL	36	GND	61	REC_A3R	86	RSAIN
12	TCAP	37	R5IN	62	REC_A3L	87	LBAIN
13	FIL_BR2	38	GND	63	REC_A2R	88	RBAIN
14	FIL_BR1	39	L6IN	64	REC_A2L	89	SWAIN
15	FIL_TR	40	L9IN	65	REC_A1R	90	GND
16	V ⁺	41	R6IN	66	REC_A1L	91	LBIN
17	ADR	42	R9IN	67	VDDOUT	92	RBIN
18	V ⁻	43	L7IN	68	DATA	93	CBIN
19	L1IN	44	L10IN	69	CLOCK	94	LSBIN
20	DCCAP_SW	45	R7IN	70	LATCH	95	RSBIN
21	R1IN	46	R10IN	71	MUTE	96	LBBIN
22	DCCAP_RB	47	L8IN	72	FL ⁺	97	RBBIN
23	L2IN	48	L11IN	73	FL ⁻	98	SWBIN
24	DCCAP_LB	49	R8IN	74	FR ⁺	99	GND
25	R2IN	50	R11IN	75	FR ⁻	100	LOUT

FUNCTIONAL DESCRIPTION

BGE-45919-000-00

(1) CONTROL DATA

NJW1197 control data is constructed with 16bits.

	MSB														LSB
D15	D14	D13	D12	D11	D10	D9	D8	D7	D6	D5	D4	D3	D2	D1	D0
Data								Select Address				Chip Address			

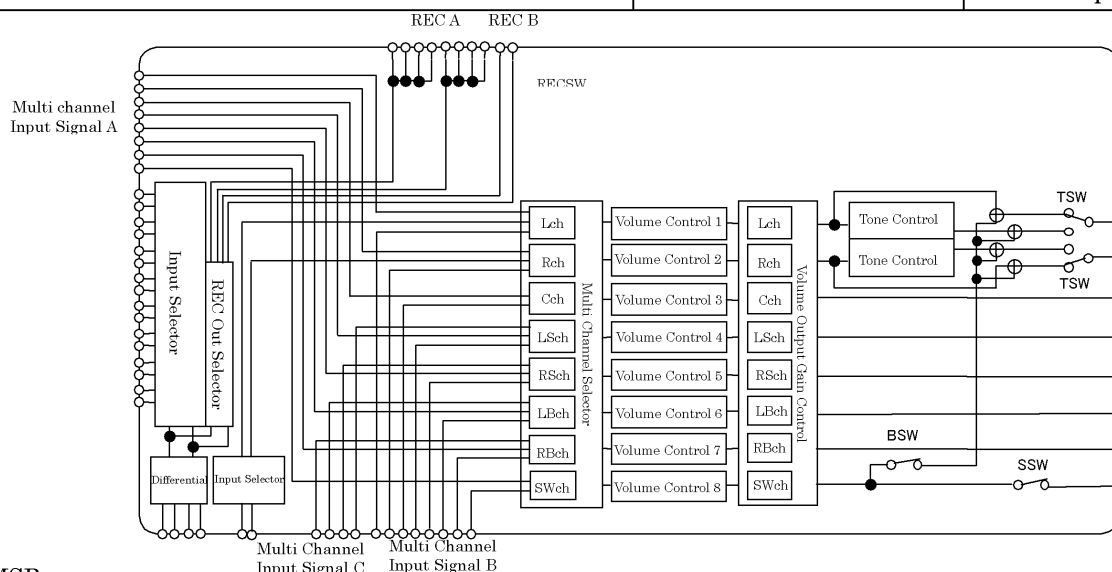

MSB LSB

D15	D14	D13	D12	D11	D10	D9	D8	D7	D6	D5	D4	D3	D2	D1	D0
L channel Volume Control								0	0	0	0	*	*	*	*
R channel Volume Control								0	0	0	1	*	*	*	*
C channel Volume Control								0	0	1	0	*	*	*	*
LS channel Volume Control								0	0	1	1	*	*	*	*
RS channel Volume Control								0	1	0	0	*	*	*	*
LB channel Volume Control								0	1	0	1	*	*	*	*
RB channel Volume Control								0	1	1	0	*	*	*	*
SW channel Volume Control								0	1	1	1	*	*	*	*
Input Selector Gain Control		Input Selector					SSW	1	0	0	0	*	*	*	*
TC/B	Tone Control Treble				TSW	BSW	*	1	0	0	1	*	*	*	*
BC/B	Tone Control Bass				*	*	*	1	0	1	0	*	*	*	*
REC B Selector				Input Selector				1	0	1	1	*	*	*	*
SWch Volume Output Gain Control		REC B1	REC A4	REC A3	REC A2	REC A1	1	1	0	0	*	*	*	*	
L, Rch Volume Output Gain Control		Cch, Volume Output Gain Control			*	*	1	1	0	1	*	*	*	*	
LS, RSch Volume Output Gain Control		LB, RBch Volume Output Gain Control		SWch Selector		1	1	1	0	*	*	*	*		
L, Rch Selector	Cch Selector	LS, RSch Selector		LB, RBch Selector		1	1	1	1	*	*	*	*		

*: Don't Care

* Chip address is set by chip address select terminal (ADR) status.

Chip Address Select Terminal (ADR: 17pin)	Chip Address			
	D3	D2	D1	D0
Low	0	1	0	0
High	0	1	0	1

* The mute function can be controlled externally. If the Mute control terminal (71pin) is switched to High, Multi-Channel outputs are muted immediately (hardware mute).

External mute control terminal (MUTE: 71pin)	Setting
Low	Mute cancellation
High	Mute



M24C64

M24C32

64Kbit and 32Kbit Serial I²C Bus EEPROM

FEATURES SUMMARY

- Two-Wire I²C Serial Interface
Supports 400kHz Protocol
- Single Supply Voltage:
 - 4.5 to 5.5V for M24Cxx
 - 2.5 to 5.5V for M24Cxx-W
 - 1.8 to 5.5V for M24Cxx-R
- Write Control Input
- BYTE and PAGE WRITE (up to 32 Bytes)
- RANDOM and SEQUENTIAL READ Modes
- Self-Timed Programming Cycle
- Automatic Address Incrementing
- Enhanced ESD/Latch-Up Protection
- More than 1 Million Erase/Write Cycles
- More than 40-Year Data Retention

Table 1. Product List

Reference	Part Number
M24C64	M24C64
	M24C64-W
	M24C64-R
M24C32	M24C32
	M24C32-W
	M24C32-R

Figure 1. Packages

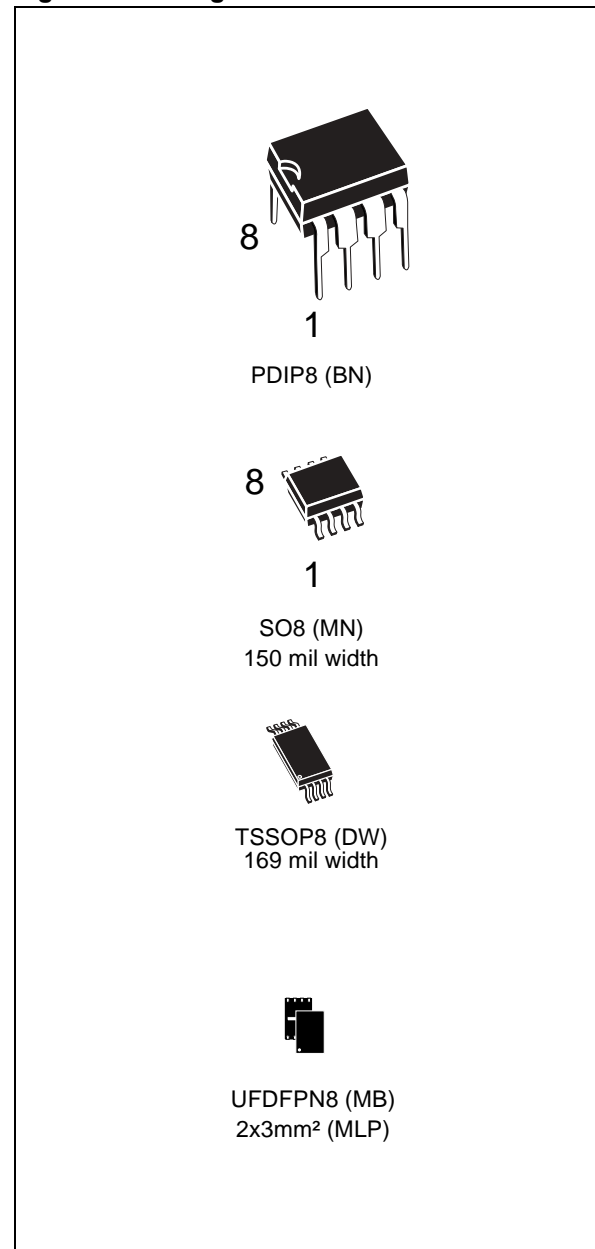

M24C64, M24C32

SUMMARY DESCRIPTION

These I²C-compatible electrically erasable programmable memory (EEPROM) devices are organized as 8192 x 8 bits (M24C64) and 4096 x 8 bits (M24C32).

Figure 2. Logic Diagram

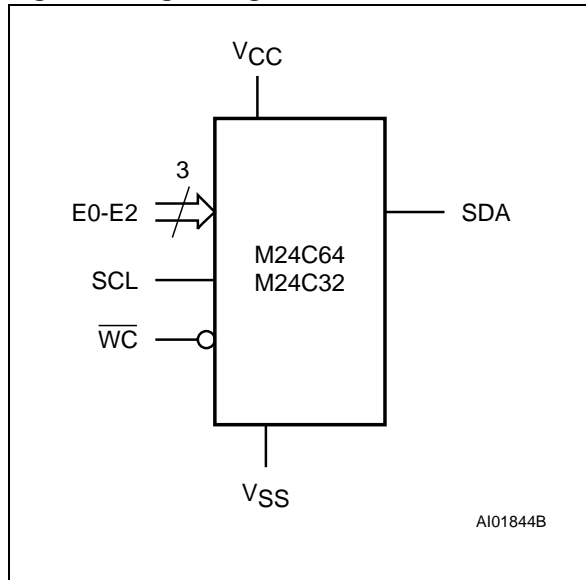

I²C uses a two-wire serial interface, comprising a bi-directional data line and a clock line. The devices carry a built-in 4-bit Device Type Identifier code (1010) in accordance with the I²C bus definition.

The device behaves as a slave in the I²C protocol, with all memory operations synchronized by the serial clock. Read and Write operations are initiated by a Start condition, generated by the bus master. The Start condition is followed by a Device Select Code and Read/Write bit (RW) (as described in Table 3.), terminated by an acknowledge bit.

When writing data to the memory, the device inserts an acknowledge bit during the 9th bit time, following the bus master's 8-bit transmission. When data is read by the bus master, the bus master acknowledges the receipt of the data byte in the same way. Data transfers are terminated by a Stop condition after an Ack for Write, and after a NoAck for Read.

Table 2. Signal Names

E0, E1, E2	Chip Enable
SDA	Serial Data
SCL	Serial Clock
\overline{WC}	Write Control
VCC	Supply Voltage
VSS	Ground

Power On Reset: VCC Lock-Out Write Protect

In order to prevent data corruption and inadvertent Write operations during Power-up, a Power On Reset (POR) circuit is included. At Power-up, the internal reset is held active until VCC has reached the Power On Reset (POR) threshold voltage, and all operations are disabled – the device will not respond to any command. In the same way, when VCC drops from the operating voltage, below the Power On Reset (POR) threshold voltage, all operations are disabled and the device will not respond to any command.

A stable and valid VCC (as defined in Table 9. and Table 10.) must be applied before applying any logic signal.

Figure 3. DIP, SO, TSSOP and UDFPN Connections

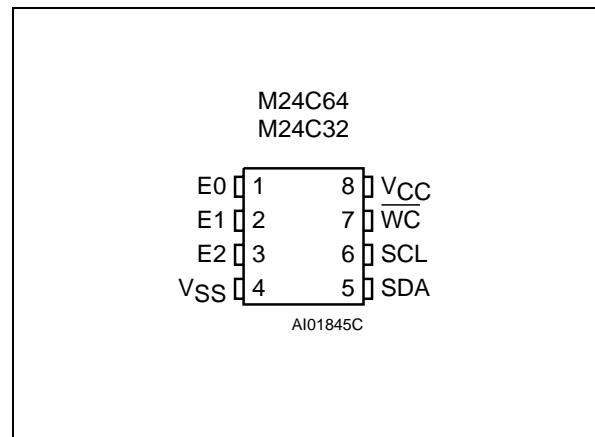

Note: See PACKAGE MECHANICAL section for package dimensions, and how to identify pin-1.

CMOS 16-Bit Microcontrollers

T5CC1

1. Outline and Features

T5CC1 is a high-speed 16-bit microcontroller designed for the control of various mid- to large-scale equipment.

T5CC1 comes in a 100-pin flat package.

Listed below are the features.

- (1) High-speed 16-bit CPU (900/L1 CPU)
 - Instruction mnemonics are upward-compatible with TLCS-90/900
 - General-purpose registers and register banks
 - 16 Mbytes of linear address space
 - 16-bit multiplication and division instructions; bit transfer and arithmetic instructions
 - Micro DMA: 4-channels (593 ns/2 bytes at 27 MHz)
- (2) Minimum instruction execution time: 148 ns (at 27 MHz)
- (3) Built-in RAM: 16 Kbytes
 Built-in ROM: 256 Kbytes Flash memory
 4 Kbytes mask ROM (used for booting)

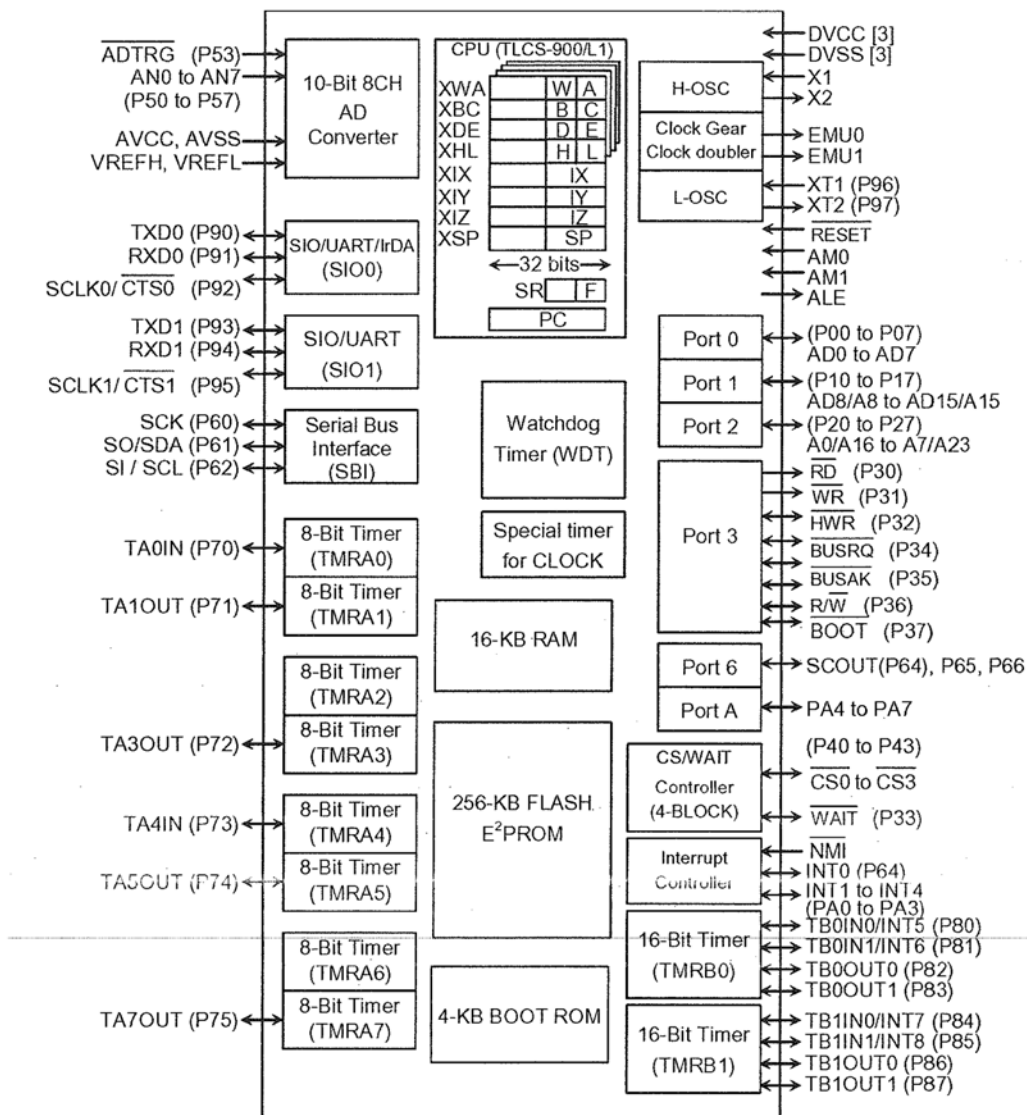

TOSHIBA

T5CC1

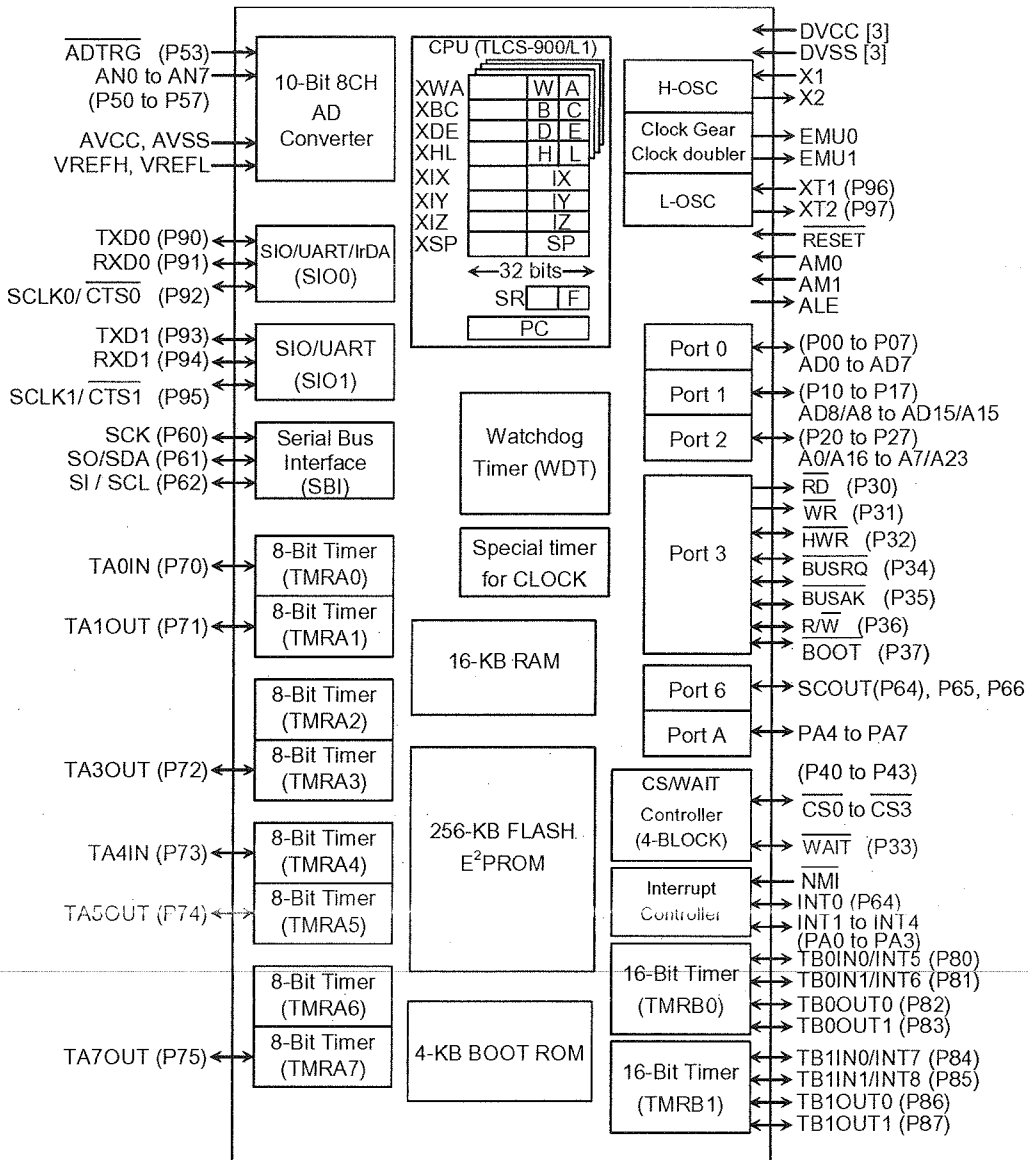

(): Initial function after reset

Figure 1.1 T5CC1 Block Diagram

2. Pin Assignment and Pin Functions

The assignment of input/output pins for the T5CC1, their names and functions are as follows:

2.1 Pin Assignment Diagram

Figure 2.1.1 shows the pin assignment of the T5CC1.

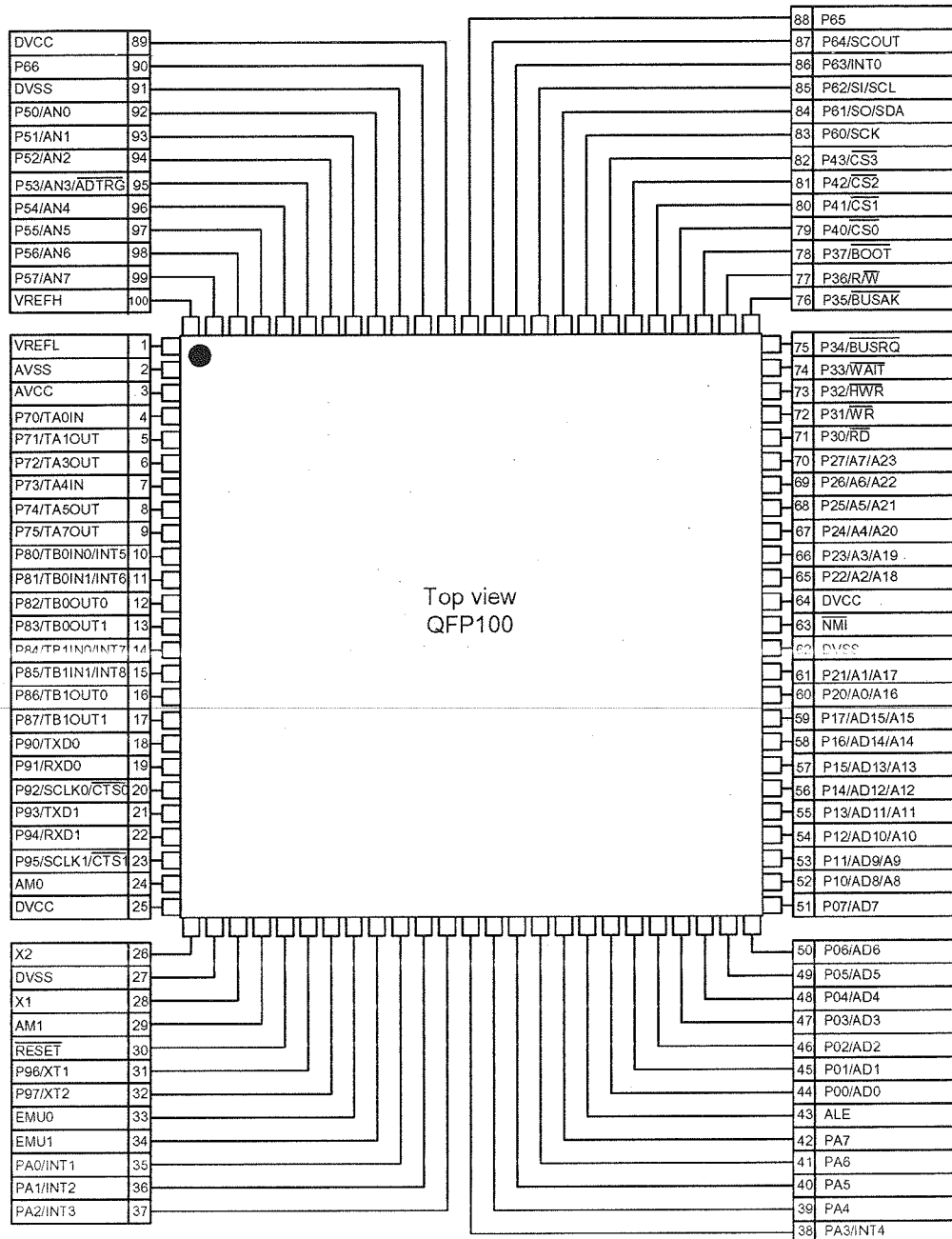

Figure 2.1.1 Pin assignment diagram (100-pin LQFP)

TOSHIBA

T5CC1

2.2 Pin Names and Functions

The names of the input/output pins and their functions are described below.

Table 2.2.1 Pin names and functions.

Table 2.2.1 Pin names and functions (1/3)

Pin Name	Number of Pins	I/O	Functions
P00~P07 AD0~AD7	8	I/O I/O	Port 0: I/O port that allows I/O to be selected at the bit level Address and data (lower): Bits 0 to 7 of address and data bus
P10~P17 AD8~AD15 A8~A15	8	I/O I/O Output	Port 1: I/O port that allows I/O to be selected at the bit level Address and data (upper): Bits 8 to 15 for address and data bus Address: Bits 8 to 15 of address bus
P20~P27 A0~A7 A16~A23	8	I/O Output Output	Port 2: I/O port that allows I/O to be selected at the bit level Address: Bits 0 to 7 of address bus Address: Bits 16 to 23 of address bus
P30 \overline{RD}	1	Output Output	Port 30: Output port Read: Strobe signal for reading external memory This port output RD signal also case of reading internal-area by setting P3 <P30> = 0 and P3FC <P30F> = 1.
P31 \overline{WR}	1	Output Output	Port 31: Output port Write: Strobe signal for writing data to pins AD0 to AD7
P32 \overline{HWR}	1	I/O Output	Port 32: I/O port (with pull-up resistor) High Write: Strobe signal for writing data to pins AD8 to AD15
P33 \overline{WAIT}	1	I/O Input	Port 33: I/O port (with pull-up resistor) Wait: Pin used to request CPU bus wait ((1+N) WAIT mode)
P34 BUSRQ	1	I/O Input	Port 34: I/O port (with pull-up resistor) Bus Request: Signal used to request Bus Release
P35 \overline{BUSAK}	1	I/O Output	Port 35: I/O port (with pull-up resistor) Bus Acknowledge: Signal used to acknowledge Bus Release
P36 R/ \overline{W}	1	I/O Output	Port 36: I/O port (with pull-up resistor) Read/Write: 1 represents Read or Dummy cycle; 0 represents Write cycle.
P37 \overline{BOOT}	1	I/O Input	Port 36: I/O port (with pull-up resistor) This pin sets single boot mode. When released reset, Single boot mode is started at P37 = Low level.
P40 $\overline{CS0}$	1	I/O Output	Port 40: I/O port (with pull-up resistor) Chip Select 0: Outputs 0 when address is within specified address area
P41 $\overline{CS1}$	1	I/O Output	Port 41: I/O port (with pull-up resistor) Chip Select 1: Outputs 0 if address is within specified address area
P42 $\overline{CS2}$	1	I/O Output	Port 42: I/O port (with pull-up resistor) Chip Select 2: Outputs 0 if address is within specified address area
P43 $\overline{CS3}$	1	I/O Output	Port 43: I/O port (with pull-up resistor) Chip Select 3: Outputs 0 if address is within specified address area
P50~P57 AN0~AN7 \overline{ADTRG}	8	Input Input Input	Port 5: Pin used to input port Analog input: Pin used to input to AD converter AD Trigger: Signal used to request start of AD converter (Shared with 53 pin)

TOSHIBA

T5CC1

Table 2.2.1 Pin names and functions (2/3)

Pin Name	Number of Pins	I/O	Functions
P60 SCK	1	I/O I/O	Port 60: I/O port Serial bus interface clock in SIO Mode
P61 SO SDA	1	I/O Output I/O	Port 61: I/O port Serial bus interface send data at SIO mode Serial bus interface send/recv data at I ² C bus mode Open-drain output mode by programmable
P62 SI SCL	1	I/O Input I/O	Port 62: I/O port Serial bus interface receive data at SIO mode Serial bus interface clock I/O data at I ² C bus mode Open-drain output mode by programmable
P63 INT0	1	I/O Input	Port 63: I/O port Interrupt Request Pin 0: Interrupt request pin with programmable level / rising edge / falling edge
P64 SCOUT	1	I/O Output	Port 64: I/O port System Clock Output: Outputs f _{PPH} or fs clock.
P65	1	I/O	Port 65 I/O port
P66	1	I/O	Port 66 I/O port
P70 TA0IN	1	I/O Input	Port 70 I/O port 8-bit timer 0 input: Timer 0 input
P71 TA1OUT	1	I/O Output	Port 71 I/O port 8-bit timer 1 output: Timer 0 or Timer 1 output
P72 TA3OUT	1	I/O Output	Port 72 I/O port 8-bit 8-bit timer 3 output: Timer 2 or Timer 3 output
P73 TA4IN	1	I/O Input	Port 73: I/O port 8-bit timer 4 input: Timer 4 input
P74 TA5OUT	1	I/O Output	Port 74: I/O port 8-bit timer 5 output: Timer 4 or Timer 5 output
P75 TA7OUT	1	I/O Output	Port 75: I/O port 8-bit timer 7 output: Timer 6 or Timer 7 output
P80 TB0IN0 INT5	1	I/O Input Input	Port 80: I/O port 16-bit timer 0 input 0: 16-bit Timer 0 count / capture trigger input Interrupt Request Pin 5: Interrupt request pin with programmable rising edge / falling edge.
P81 TB0IN1 INT6	1	I/O Input Input	Port 81: I/O port 16-bit timer 0 input 1: 16-bit Timer 0 count / capture trigger input Interrupt Request Pin 6: Interrupt request on rising edge
P82 TB0OUT0	1	I/O Output	Port 82: I/O port 16-bit timer 0 output 0: 16-bit Timer 0 output
P83 TB0OUT1	1	I/O Output	Port 83: I/O port 16-bit timer 0 output 1: 16-bit Timer 0 output
P84 TB1IN0 INT7	1	I/O Input Input	Port 84: I/O port 16-bit timer 1 input 0: 16-bit Timer 1 count / capture trigger input Interrupt Request Pin 7: Interrupt request pin with programmable rising edge / falling edge.
P85 TB1IN1 INT8	1	I/O Input Input	Port 85: I/O port 16-bit timer 1 input 1: 16-bit Timer 1 count / capture trigger input Interrupt Request Pin 8: Interrupt request on rising edge
P86 TB1OUT0	1	I/O Output	Port 86: I/O port 16-bit timer 1 output 0: 16-bit Timer 1 output 16-bit
P87 TB1OUT1	1	I/O Output	Port 87: I/O port 16-bit timer 1 output 1: 16-bit Timer 1 output 16-bit

TOSHIBA

T5CC1

Table 2.2.1 Pin names and functions (3/3)

Pin Name	Number of Pins	I/O	Functions
P90 TXD0	1	I/O Output	Port 90: I/O port Serial Send Data 0 (programmable open-drain)
P91 RXD0	1	I/O Input	Port 91: I/O port Serial Receive Data 0
P92 SCLK0 CTS0	1	I/O I/O Input	Port 92: I/O port Serial Clock I/O 0 Serial Data Send Enable 0 (Clear to Send)
P93 TXD1	1	I/O Output	Port 93: I/O port Serial Send Data 1 (programmable open-drain)
P94 RXD1	1	I/O Input	Port 94: I/O port (with pull-up resistor) Serial Receive Data 1
P95 SCLK1 CTS1	1	I/O I/O Input	Port 95: I/O port (with pull-up resistor) Serial Clock I/O 1 Serial Data Send Enable 1 (Clear to Send)
P96 XT1	1	I/O Input	Port 96: I/O port (open-drain output) Low-frequency oscillator connection pin
P97 XT2	1	I/O Output	Port 97: I/O port (open-drain output) Low-frequency oscillator connection pin
PA0~PA3 INT1~INT4	4	I/O Input	Ports A0 to A3: I/O ports Interrupt Request Pins 1 to 4: Interrupt request pins with programmable rising edge / falling edge.
PA4~PA7	4	I/O	Ports A4 to A7: I/O ports
ALE	1	Output	Address Latch Enable Can be disabled to reduce noise.
NMI	1	Input	Non-Maskable Interrupt Request Pin: Interrupt request pin with programmable falling edge or both edge.
AM0~1	2	Input	Operation mode: Fixed to AM1 = 1, AM0 = 1
EMU0	1	Output	Open pin
EMU1	1	Output	Open pin
RESET	1	Input	Reset: initializes T5CC1. (With pull-up resistor)
VREFH	1	Input	Pin for reference voltage input to AD converter (H)
VREFL	1	Input	Pin for reference voltage input to AD converter (L)
AVCC	1		Power supply pin for AD converter
AVSS	1		GND pin for AD converter (0 V)
X1/X2	2	I/O	High-frequency oscillator connection pins
DVCC	3		Power supply pins (All DVCC pins should be connected with the power supply pin.)
DVSS	3		GND pins (0 V) (All DVSS pins should be connected with the power supply pin.)

Note: An external DMA controller cannot access the device's built-in memory or built-in I/O devices using the $\overline{\text{BUSRQ}}$ and $\overline{\text{BUSAk}}$ signal.



NJM2595

5-INPUT 3-OUTPUT VIDEO SWITCH

■ GENERAL DESCRIPTION

The **NJM2595** is a 5-input 3-output video switch. Its switches select one from five signals received from VTR,TV,DVD, TV-GAME and others.

The NJM2595 is designed for audio items, such as AV amplifier and others.

■ PACKAGE OUTLINE

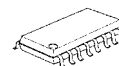
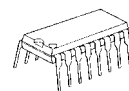

NJM2595D NJM2595M

■ FEATURES

- 5-input 3-output
- Operating Voltage ± 4.0 to $\pm 6.5V$
- Operating current $\pm 15mA$ typ. at $V_{CC}=\pm 5V$
- Crosstalk $-65dB$ typ.
- Internal 6dB Amplifier
- Internal 75Ω Driver
- Bipolar Technology
- Package Outline DIP16,DMP16

■ PIN CONFIGURATION and BLOCK DIAGRAM

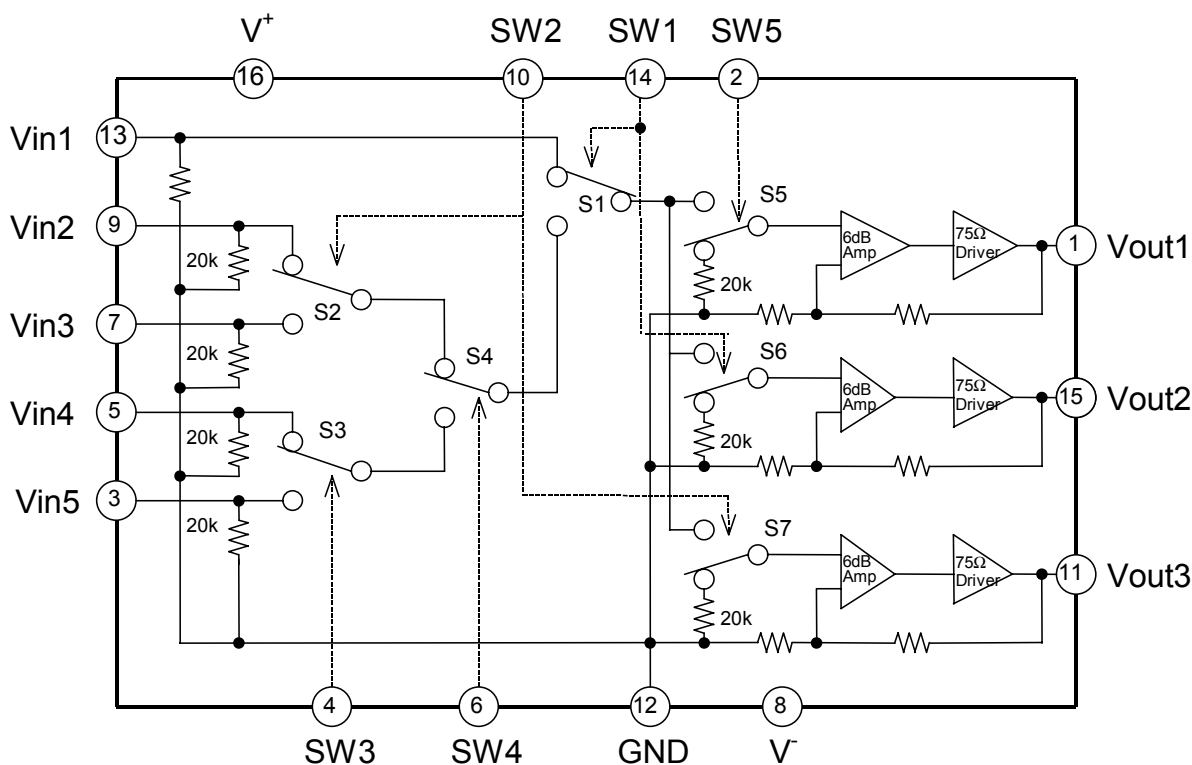

NJM2595

■ EQUIVALENT CIRCUIT

PIN No.	PIN NAME	INSIDE EQUIVALENT CIRCUIT	VOLTAGE
16	V ⁺		5V
8	V ⁻		-5V
12	GND		-
13 9 7 5 3	Vin1 Vin2 Vin3 Vin4 Vin5		0V
1 15 11	Vout1 Vout2 Vout3		0V
4 6 2	SW3 SW4 SW5		-

NJM2595

EQUIVALENT CIRCUIT

PIN No.	PIN NAME	INSIDE EQUIVALENT CIRCUIT	VOLTAGE
14 10	SW1 SW2		-

TEST CIRCUIT

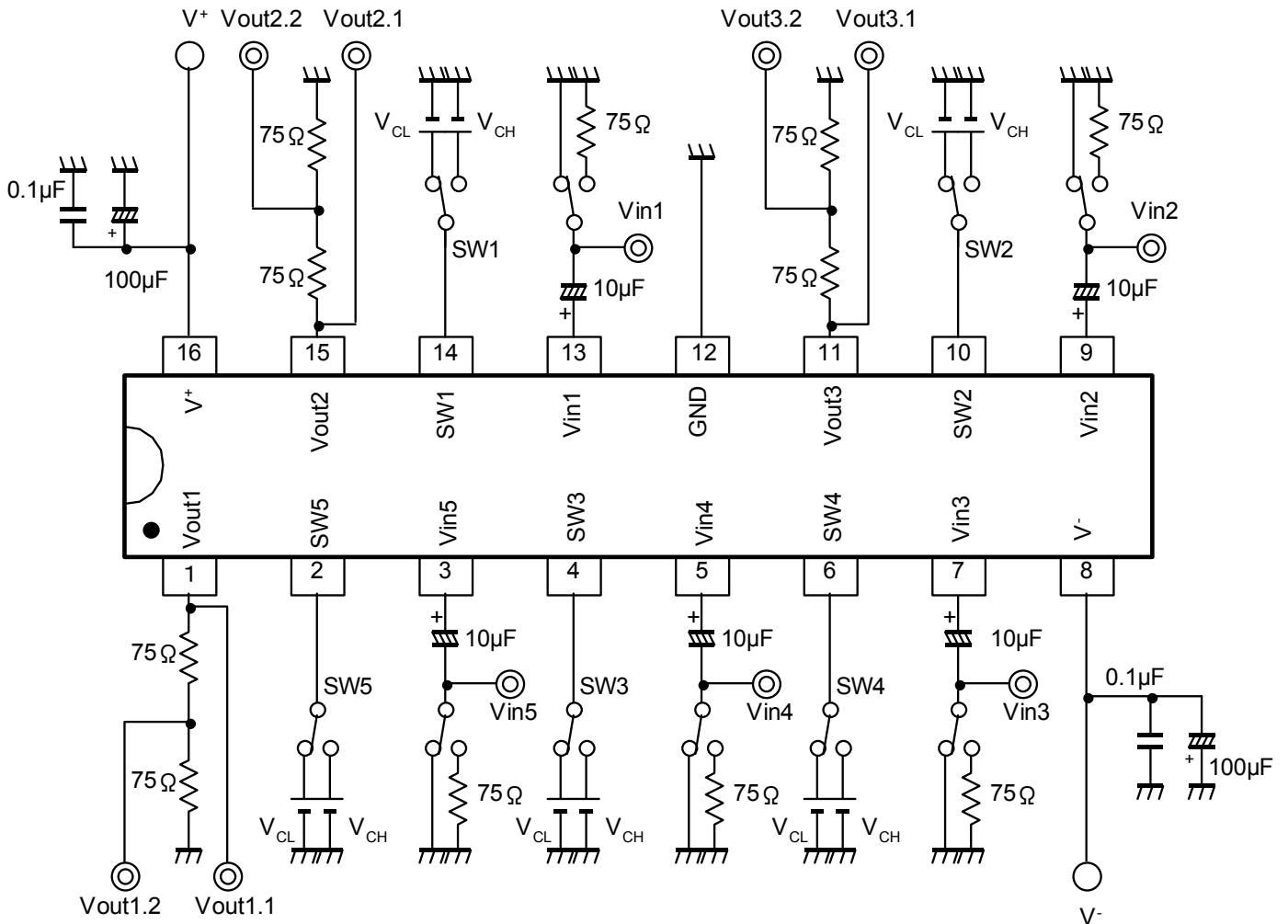

NJM2068M (OP - AMP)



NJM2068

LOW-NOISE DUAL OPERATIONAL AMPLIFIER

■ **GENERAL DESCRIPTION**

The NJM2068 is a high performance, low noise dual operational amplifier. This amplifier features harmonic popular pin-out, superior noise performance, and superior total harmonic distortion. This amplifier also features guaranteed noise performance with substantially higher gain-bandwidth product and slew rate which far exceeds that of the 4558 type amplifier. The specially designed low noise input transistors allow the NJM2068 to be used in very low noise signal processing applications such as audio preamplifiers and servo error amplifier.

■ **PACKAGE OUTLINE**

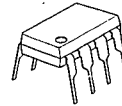

NJM2068D



NJM2068M



NJM2068V

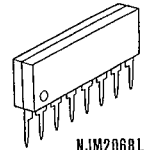

NJM2068L

■ **FEATURES**

- Operating Voltage $(\pm 4V \sim \pm 18V)$
- Low Total Harmonic Distortion $(0.001\% \text{ typ.})$
- Low Noise Voltage $(\text{FLAT+JISA}, 0.56 \mu V \text{ typ.})$
- High Slew Rate $(6V/\mu s \text{ typ.})$
- Unity Gain Bandwidth $(27\text{MHz @ } f=10\text{kHz})$
- Package Outline DIP8, DMP8, SIP8, SSOP8
- Bipolar Technology

■ **PIN CONFIGURATION**

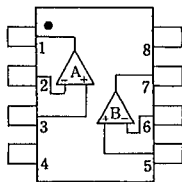

NJM2068D
NJM2068M
NJM2068V

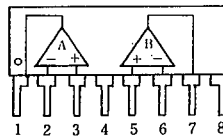

NJM2068L

PIN FUNCTION

1. A OUTPUT
2. A-INPUT
3. A+INPUT
4. V-
5. B+INPUT
6. B-INPUT
7. B OUTPUT
8. V+

■ **EQUIVALENT CIRCUIT (1/2 Shown)**

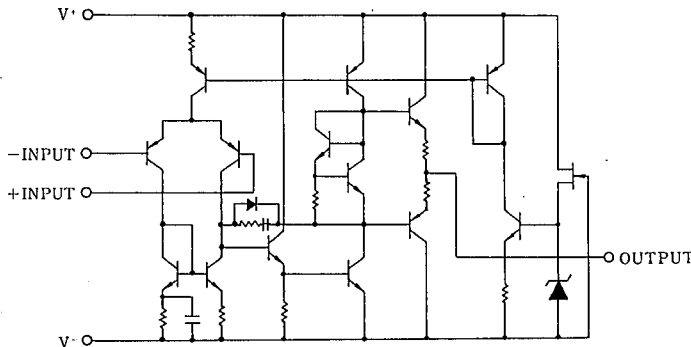



NJM4556A

DUAL HIGH CURRENT OPERATIONAL AMPLIFIER

■ GENERAL DESCRIPTION

The NJM4556A integrated circuit is a high-gain, high output current dual operational amplifier capable of driving $\pm 70\text{mA}$ into $150\ \Omega$ loads ($\pm 10.5\text{V}$ output voltage), and operating low supply voltage ($V^+/V^- = \pm 2\text{V} \sim$).

The NJM4556A combines many of the features of the popular NJM4558 as well as having the capability of driving $150\ \Omega$ loads. In addition, the wide band-width, low noise, high slew rate and low distortion of the NJM4556A make it ideal for many audio, telecommunications and instrumentation applications.

■ FEATURES

- Operating Voltage ($\pm 2\text{V} \sim \pm 18\text{V}$)
- High Output Current ($I_o = 70\text{mA}$)
- Slew Rate ($3\text{V}/\mu\text{s}$ typ.)
- Gain Band Width Product (8MHz typ.)
- Package Outline DIP8, DMP8, SIP8, SSOP8
- Bipolar Technology

■ PACKAGE OUTLINE

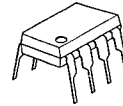

NJM4556AD



NJM4556AM

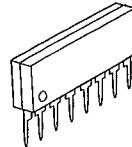

NJM4556AL



NJM4556AV

■ PIN CONFIGURATION

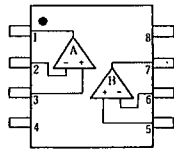

NJM4556AD.
NJM4556AM
NJM4556AV

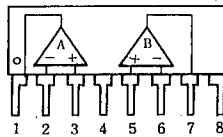

NJM4556AL

PIN FUNCTION

1. A OUTPUT
2. A-INPUT
3. A+INPUT
4. V-
5. B+INPUT
6. B-INPUT
7. B OUTPUT
8. V+

■ EQUIVALENT CIRCUIT (1/2 Shown)

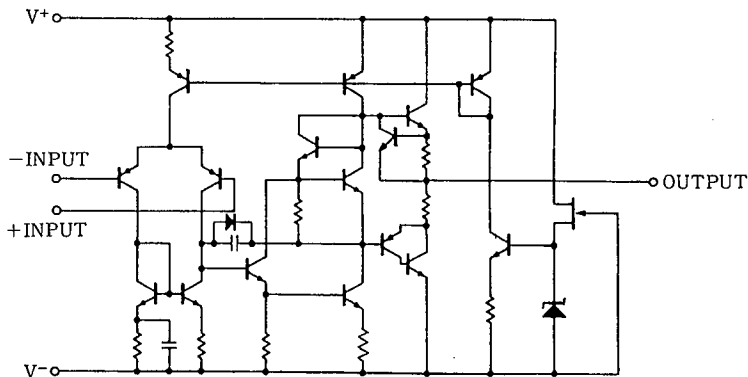

LOW VOLTAGE DETECTOR

R×5VT SERIES

R×5VT

PIN CONFIGURATION

• TO-92

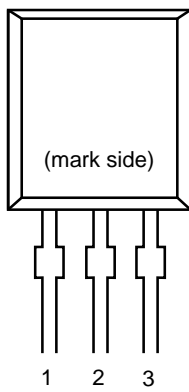

• SOT-89

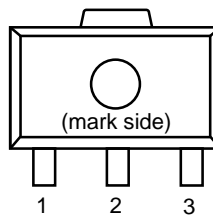

• SOT-23-5

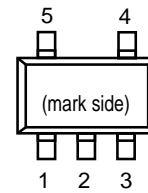

PIN DESCRIPTION

• TO-92

Pin No.	Symbol
1	OUT
2	V _{DD}
3	GND

• SOT-89

Pin No.	Symbol
1	OUT
2	V _{DD}
3	GND

• SOT-23-5

Pin No.	Symbol
1	OUT
2	V _{DD}
3	GND
4	NC
5	NC



74ACT04

HEX INVERTER

- HIGH SPEED: $t_{PD} = 5.0ns$ (TYP.) at $V_{CC} = 5V$
- LOW POWER DISSIPATION:
 $I_{CC} = 2\mu A$ (MAX.) at $T_A=25^\circ C$
- COMPATIBLE WITH TTL OUTPUTS
 $V_{IH} = 2V$ (MIN.), $V_{IL} = 0.8V$ (MAX.)
- 50Ω TRANSMISSION LINE DRIVING CAPABILITY
- SYMMETRICAL OUTPUT IMPEDANCE:
 $|I_{OH}| = I_{OL} = 24mA$ (MIN)
- BALANCED PROPAGATION DELAYS:
 $t_{PLH} \approx t_{PHL}$
- OPERATING VOLTAGE RANGE:
 V_{CC} (OPR) = 4.5V to 5.5V
- PIN AND FUNCTION COMPATIBLE WITH 74 SERIES 04
- IMPROVED LATCH-UP IMMUNITY

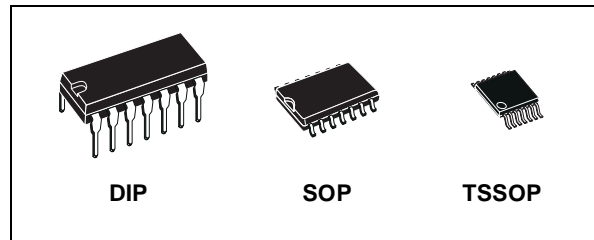

ORDER CODES

PACKAGE	TUBE	T & R
DIP	74ACT04B	
SOP	74ACT04M	74ACT04MTR
TSSOP		74ACT04TTR

DESCRIPTION

The 74ACT04 is an advanced high-speed CMOS HEX INVERTER fabricated with sub-micron silicon gate and double-layer metal wiring C²MOS technology.

The internal circuit is composed of 3 stages including buffer output, which enables high noise immunity and stable output.

The device is designed to interface directly High Speed CMOS systems with TTL, NMOS and CMOS output voltage levels.

All inputs and outputs are equipped with protection circuits against static discharge, giving them 2KV ESD immunity and transient excess voltage.

PIN CONNECTION AND IEC LOGIC SYMBOLS

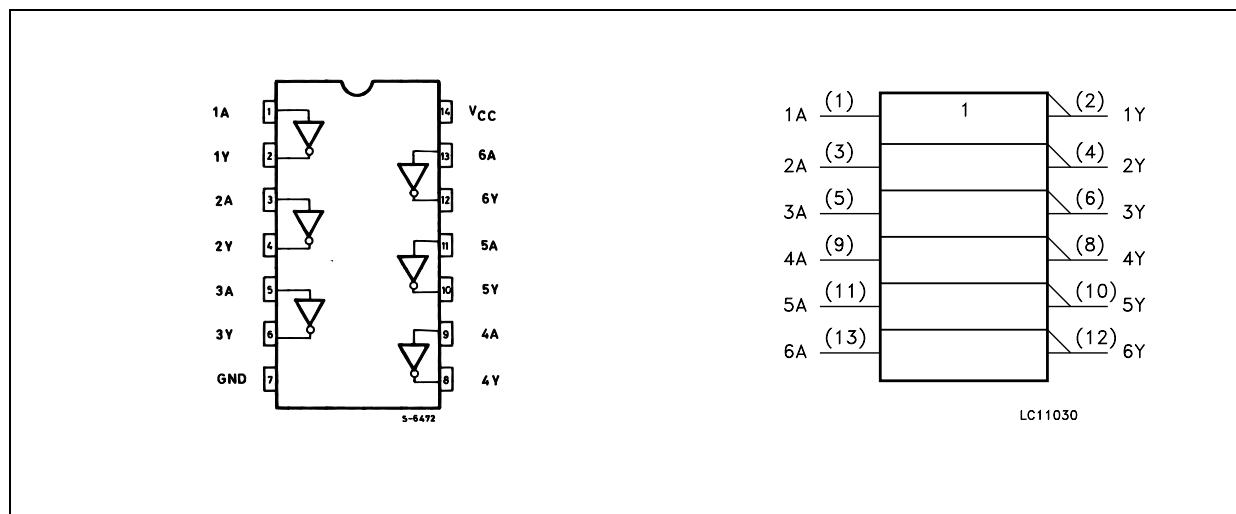

74ACT04

INPUT AND OUTPUT EQUIVALENT CIRCUIT

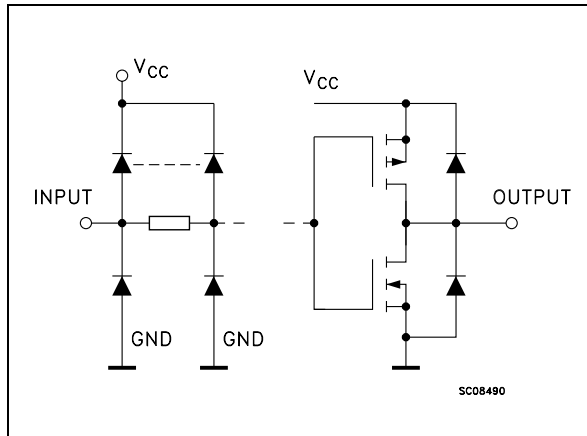

PIN DESCRIPTION

PIN No	SYMBOL	NAME AND FUNCTION
1, 3, 5, 9, 11, 13	1A to 6A	Data Inputs
2, 4, 6, 8, 10, 12	1Y to 6Y	Data Outputs
7	GND	Ground (0V)
14	V _{CC}	Positive Supply Voltage

TRUTH TABLE

A	Y
L	H
H	L

ABSOLUTE MAXIMUM RATINGS

Symbol	Parameter	Value	Unit
V _{CC}	Supply Voltage	-0.5 to +7	V
V _I	DC Input Voltage	-0.5 to V _{CC} + 0.5	V
V _O	DC Output Voltage	-0.5 to V _{CC} + 0.5	V
I _{IK}	DC Input Diode Current	± 20	mA
I _{OK}	DC Output Diode Current	± 20	mA
I _O	DC Output Current	± 50	mA
I _{CC} or I _{GND}	DC V _{CC} or Ground Current	± 200	mA
T _{stg}	Storage Temperature	-65 to +150	°C
T _L	Lead Temperature (10 sec)	300	°C

Absolute Maximum Ratings are those values beyond which damage to the device may occur. Functional operation under these conditions is not implied.

RECOMMENDED OPERATING CONDITIONS

Symbol	Parameter	Value	Unit
V _{CC}	Supply Voltage	4.5 to 5.5	V
V _I	Input Voltage	0 to V _{CC}	V
V _O	Output Voltage	0 to V _{CC}	V
T _{op}	Operating Temperature	-55 to 125	°C
dt/dv	Input Rise and Fall Time V _{CC} = 4.5 to 5.5V (note 1)	8	ns/V

1) V_{IN} from 0.8V to 2.0V



**SEMICONDUCTOR
TECHNICAL DATA**

**KIA278R05PI~KIA278R15PI
BIPOLAR LINEAR INTEGRATED CIRCUIT**

**4 TERMINAL 2A OUTPUT LOW DROP
VOLTAGE REGULATOR**

The KIA278R × × Series are Low Drop Voltage Regulator suitable for various electronic equipments. It provides constant voltage power source with TO-220 4 terminal lead full molded PKG. The Regulator has multi function such as over current protection, overheat protection and ON/OFF control.

FEATURES

- 2.0A Output Low Drop Voltage Regulator.
- Built in ON/OFF Control Terminal.
- Built in Over Current Protection, Over Heat Protection Function.

LINE UP

ITEM	OUTPUT VOLTAGE (Typ.)	UNIT
KIA278R05PI	5	V
KIA278R06PI	6	
KIA278R08PI	8	
KIA278R09PI	9	
KIA278R10PI	10	
* KIA278R15PI	15	

* Note) * : Under Development.

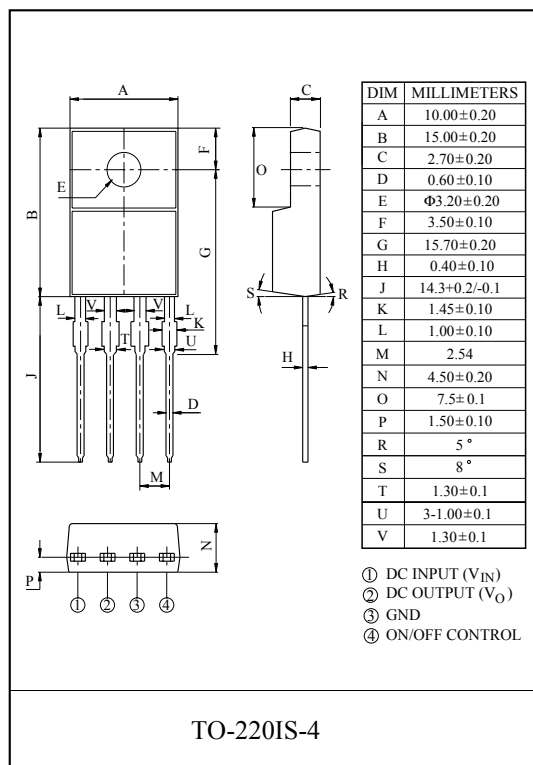

MAXIMUM RATING (Ta=25°C)

CHARACTERISTIC	SYMBOL	RATING	UNIT	Remark
Input Voltage	V _{IN}	35	V	-
ON/OFF Control Voltage	V _C	35	V	-
Output Current	I _O	2	A	-
Power Dissipation 1	P _{d1}	1.5	W	No heatsink
Power Dissipation 2	P _{d2}	15	W	with heatsink
Junction Temperature	T _j	125	°C	-
Operating Temperature	T _{opr}	-20 ~ 80	°C	-
Storage Temperature	T _{stg}	-30 ~ 125	°C	-
Soldering Temperature (10sec)	T _{sol}	260	°C	-



SEMICONDUCTOR TECHNICAL DATA

KIA1117S/F00~ KIA1117S/F50 BIPOLAR LINEAR INTEGRATED CIRCUIT

LOW DROP FIXED AND ADJUSTABLE POSITIVE VOLTAGE REGULATOR

The KIA1117S/F × × is a Low Drop Voltage Regulator able to provide up to 1A of output current, available even in adjustable version (Vref=1.25V)

FEATURES

- Low Dropout Voltage : 1.1V/Typ. (Iout=1.0A)
- Very Low Quiescent Current : 4.2mA/Typ.
- Output Current up to 1A
- Fixed Output Voltage of 1.5V, 1.8V, 2.5V, 2.85V, 3.3V, 5.0V
- Adjustable Version Availability : Vref=1.25V
- Internal Current and Thermal Limit
- Only 10µF for stability
- Available in ±2% (at 25 °C) and 4% in full Temperature range
- High Ripple Rejection : 80dB/Typ
- Temperature Range : 0 °C ~ 125 °C

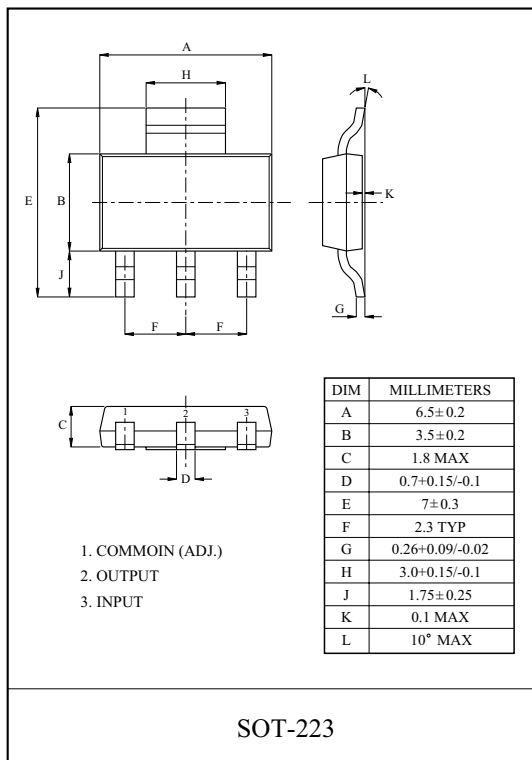

LINE UP

ITEM	OUTPUT VOLTAGE (V)	PACKAGE
KIA1117S/F00	Adjustable (1.25~10V)	S : SOT-223 F : DPAK
KIA1117S/F15	1.5	
KIA1117S/F18	1.8	
KIA1117S/F25	2.5	
KIA1117S/F28	2.85	
KIA1117S/F33	3.3	
KIA1117S/F50	5.0	

MAXIMUM RATINGS (Ta=25 °C)





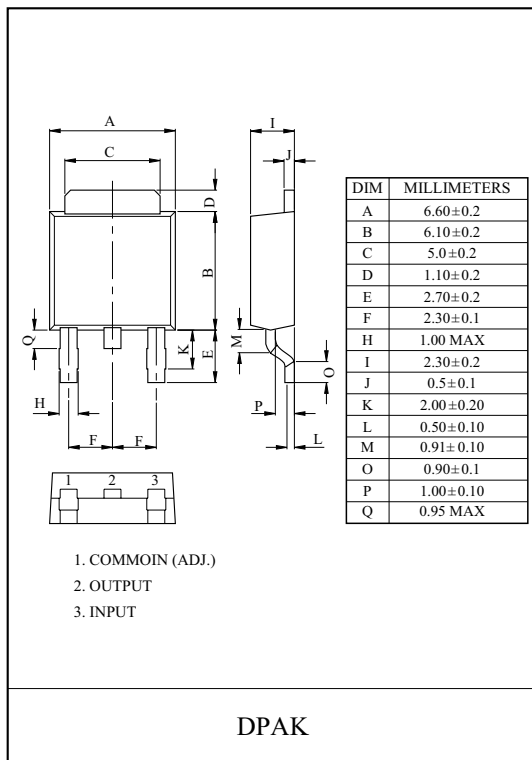

CHARACTERISTIC	SYMBOL	RATING	UNIT
Input Voltage	V _{IN}	10	V
Output Current	S/F I _{OUT}	1.0	A
Power Dissipation 1 (No heatsink)	S (Note)	1.0	W
	F	1.3	
Power Dissipation 2 (Without heatsink)	S	8.3	W
	F	13	
Operating Temperature	T _{opr}	0 ~ 125	°C
Storage Temperature	T _{stg}	-55 ~ 150	°C

Note) Package Mounted on FR-4 PCB 36 × 18 × 1.5 mm.

: mounting pad for the GND Lead min. 6cm²

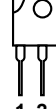

TRANSISTOR, REGULATOR IC BLOCK DIAGRAM

<p>TO-92M</p>  <p>1. Emitter 2. Collector 3. Base</p> <p>123</p> <p>KTC2874B KSC2785Y KRA107M KRC107M KRA104MT KRC104M KTA1267</p>	<p>TO-92</p>  <p>1. Emitter 2. Collector 3. Base</p> <p>123</p> <p>KTD1302T KTA1268GR KTC3200GR KTC3198Y KTA1271Y KSA1175YT</p>	<p>TO-220</p>  <p>1. GND 2. INPUT 3. OUTPUT</p> <p>123</p> <p>MCNJM7905 MC7915C NJM7908 L7905 L7915</p>	<p>TO-92L</p>  <p>1. Emitter 2. Collector 3. Base</p> <p>123</p> <p>KTA1024Y KSC2316Y</p>
<p>TO-126</p>  <p>1. Emitter 2. Collector 3. Base</p> <p>123</p> <p>KTD600KG</p>	<p>TO-92</p>  <p>1. Emitter 2. Base 3. Collector</p> <p>123</p> <p>KSA733CYT</p>	<p>TO-220</p>  <p>1. INPUT 2. GND 3. OUTPUT</p> <p>123</p> <p>MC7815C MC7805C MC7809 L7805 NJM7824 L7815 L7812 L7808</p>	<p>TO-3P</p>  <p>1. Base 2. Collector 3. Emitter</p> <p>1 2 3</p> <p>2SB1560 2SC3423O 2SD2390 2SB1559 2SA1360 2SD2389 2SB1647 2SD2560</p>

**NJM2391DL1-25 NJM2391DL1-33
LOW DROPOUT VOLTAGE REGULATOR**

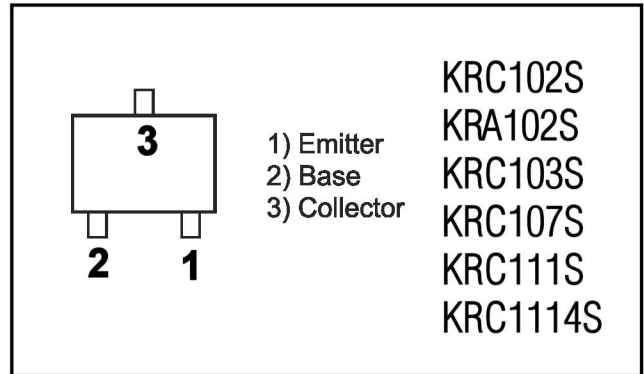
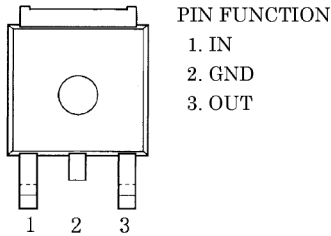

**N-CHANNEL MOS FET ARRAY
μPA672T**

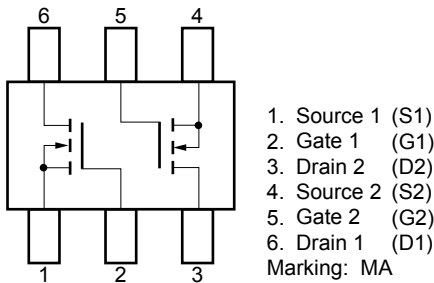

**PIN CONFIGURATION
SOT-23 Package
AD1580**

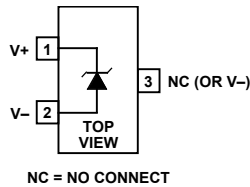

SOT-223 PKG (FRONT VIEW)

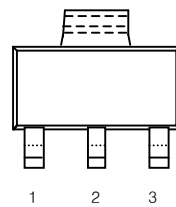

**LM1117
REGULATOR**

PIN FUNCTION
1. Adj/Gnd
2. Vout
3. Vin

TO-263 (D2 PKG, FRONT VIEW)

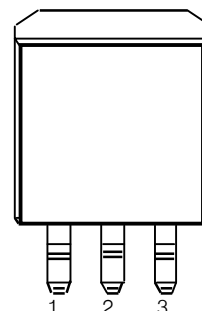

PIN FUNCTION
1. Adj/Gnd
2. Vout
3. Vin

KP1010 photocoupler

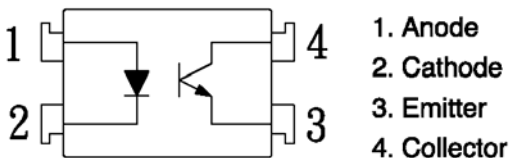

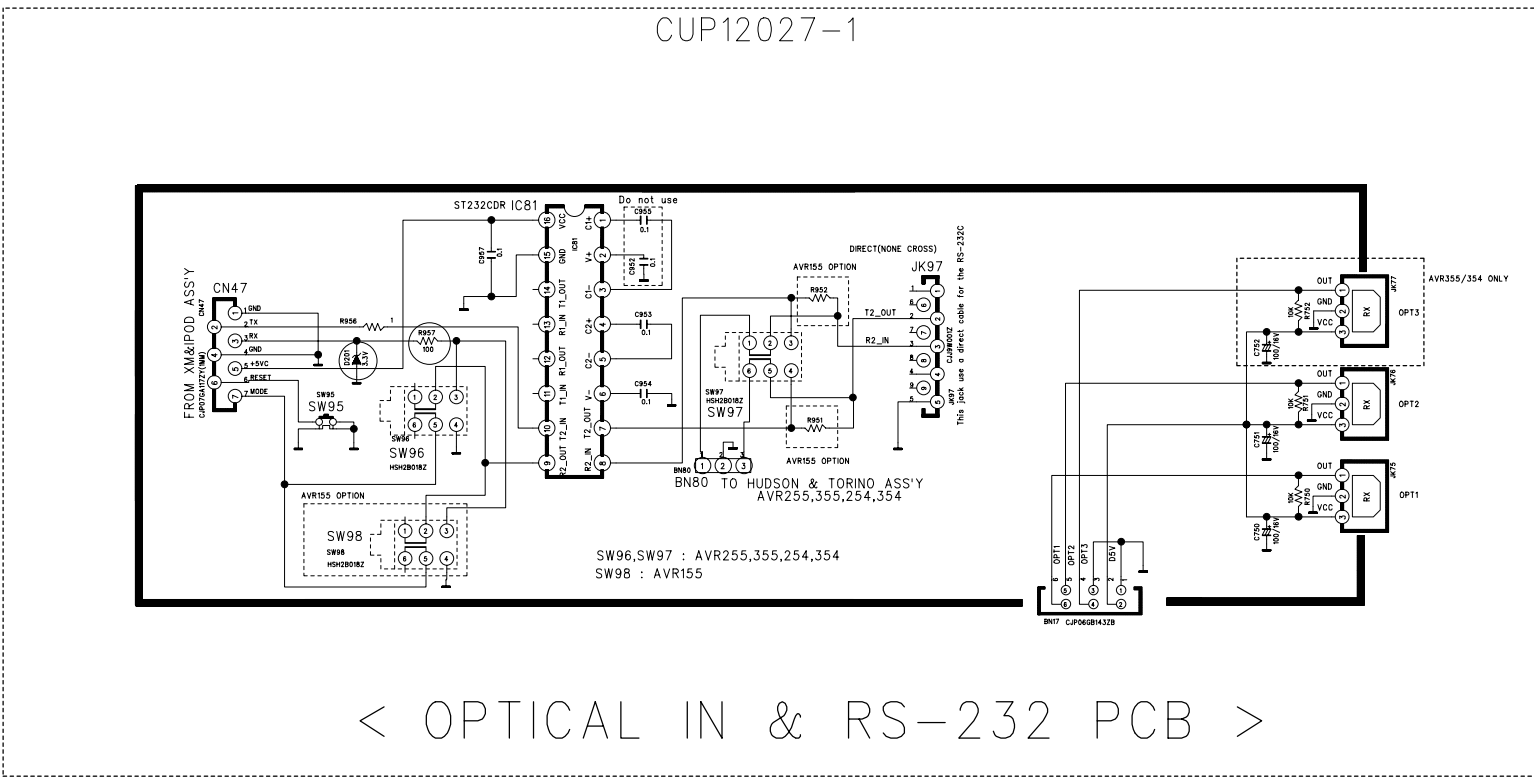

< OPTICAL IN & RS-232 PCB >

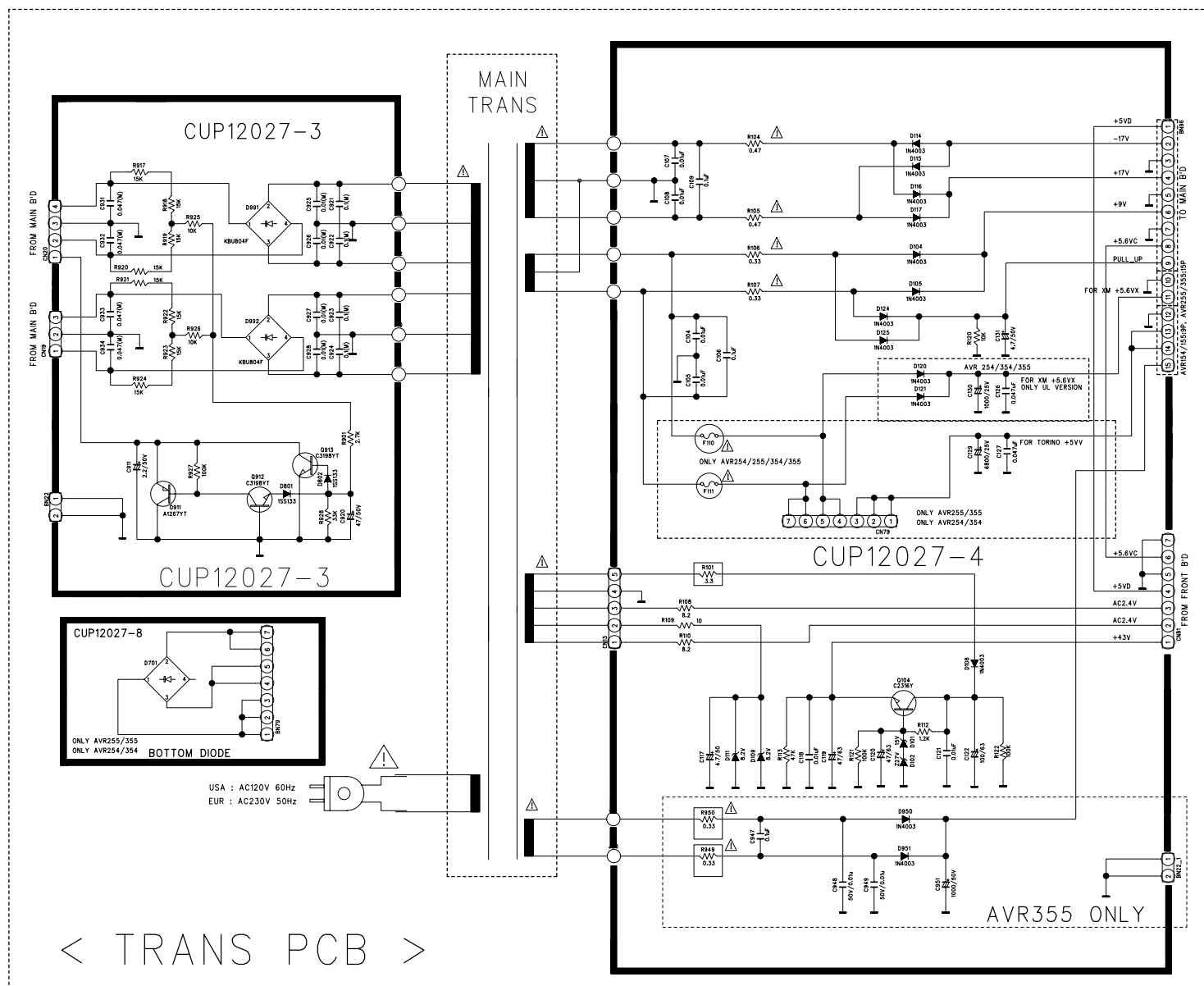
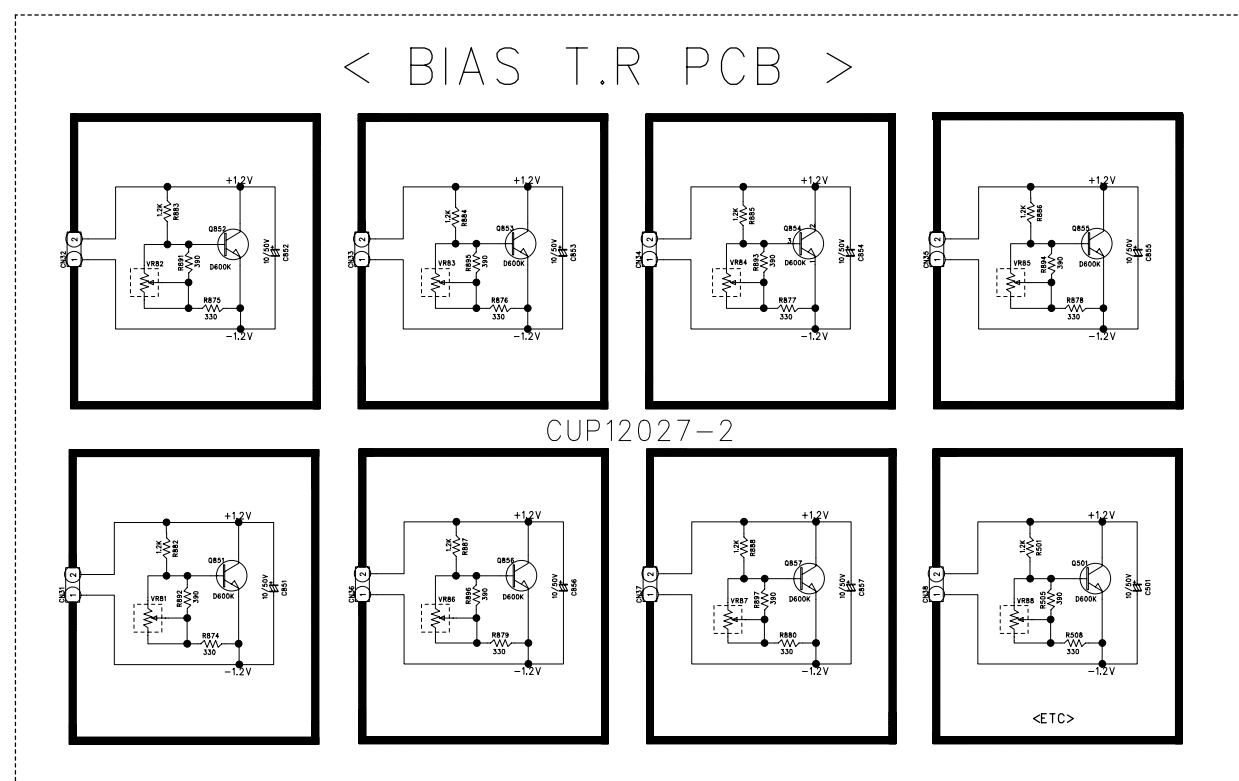

< TRANS PCB >

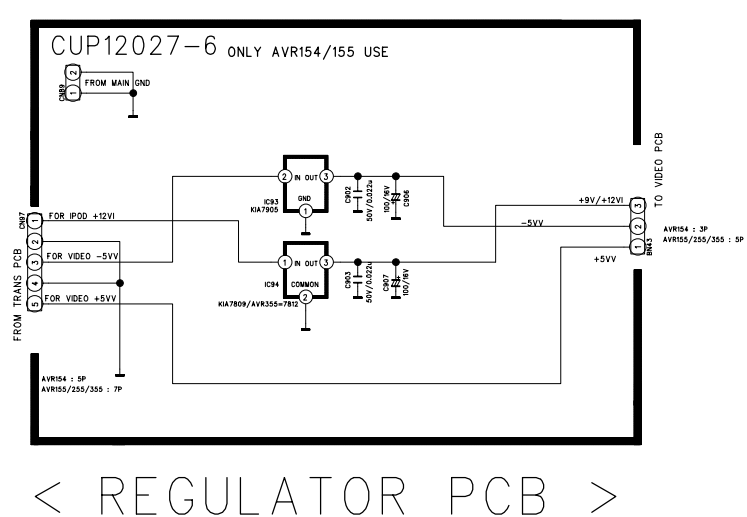
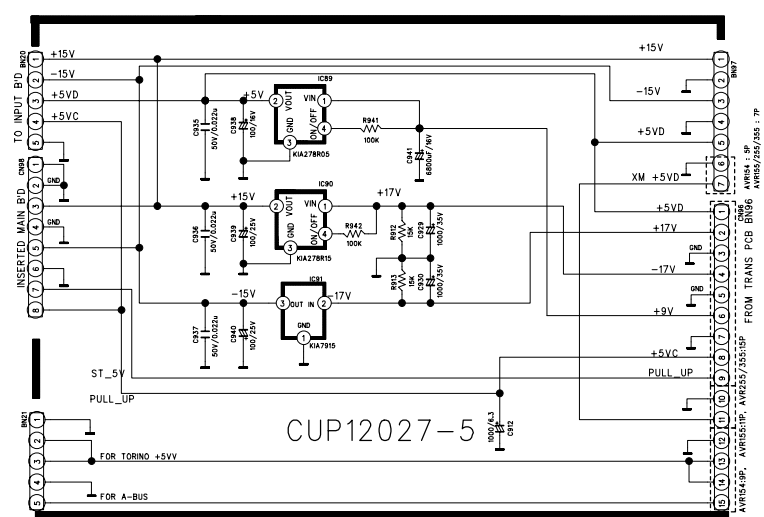

< REGULATOR PCB >

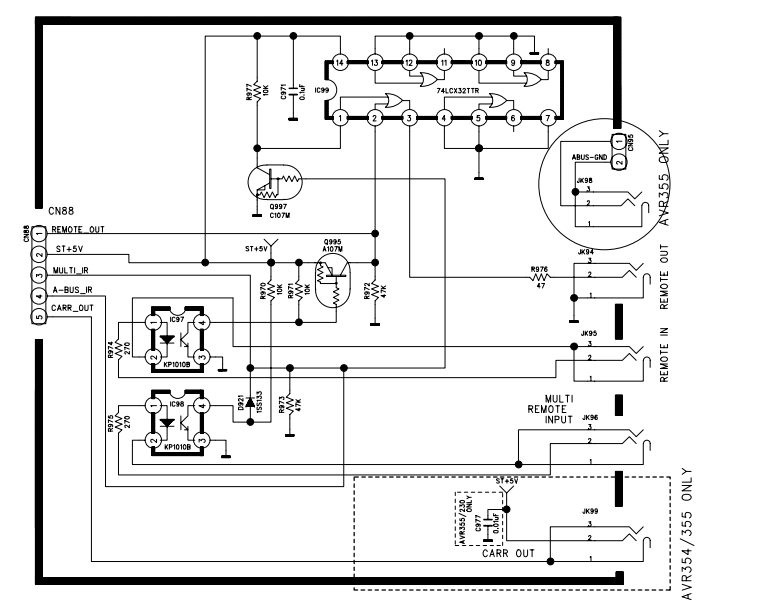

< REMOTE IN/OUT PCB >

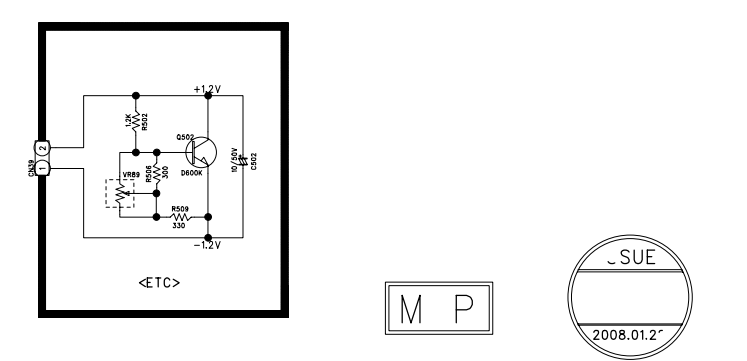

REVISION	2	4	6
1	3	5	7
SCHEMATIC DIAGRAM			
MODEL	AVR x54/x55		
DESIGN	CHECK	APPROVE	DRAWING NO
J.T.B	Y.Y.W	K.S.W	CUP12027Z
08.01.22			(POWER)

CUP12028Z

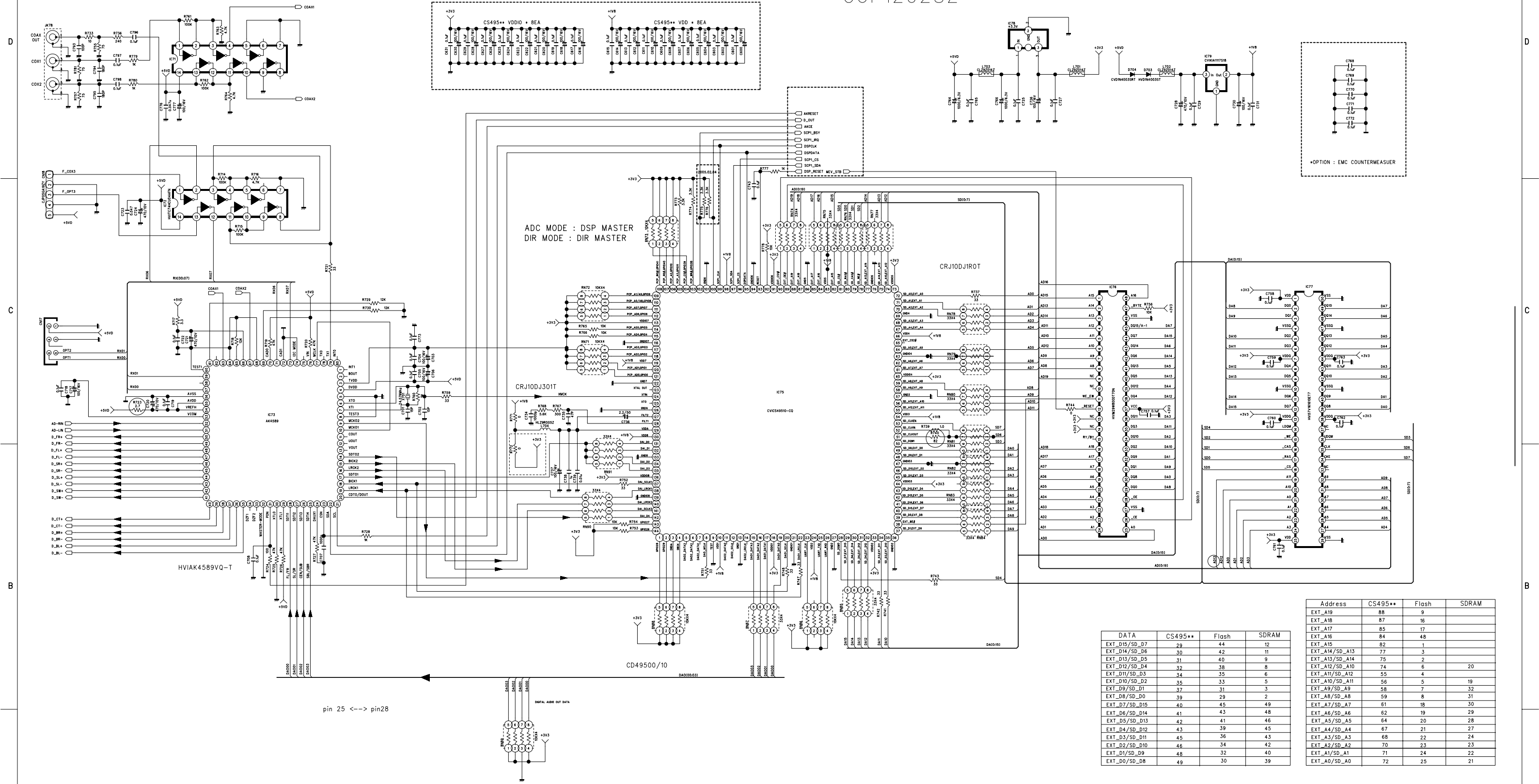

DATA	CS495**	Flash	SDRAM
EXT_D15/SD_D7	29	44	12
EXT_D14/SD_D6	30	42	11
EXT_D13/SD_D5	31	40	9
EXT_D12/SD_D4	34	38	6
EXT_D11/SD_D3	32	35	5
EXT_D10/SD_D2	35	33	5
EXT_D9/SD_D1	37	31	3
EXT_D8/SD_D0	39	29	2
EXT_D7/SD_D15	40	45	49
EXT_D6/SD_D14	41	43	48
EXT_D5/SD_D13	42	41	46
EXT_D4/SD_D12	43	39	45
EXT_D3/SD_D11	45	36	43
EXT_D2/SD_D10	46	34	42
EXT_D1/SD_D9	48	32	40
EXT_D0/SD_D8	49	30	39

Address	CS495**	Flash	SDRAM
EXT_A19	88	9	
EXT_A18	87	16	
EXT_A17	85	17	
EXT_A16	84	48	
EXT_A15	82	1	
EXT_A14/SD_A13	77	3	
EXT_A13/SD_A14	75	2	
EXT_A12/SD_A10	74	6	20
EXT_A11/SD_A12	55	4	
EXT_A10/SD_A11	56	5	19
EXT_A9/SD_A9	58	7	32
EXT_A8/SD_A8	59	8	31
EXT_A7/SD_A7	61	18	30
EXT_A6/SD_A6	62	19	29
EXT_A5/SD_A5	64	20	28
EXT_A4/SD_A4	67	21	27
EXT_A3/SD_A3	68	22	24
EXT_A2/SD_A2	70	23	23
EXT_A1/SD_A1	71	24	22
EXT_A0/SD_A0	72	25	21

REVISION	2	4	6
1	3	5	7
SCHEMATIC DIAGRAM			
MODEL	AVR154/155		
DESIGN	CHECK	APPROVE	DRAWING NO
C.B.LEE	W.Y.YANG	G.S.WEY	2028SCLZ
07.05.28			(DSP)

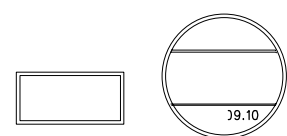

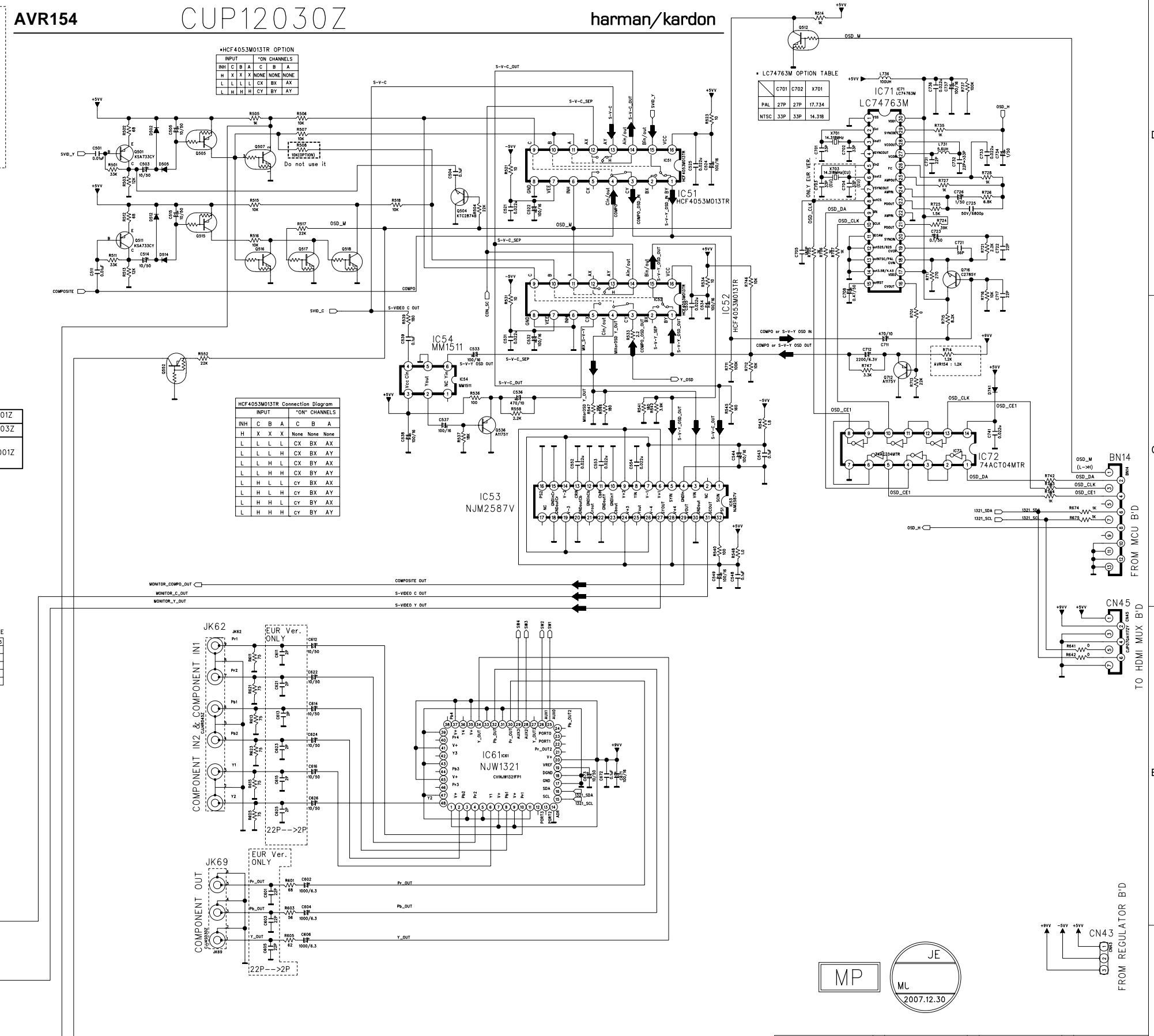
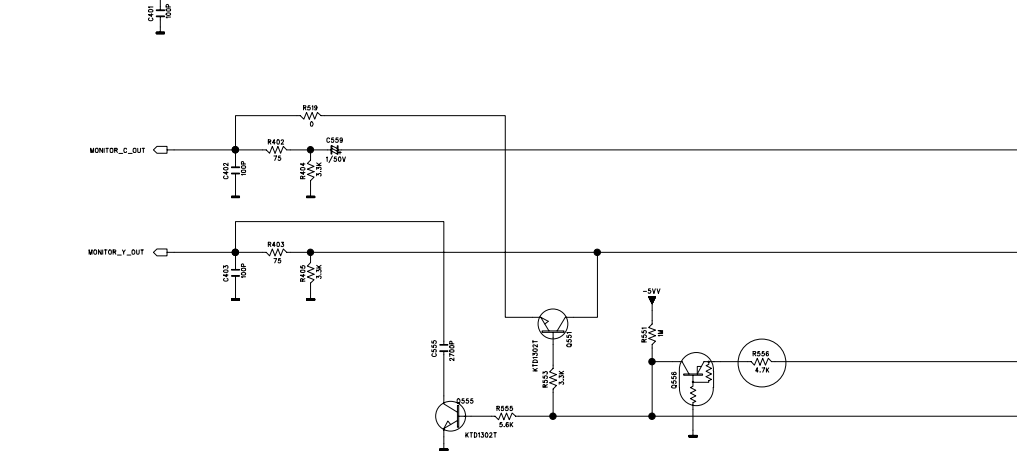
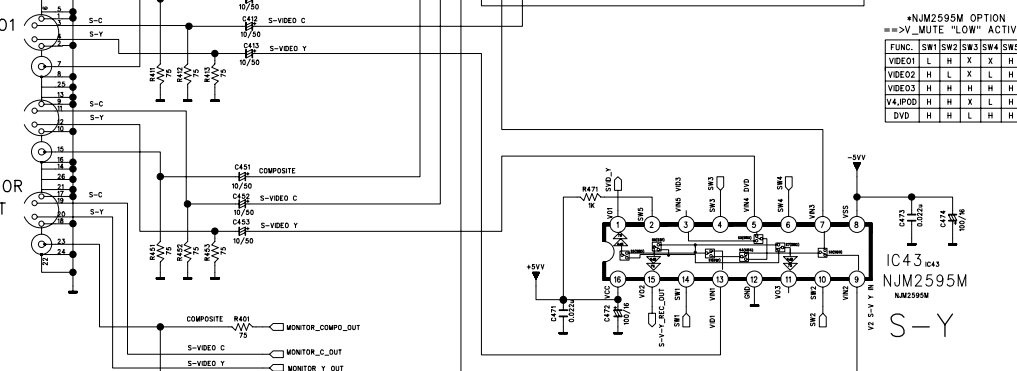
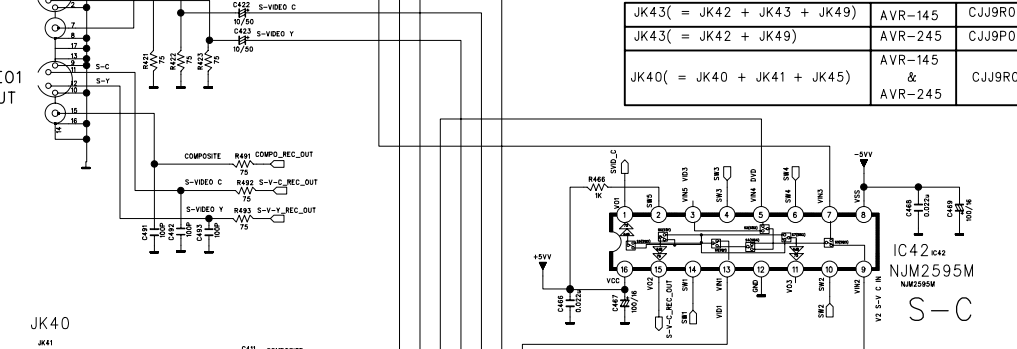
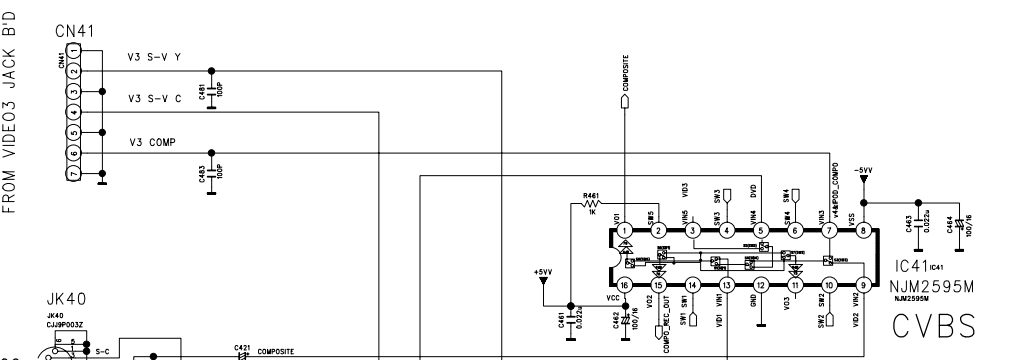
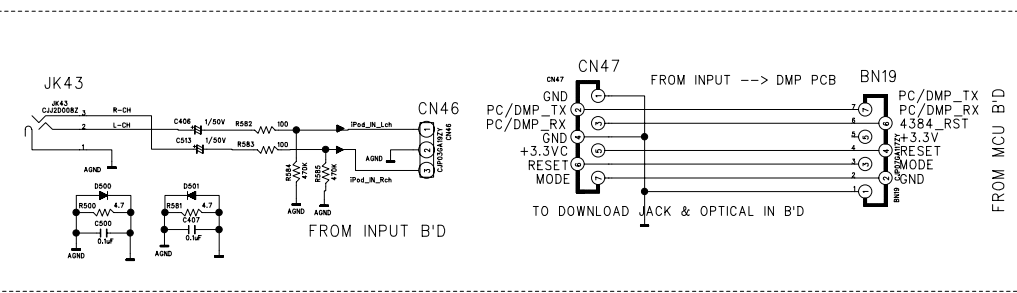

REVISION	2	4	6	
1	3	5	7	
SCHEMATIC DIAGRAM SHEET				
MODEL	AVR154, AVR155/230			5/6
DESIGN	CHECK	APPROVE	DRAWING NO	
S.H.Y	W.Y.Y	K.S.W	2030SCPZ	
07.12.30	07.12.30	07.12.30	(VIDEO)	

AVR154

harman/kardon

CUP12025Z

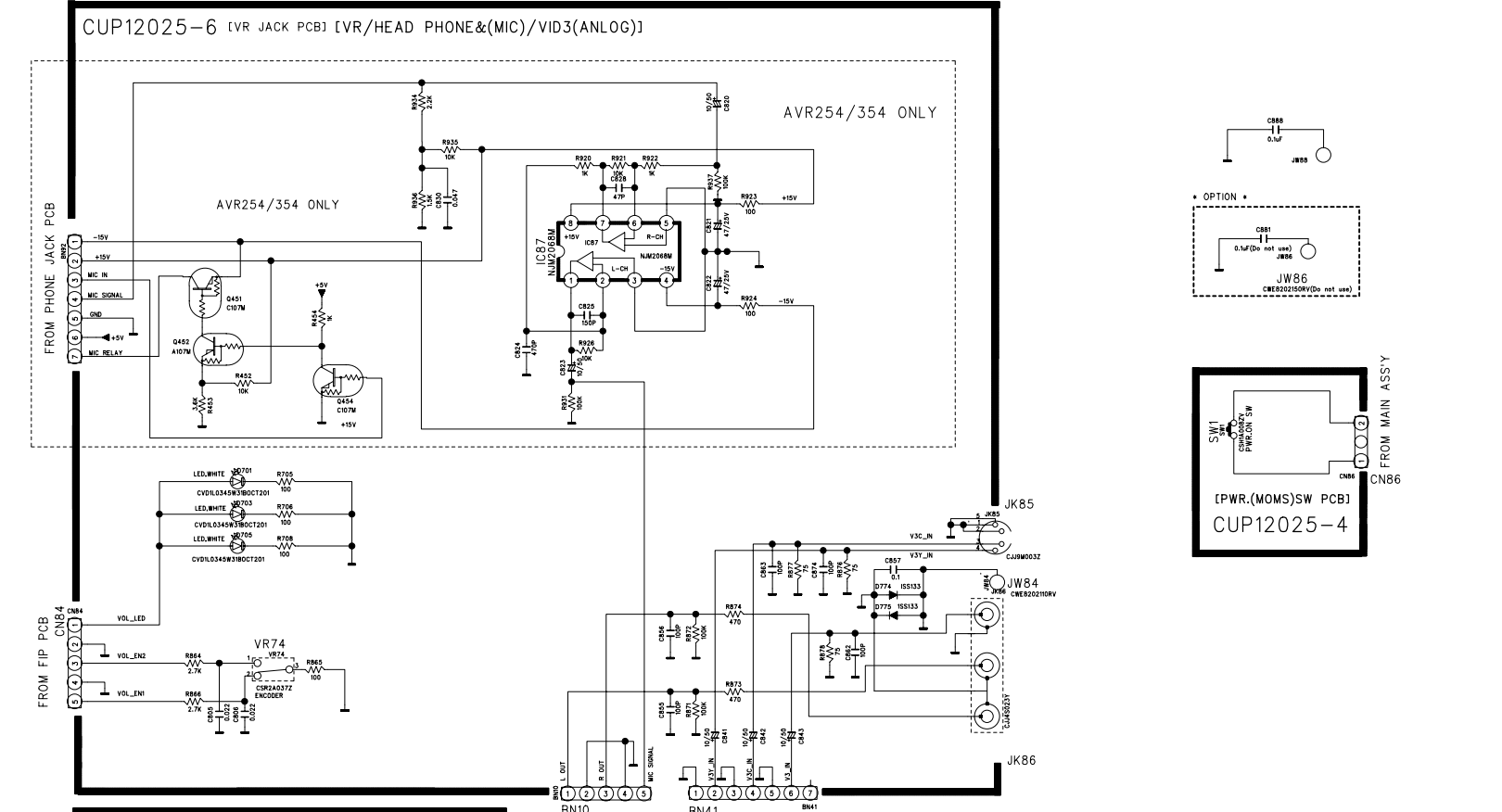
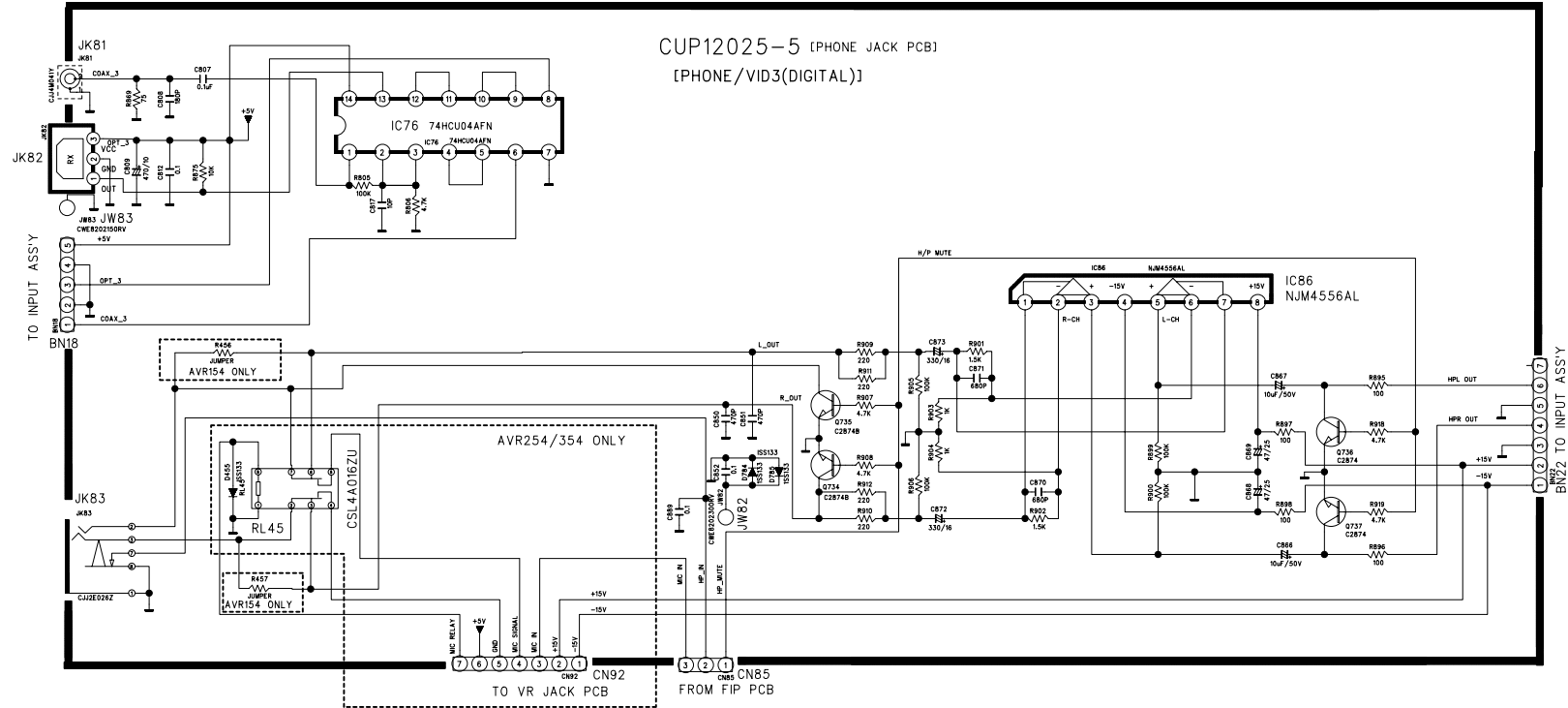
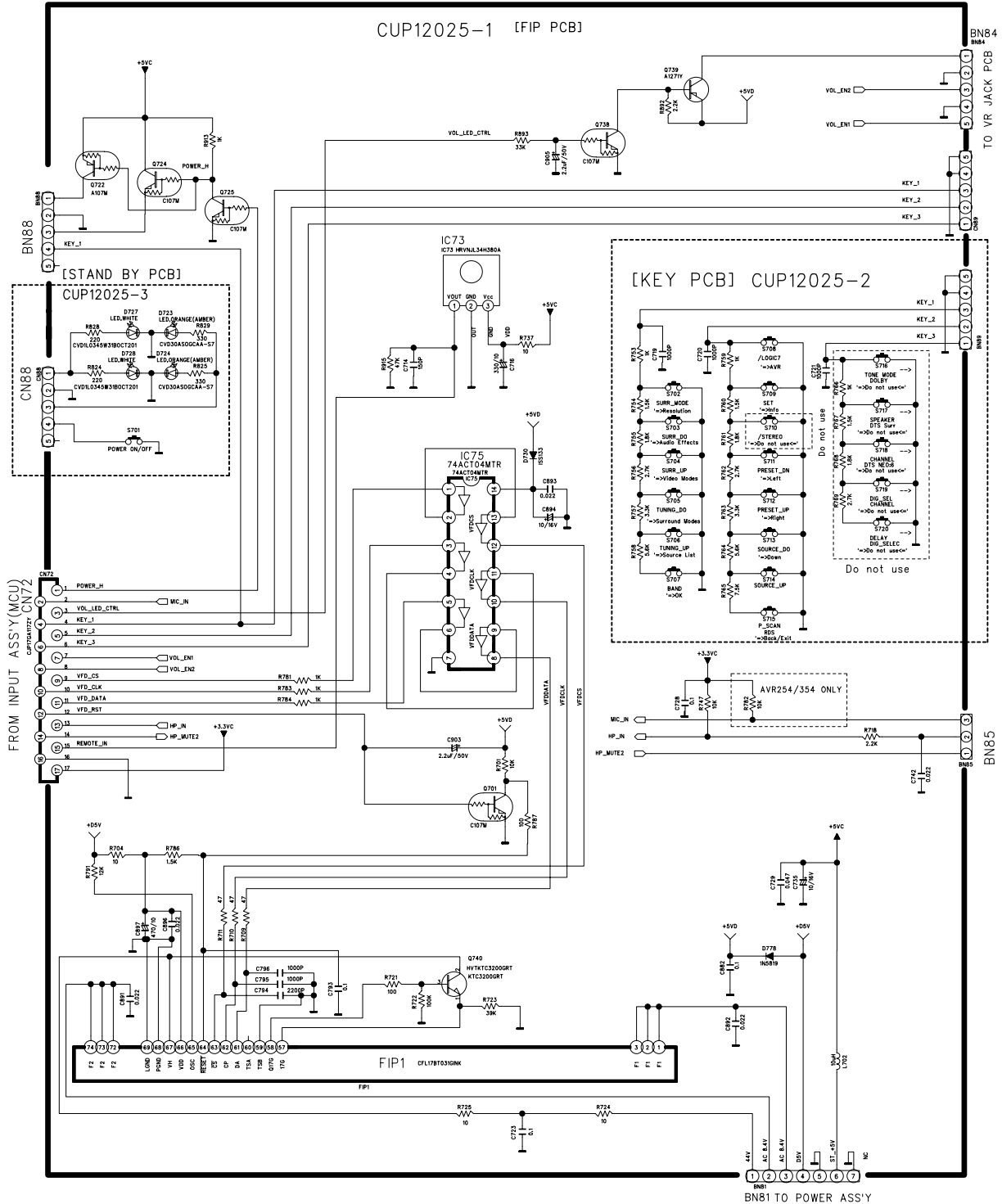

CUP12025-8 [BLACKET JACK PCB FOR CARD CABLE]

CUP12025-9 [BLACKET JACK PCB FOR PHONE JACK]

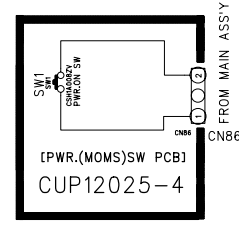

REVISION	2	4	6
1	3	5	7
SCHEMATIC DIAGRAM			
MODEL	AVR154/254/354		
DESIGN	CHECK	APPROVE	DRAWING NO
S.H.YANG	W.Y.YANG	G.S.WEY	2025SCDZ
07.12.07	07.12.07	07.12.07	(FRONT)

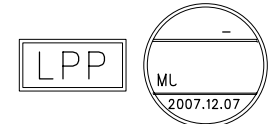

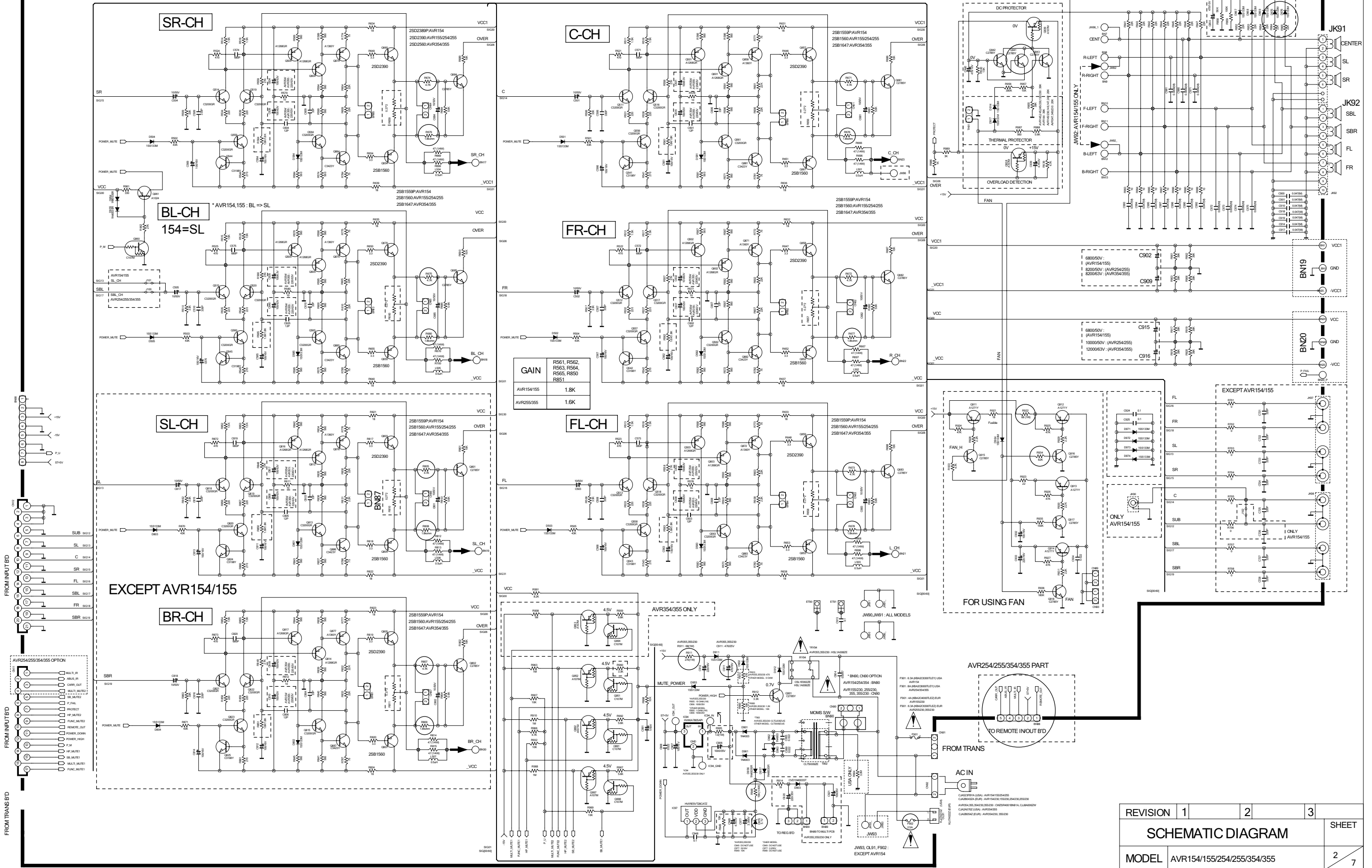

GAIN	R561, R562, R563, R564, R565, R560	1.8K
	AVR154/155	1.8K
	AVR255/355	1.6K

REVISION	1	2	3	SHEET
SCHEMATIC DIAGRAM				
MODEL	AVR154/155/254/255/354/355			
DESIGN	CHECK	APPROVE	DRAWING NO	
C.B.LEE	W.Y.YANG	G.S.WEY	2026SCLZ (MAIN)	
07.08.23				1 / 1

IMPORTANT SAFETY NOTICE:
 IMPORTANT FOR SAFETY WHEN REPLACING ANY OF THESE COMPONENTS
 USE ONLY MANUFACTURER'S SPECIFIED PARTS.
 * THE UNIT OF RESISTANCE IS OHM.
 K=1000 OHM, M=10000 OHM.
 * THE UNIT OF CAPACITANCE IS MICROFARAD (UF)
 P=10⁻¹² F
 * THIS SCHEMATIC DIAGRAM MAY MODIFIED AT ANY TIME WHILE THE
 IMPROVEMENT OF PERFORMANCE



AVR154 WIRING DIAGRAM

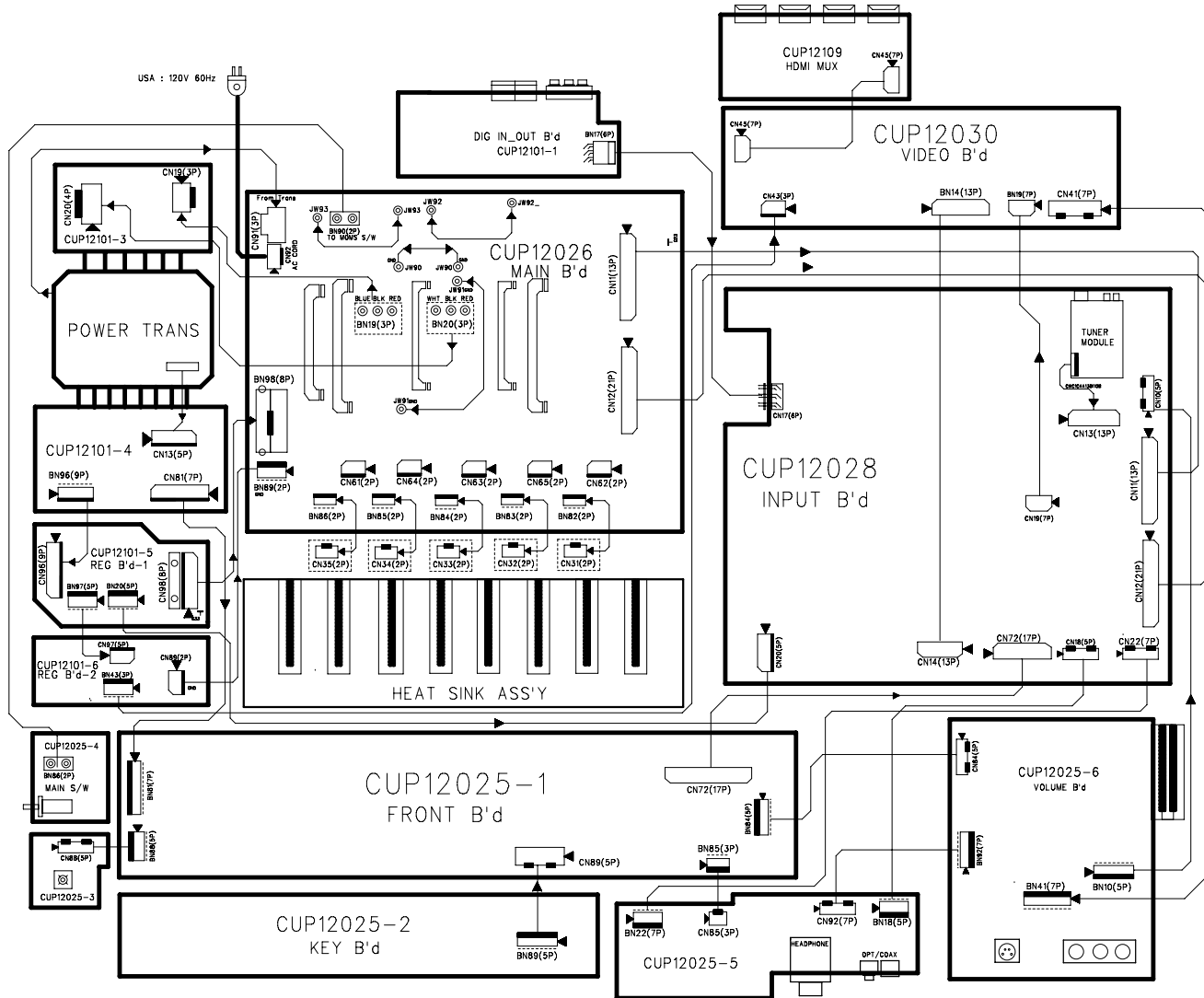

REVISION	2	4	6
1	3	5	7
SCHEMATIC DIAGRAM			
MODEL	AVR154		
DESIGN	CHECK	APPROVE	DRAWING NO
J.T.B	W.Y.Y	K.S.W	WIRING DIAGRAM
08.03.11	08.03.11	08.03.11	1190SCDZ